

Model name	'L'
1185-4	2.0mm
1185A-4	2.5mm
1185B-4	1.8mm

SMD REFLOW PATTERN
(ALL TOLERANCE : ±0.05)

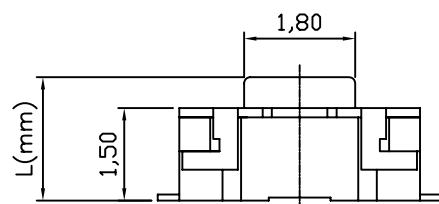

CIRCUIT DIAGRAM

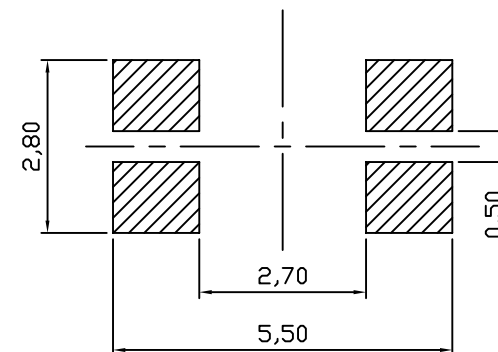
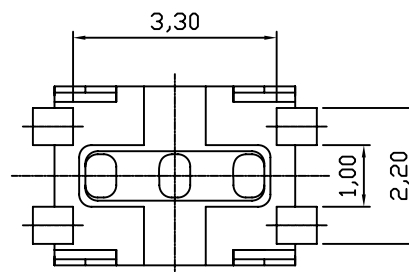
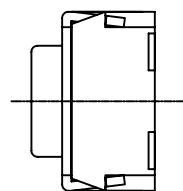
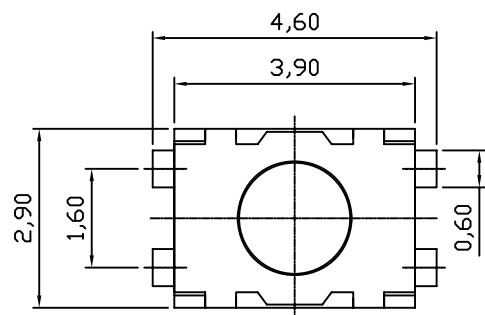
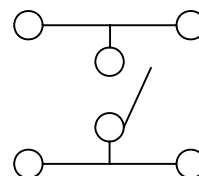

SPECIFICATION

1. RATING : 50mA, DC12V Max.
2. CIRCUIT : 1C-1P.
3. OPERATING FORCE :160,250 ±50gf.
400 ±70gf.
4. CONTACT RESISTANCE : 100mΩMax.
5. TRAVEL : 0.2±0.1mm
6. LIFE : 100,000 Cycles Min
7. TOLERANCE : ± 0.2

NO	PARTS NAME	MATERIAL	SPECIFICATION		Q'TY	FINISH	REFERENCE
		GENERAL TOLERANCE (UNLESS SPECIFIED)	SCALE	UNIT	TITLE	1185-4	DOCUMENT NUMBER
		±0.2	/	METRIC			
			THIRD ANGLE PROJECTION	SIZE A4	SungSan Enterprise, LTD. www.ssetr.co.kr		
		DRAWN BY	CHECKED BY	APPROVED BY			
REV	DESCRIPTION				THIS DRAWING CONTAINS INFORMATION THAT IS PROPRIET TO CREATIVE ELECTRONICS CO.,LTD. AND SHOULD NOT BE USED WITHOUT WRITTEN PERMISSION.		