

MODEL NO	'L'
1157SHNP	2.5mm
1157AHNP	3.1mm

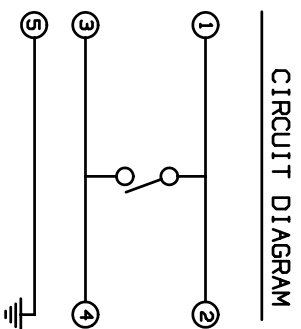

CIRCUIT DIAGRAM

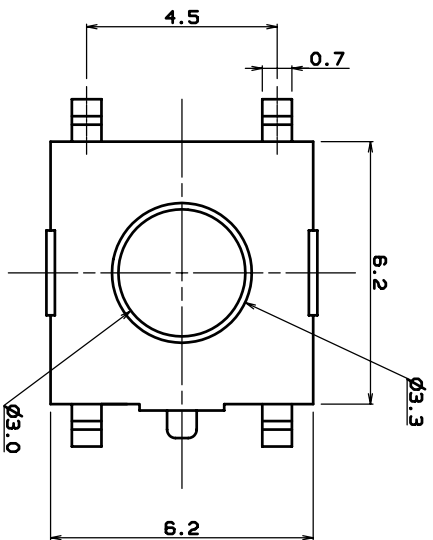
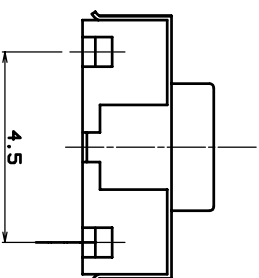
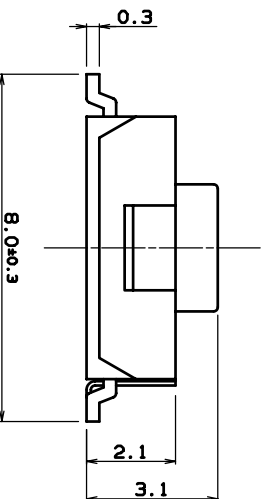

- NOTES**
1. RATING : DC 12V, 50mA MAX
 2. TRAVEL : 0.25 ± 0.1
 3. CONTACT RESISTANCE : 100mΩ MAX
 4. OPERATING FORCE : 160.250 ± 50gf
- * TERMINAL LENGTH : 8mm, 9mm, 10mm

PCB DIMENSION

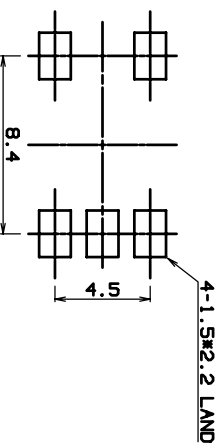

(TERMINAL : 8mm)

NO	PARTS NAME	Q'TY	MATERIAL	REMARK
1	CASE	1	ARLEN	
2	STEM	1	ARLEN	
3	COVER	1	SUS	Sn PLATE
4	CONTACT	1	CS210R	Ag0.5μ CLAD
5	TERMINAL	1	C2680R	Ag PLATE

No.	PART NAME	Q'TY	MATERIAL	SCALE	MODEL	TREAT.	REMARKS
5				1	1157AHNP		
4							
3							
2							
1							

NO.	DATE	NOTE	SIGN	DWG. NO.

ASS'Y DIAGRAM