

MODEL NO	KNOB "L"
1127	1.5mm
1127A	4.3mm

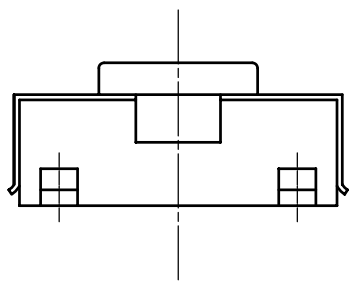

PCB DIMENSION

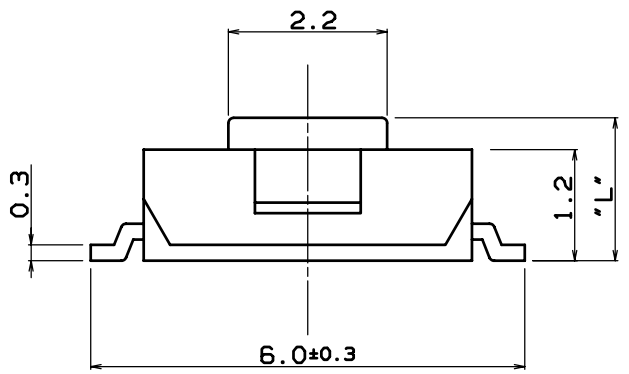
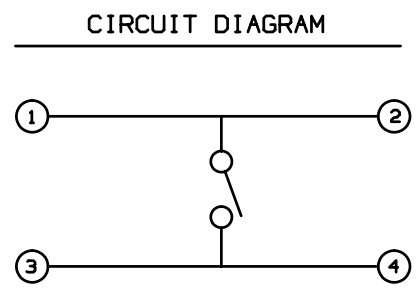
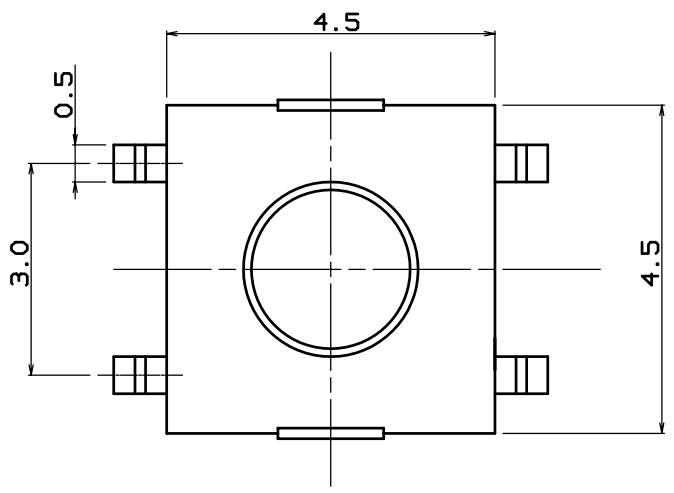
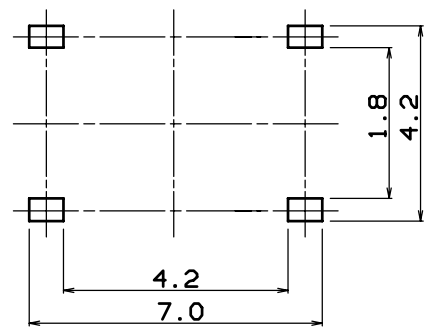

NOTES

1. RATING : DC 12V,50mA MAX
2. TRAVEL : 0.25 ±0.1
3. CONTACT RESISTANCE : 100mΩ MAX
4. OPERATING FORCE :

No.	PART NAME	Q'TY	MATERIAL	SCALE	MODEL	TREAT.	REMARKS
5			3RD ANGLE PROJECTION	UNIT	1127		
4			APPROVED	m/m		DWG. NAME	
3				CHECKED	ASS'Y DIAGRAM		
2				DESIGNED	DWG. NO.		
1							
NO.	DATE	NOTE	SIGN				