

P.C.B DIMENSION

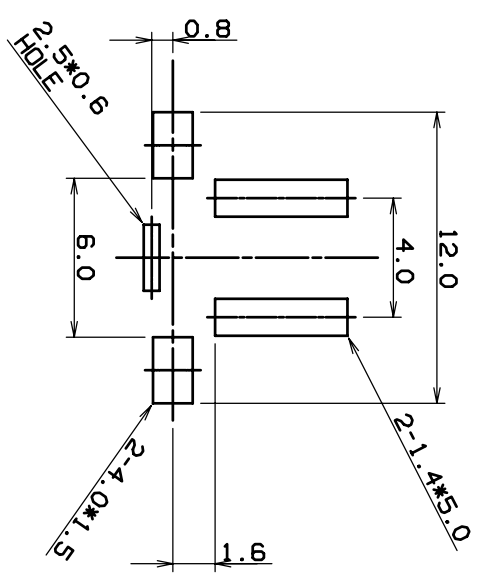

KNOB TYPE	*L* (mm)
BLANK	3.15
A	3.85
B	5.85
C	8.35
D	6.85
E	6.15
F	11.35
G	12.35
H	8.55
I	15.85
J	15.15

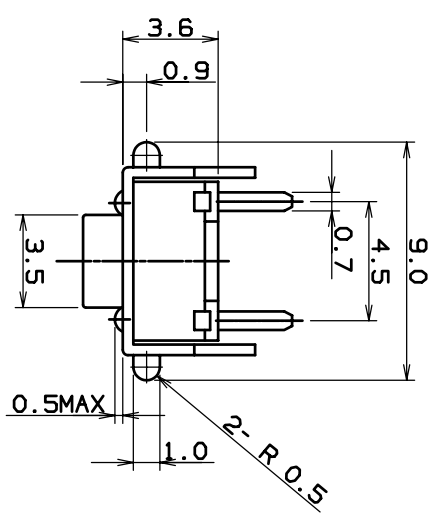
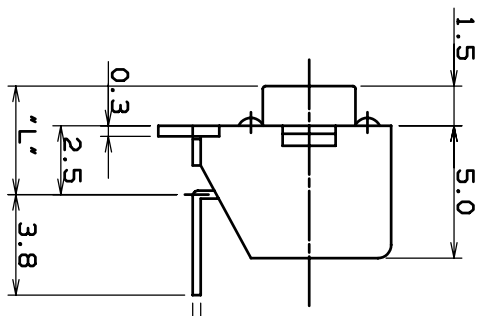
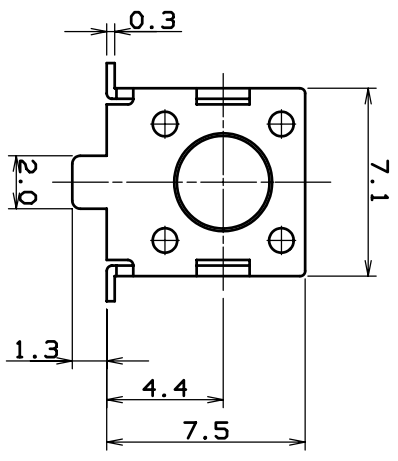

- NOTE
1. OPERATING FORCE : 100,130,160±30gf
250 ± 50gf
 2. TRAVEL : 0.25 +0.2/-0.1 mm
 3. CONTACT RESISTANCE : 100mΩ Max
 4. GENERAL TOLERANCE : ±0.3
 5. RATING : DC 12V 50mA

CIRCUIT DIAGRAM



No.	PART NAME	Q'TY	MATERIAL	SCALE	MODEL	TREAT.	REMARKS
△					1102US		
△							
△							
△							
△							
△							
△							
△							
△							
NO.	DATE	NOTE	SIGN		DWG. NAME		
					ASS'Y DIAGRAM		
					DWG. NO.		