

1101VS	W/O EMBOSSING
1101VSE	WITH EMBOSSING

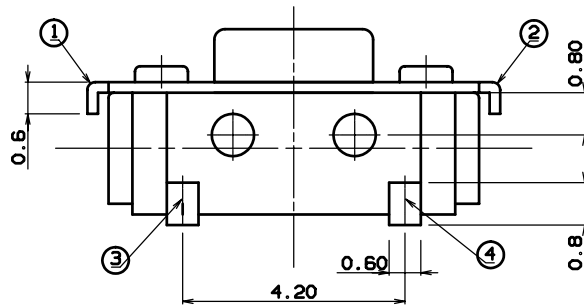

CIRCUIT DIAGRAM

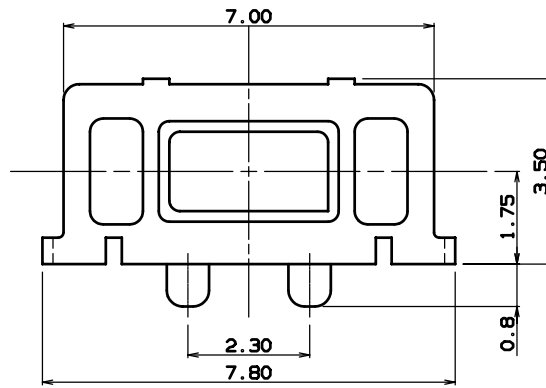
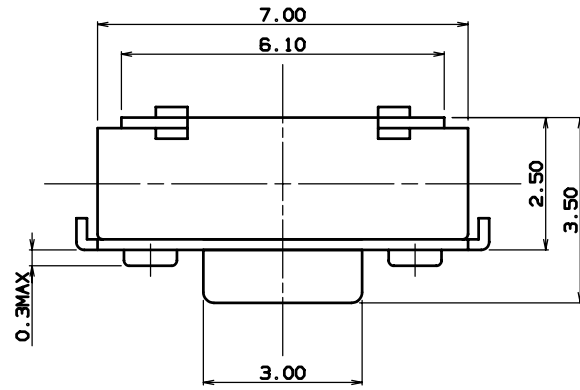
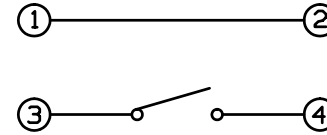

P.C.B LAND PATTERN

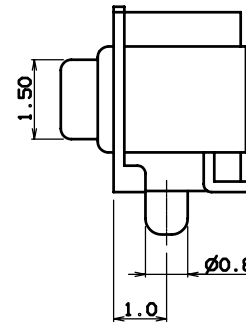
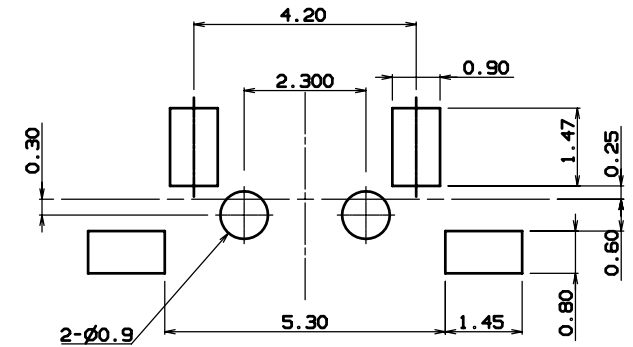

NOTE

- 1.RATING : DC12V 50mA
- 2.TRAVEL : 0.25 ±0.1mm
- 3.OPERATING FORCE : 180gf ±50
- 4.CONTACT RESISTANCE : 100mΩ Max

No.	PART NAME	Q'TY	MATERIAL	SIZE	TREAT.	REMARKS
③			3RD ANGLE PROJECTION	UNIT	SCALE	MODEL
④			APPROVED	m/m	1	1101VS
②			CHECKED	DESIGNED		DWG. NAME
①						ASS'Y DIAGRAM
						DWG. NO.
NO.	DATE	NOTE	SIGN			