

NO	PART NAME	Q'TY	MATERIAL	REMARK
1	COVER	1	PET FILM	
2	STEM	1	NY66 G30	IVORY
3	CASE	1	NY66 G30	BLACK
4	TERMINAL	1	C2680R-EH	A9 PLATE
5	CONTACT	1	CS210R-EH	A9 0.5 $\mu$
6	BRACKET	1	NY66 G30	BLACK

- NOTE
1. RATING : DC 12V, 50mA
  2. CONTACT RESISTANCE: 100m $\Omega$  Max
  3. OPERATING FORCE: 160 $\pm$ 50gf
  4. TRAVEL : 0.3 $\pm$ 0.15 mm
  5. GENERAL TOLERANCE:  $\pm$ 0.3

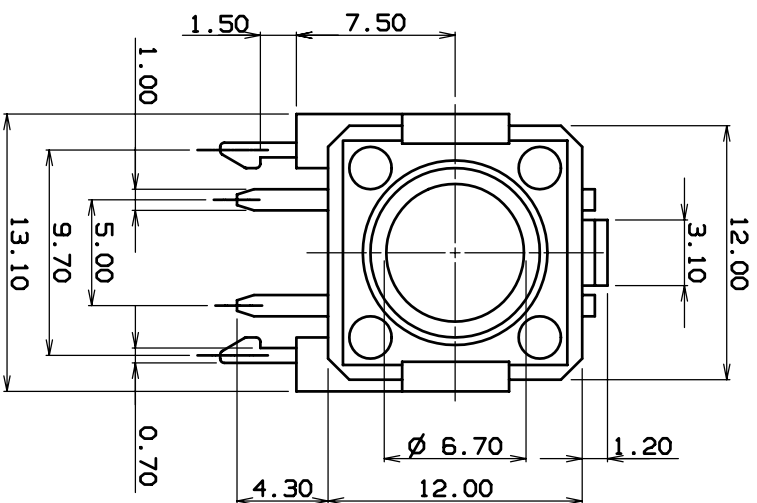

CIRCUIT DIAGRAM

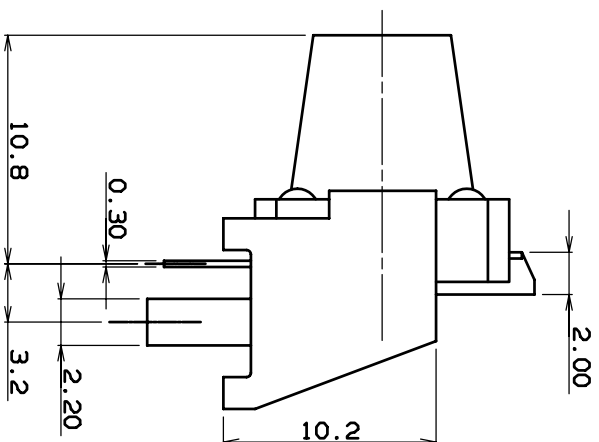
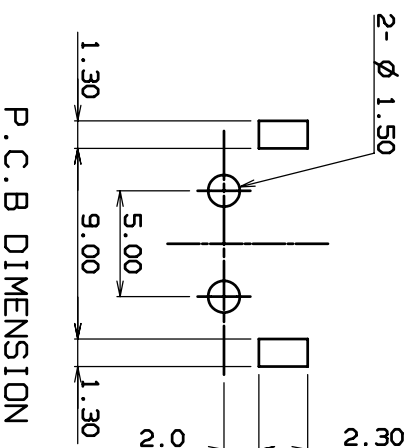

P.C.B DIMENSION

NO.	PART NAME	Q'TY	MATERIAL	SCALE	MODEL	TREAT.	REMARKS
5/				1	1103VD		
4/							
3/							
2/							
1/							
NO.	DATE	NOTE	SIGN		DWG. NAME		
					ASS'Y DIAGRAM		
					DWG. NO.		