

TERMINAL NO ①

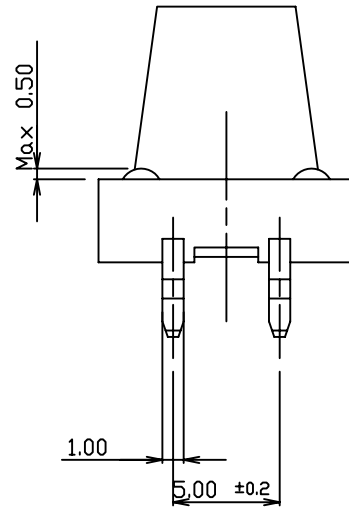

CIRCUIT DIAGRAM

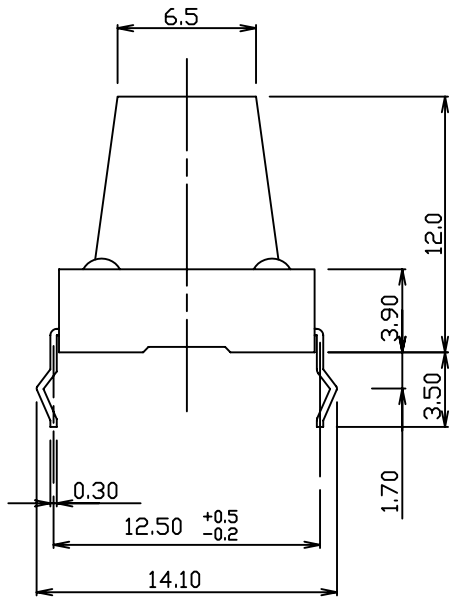
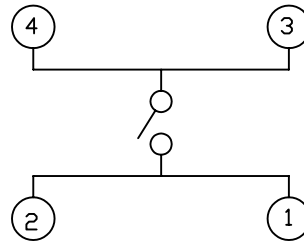

P.C.B DIMENSION

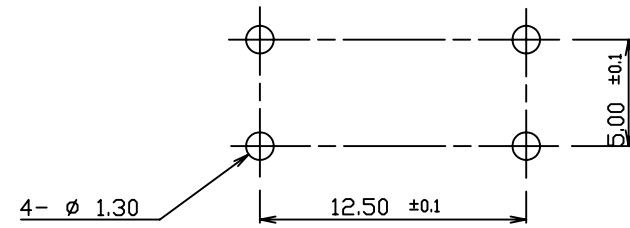

NOTE

- 1.RATING :DC 12V,50mA
- 2.CONTACT RESISTANCE:100mΩ Max
- 3.OPERATING FORCE:160±50gf
- 4.TRAVEL :0.3±0.15 mm
- 5.GENERAL TOLERANCE:±0.3

NO	PART NAME	Q'TY	MATERIAL	REMARK
1	COVER	1	PET FILM	
2	STEM	1	PBT G30	IVORY
3	CASE	1	PBT G30	BLACK
4	TERMINAL	1	C2680R-EH	Ag0.5μ
5	CONTACT	1	C5210R-EH	Ag 0.5μ

No.	PART NAME	Q'TY	MATERIAL	SCALE	MODEL	TREAT.	REMARKS
5				UNIT	1103D		
4				m/m			
3				APPROVED	DWG.NAME		
2				CHECKED	ASS'Y DIAGRAM		
1				DESIGNED	DWG.NO.		
NO.	DATE	NOTE	SIGN	.	.	.	