

CIRCUIT DIAGRAM

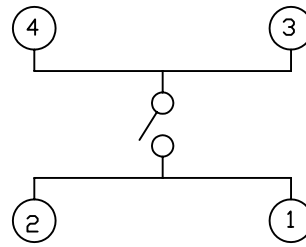

NO	PART NAME	Q'TY	MATERIAL	REMARK
1	COVER	1	PET FILM	
2	STEM	1	ACETAL	BLACK
3	CASE	1	PBT G30	BLACK
4	TERMINAL	1	C2680R-EH	Ag 1 μ
5	CONTACT	1	C5210R-EH	Ag 0.5 μ

P.C.B DIMENSION

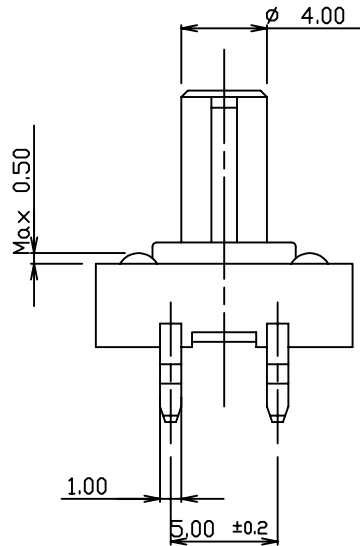
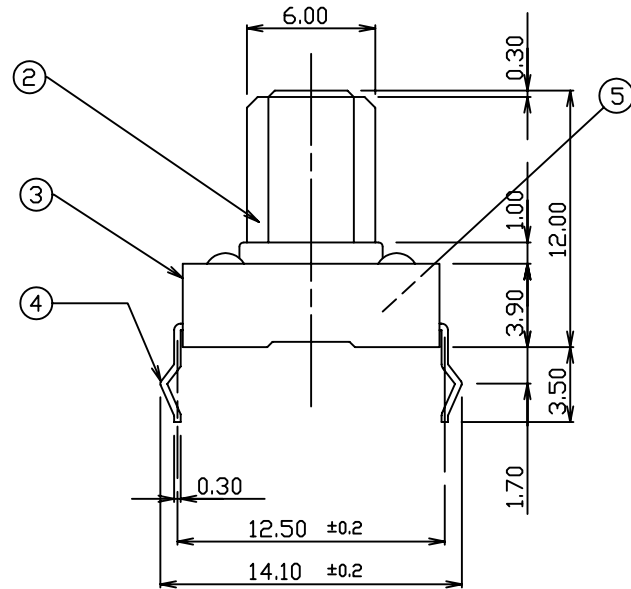
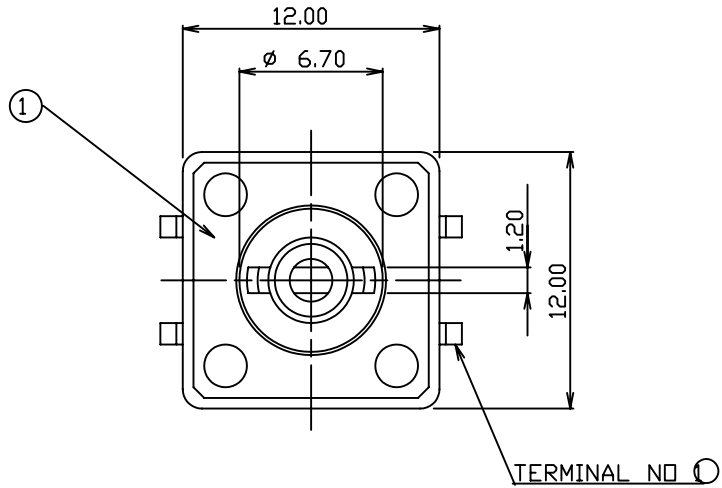
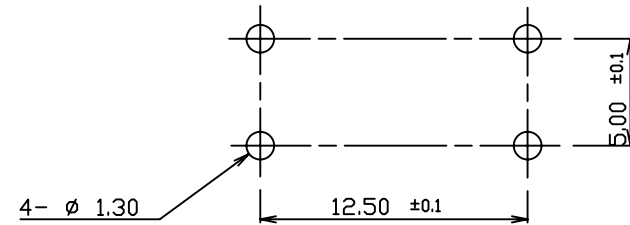

NOTE

- 1.RATING :DC 12V,50mA
- 2.CONTACT RESISTANCE:100m Ω Max
- 3.OPERATING FORCE:160 \pm 50gf
- 4.TRAVEL :0.3 \pm 0.15 mm
- 5.GENERAL TOLERANCE: \pm 0.3

No.	PART NAME	Q'TY	MATERIAL	SIZE	TREAT.	REMARKS
			UNIT	SCALE	MODEL	
			m/m	1	1103A	
			APPROVED	CHECKED	DWG.NAME	
				DESIGNED	ASS'Y DIAGRAM	
					DWG.NO.	
NO.	DATE	NOTE	SIGN			