

1. GENERAL

1. 1 Application : This specification is applied to MULTI WAY SWITCH for electronic equipment.
1. 2 Operating Temperature Range : -25 ~ 70
1. 3 Storage Temperature Range : -40 ~ 85 . However, 96 hours maximum for continuous storage over a range -20 ~ -40 and a range 70 ~ 85
1. 4 Test Condition : The standard test conditions shall be 5 ~ 35 in temperature, 45 ~ 85% RH and 860 ~ 1060mbar in atmospheric pressure.
Should any doubt arise in judgment, tests shall be conducted at 20 ±2 , 65 ±5% RH and 860 ~ 1060mbar.

2. RATED VOLTAGE AND CURRENT

12V DC, 50mA

3. ELECTRICAL PERFORMANCE

	PROPERTY	TEST CONDITION	PERFORMANCE
3. 1	Contact Resistance	1) Center Push Measurements shall be given at 5V DC, 1mA and with 600gf static load.	100m Max
		2) 4-Directional Measurements shall be given at 5V DC, 1mA and with 400gf rotation torque.	
3. 2	Insulation Resistance	A voltage of 100V DC shall be applied for 1 minute after which measurements shall be made 1) Between Terminals	100M Min
3. 3	Dielectric Strength	2) Between Terminal and Stem A voltage of 100V AC shall be applied for 1 minute or 120V AC shall be applied for 1 second. Cut off current 2mA 1) Between Terminals 2) Between Terminal and Stem	Without arcing or breakdown. etc.

4. MECHANICAL PERFORMANCE

	PROPERTY	TEST CONDITION	PERFORMANCE
4. 1	Operating Force	1) Center Push Operating force shall be applied to the stem in axially, and then the maximum force until reaching the end shall be measured.	240±50gf
		2) 4-Directional Operating force shall be applied to the stem, and then the maximum force until reaching the end shall be measured.	160±50gf

DATE		DESIGNED	CHECKED	APPROVED	PAGE
S/W TYPE	MULTI WAY S/W				1/4
MODEL NO.	BT1600				
DOCUMENT NO.		/ /	/ /	/ /	

4. MECHANICAL PERFORMANCE

	PROPERTY	TEST CONDITION	PERFORMANCE
4. 2	Operating Travel	1) Center Push Operating force shall be applied to the stem in axially, and then the amount of movement until reaching the end shall be measured.	0.15 ±0. 1mm
		2) 4-Directional Operating force shall be applied to the stem in perpendicularly, and then the amount of angle movement until reaching the end shall be measured.	0.25 ±0. 1mm
4. 3	Operational Strength	1) Pushing and Pulling Directions A static load of 1kgf shall be applied to the stem in the pulling and pushing directions for 10 seconds.	The following specifications must be satisfied. Contact Resistance : Item 3. 1 Insulation Resistance : Item 3. 2 Dielectric Strength : Item 3. 3 Operating Force : Item 4. 1
		2) Stem Operating Direction A static load of 1kgf shall be applied to the stem for 10 seconds with following method.	
		3) Rotating Direction A static rotating torque of 1kgf shall be applied to the stem in the rotating directions for 10 seconds.	
4. 4	Terminal Strength	With the switch fixed a static load of 100gf shall be applied at the top of terminal lugs in any one direction for 3 seconds.	Without damage or obvious looseness of terminals. However, bends having no adverse effect upon electrical performance are allowable.

5. WEATHER PROOF

	PROPERTY	TEST CONDITION	PERFORMANCE
5. 1	Endurance Proof (with load)	The switch shall be operated with 5V DC, 1mA (resistance load) the test conditions are as follows. 1) Center Push Operating Times : 50,000 times Operating Force : 500gf Operating Speed : 60 ~ 100 times/minute 2) 4-Directional Operating Times : For each 50,000 times (4 directions) Operating Force : 400gf (at the top of stem) Operating Speed : 15 ~ 20 times/minute	The following specifications must be satisfied. Contact resistance : 500m Max Insulation Resistance:10M Min Dielectric Strength : Item 3. 3 Operating Force : Within ±30% of the initial specified value.

DATE		DESIGNED	CHECKED	APPROVED	PAGE
S/W TYPE	MULTI WAY S/W				2/4
MODEL NO.	BT1600				
DOCUMENT NO.		/ /	/ /	/ /	

5. WEATHER PROOF

	PROPERTY	TEST CONDITION	PERFORMANCE
5. 2	Dry Heat Proof	The switch shall be stored at a temperature of 85 ± 2 for 96 hours. Then the switch shall be maintained at standard atmospheric conditions for 1 hour, after which measurements shall be made within 1 hour.	<p>The following specifications must be satisfied.</p> <p>Contact Resistance : 500m Max</p> <p>Insulation Resistance : 10M Min</p> <p>Dielectric Strength : Item 3. 3</p> <p>Operating Force : Within $\pm 30\%$ of the initial specified value.</p>
5. 3	Cold Proof	The switch shall be stored at a temperature of -40 ± 3 for 96 hours. Then the switch shall be maintained at standard atmospheric conditions for 1 hour, after which measurements shall be made within 1 hour.	
5. 4	Damp Heat Proof	The switch shall be stored at a temperature of 40 ± 2 and a relative humidity of 90 ~ 95% for 96 hours. Then the switch shall be maintained at standard atmospheric conditions for 1 hour, after which measurements shall be made within 1 hour. Moisture which has condensed on the switch is to be removed before initiation of the test.	
5. 5	Change of Temperature	The switch shall be subjected to 5 successive change of temperature cycles, each conditions are as follows. Then the switch shall be maintained at standard atmospheric conditions for 1 hour, after which within 1 hour.	
5. 6	Vibration	The switch shall be soldered on the P.W.B (single sided copper clad phenolic laminatet=1. 6) and attach this to the testing table. Then the test shall be given within the following conditions. Frequency Range : 10 ~ 55 Hz Amplitude (total excursion) : 1. 5mm Frequency sweep : 10 ~ 55 ~ 10 Hz/min. Frequency method : The logarithm curve or straight approximation line Directions of Vibration : X, Y and Z axes Duration : 2 hours per axis (a total of 6 hours)	

DATE		DESIGNED	CHECKED	APPROVED	PAGE
S/W TYPE	MULTI WAY S/W				3/4
MODEL NO.	BT1600				
DOCUMENT NO.		/ /	/ /	/ /	

6. SOLDERING CONDITIONS

6. 1 Reflow soldering conditions

6. 2 Preheat : temperature on the copper foil surface should reach 180 , 2±0.3 minutes after the P.W.P entered into the soldering equipment.

6. 3 Soldering heat : Temperature on ther copper foil surface should reach the peak temperature of 240 within 20 seconds after the P.W.B entered into soldering heat zone.

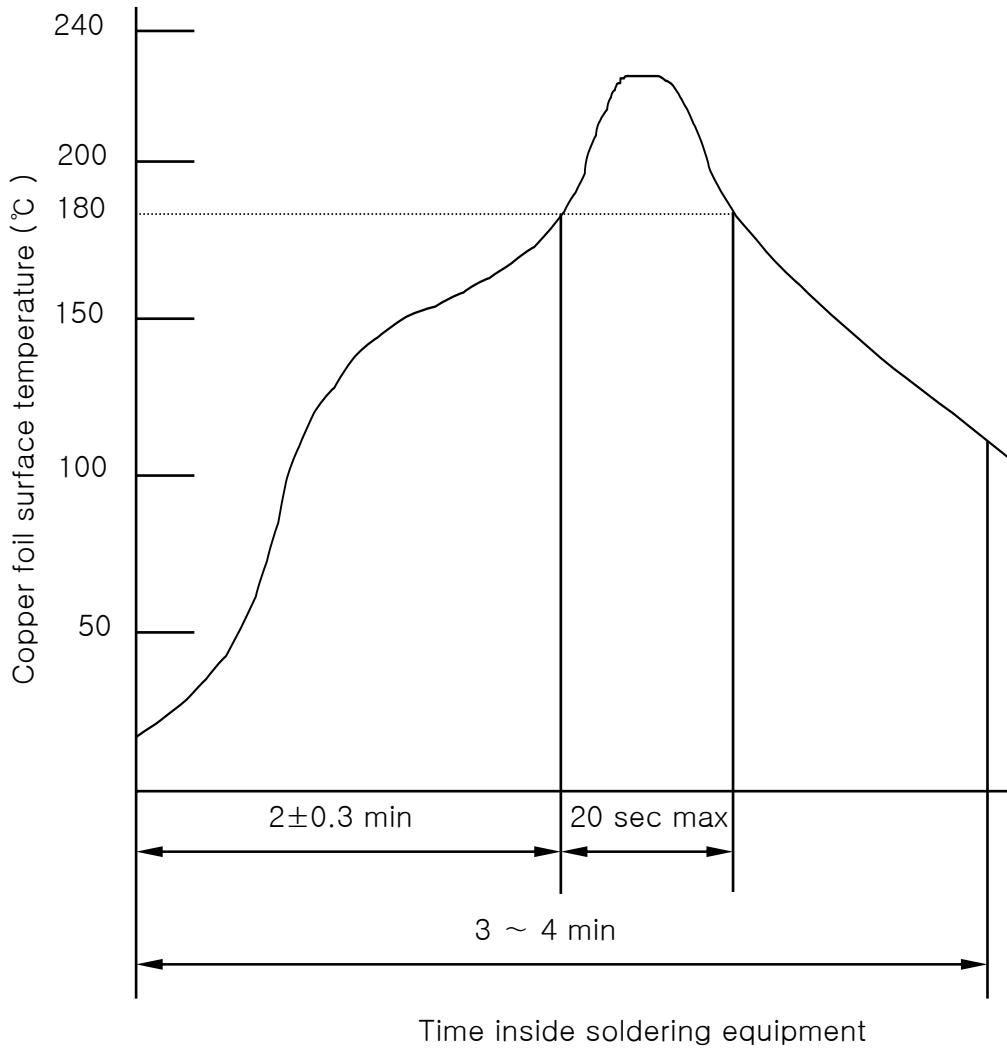

Temperature Profile

7. PRECAUTIONS

Do not attempt to wash the switches. They are not of air tight and water-proof design.

DATE		DESIGNED	CHECKED	APPROVED	PAGE
S/W TYPE	MULTI WAY S/W				4/4
MODEL NO.	BT1600				
DOCUMENT NO.		/ /	/ /	/ /	

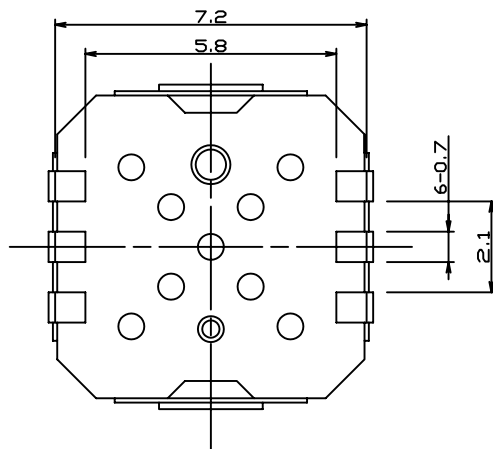
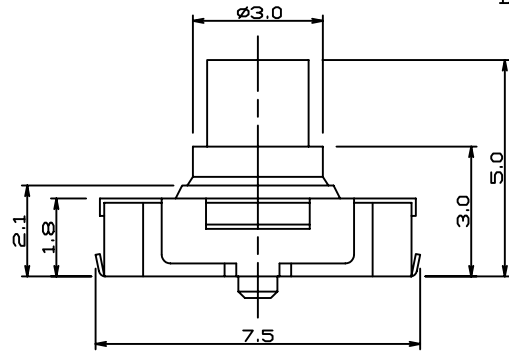
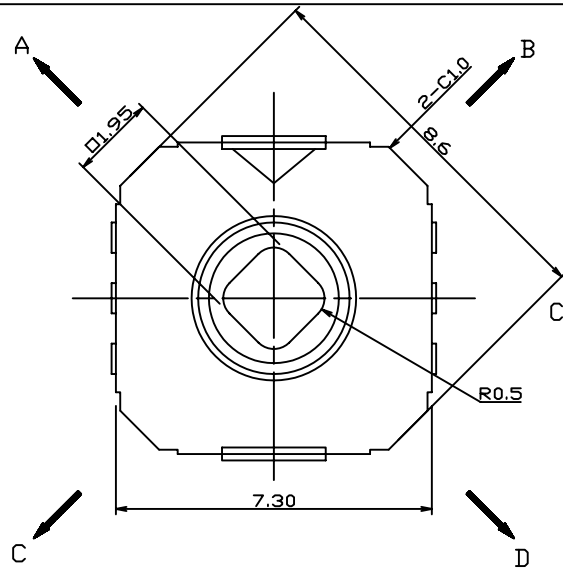

CIRCUIT DIAGRAM

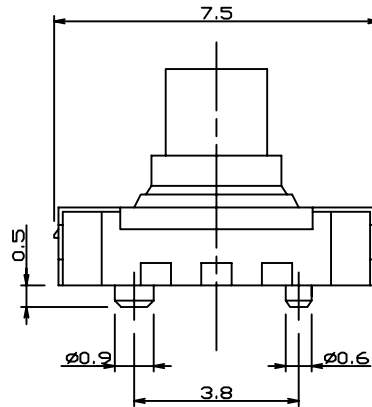
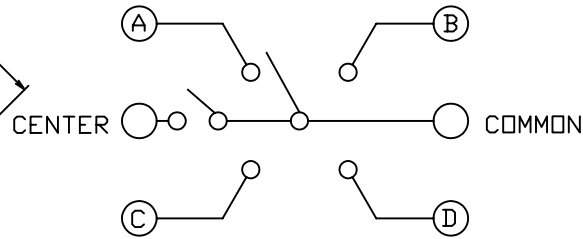

P.C.B DIMENSION

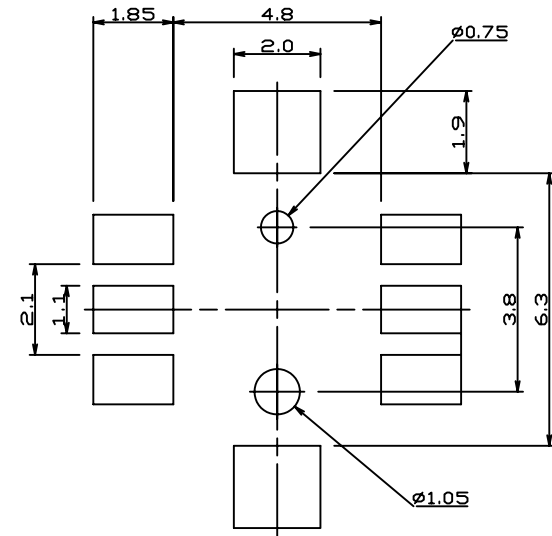

NOTE

1.OPERATING FORCE

- 1) 4-DIRECTIONAL : 160 ±50gf
- 2) CENTER : 240 ±50gf

2.TRAVEL

- 1) 4-DIRECTIONAL : 0.25 ± 0.1mm
- 2) CENTER : 0.15 ± 0.1mm

3.RATINGS : 50mA 12V DC MAX

4.INITIAL CONTACT RESISTANCE : 500mΩ MAX

5.LIFE TIME : 200,000 SYCLE

6.GENERAL TOLERANCE : ± 0.2

No.	PART NAME	Q'TY	MATERIAL	SIZE	TREAT.	REMARKS
3			3RD ANGLE PROJECTION	UNIT m/m	SCALE 1	MODEL 1501
3			APPROVED	CHECKED	DESIGNED	DWG.NAME ASS'Y DIAGRAM
3						DWG.NO.
ND.	DATE	NOTE	SIGN			