

REV.	DESCRIPTION	DRAWN	CHECKED	APPROVED
A	NEW RELEASE	LJH 05/24/05'		

NOTES:

- ELECTRICAL CHARACTERISTICS:
 - CONTACT RESISTANCE: 20mΩ Max.
 - DIELECTRIC WITHSTANDING VOLTAGE: 500V AC(rms) FOR 1 MINUTE.
 - INSULATION RESISTANCE: 1000MΩ Min.
- ENVIRONMENT CHARACTERISTICS:
 - TEMPERATURE: -40°C~+105°C.
- PART NUMBER: DS1001-03
- PRODUCT NUMBER CODE:

DS1001-03 - X X X X

- Clip plating
 - Tin 150u"
 - Tin 200u"
 - G/F
 - Gold 3u"
 - Gold 10u"
 - Gold 15u"
- Pin plating
 - Tin 150u"
 - Tin 200u"
 - G/F
 - Gold 3u"
 - Gold 10u"
 - Gold 15u"
- Width
 - N: 10.16mm
 - W: 15.24mm
 - D: 19.05mm
- No. of contacts
 - 24 28 42 48 52 56 64
- Series No.
 - DS1001-03

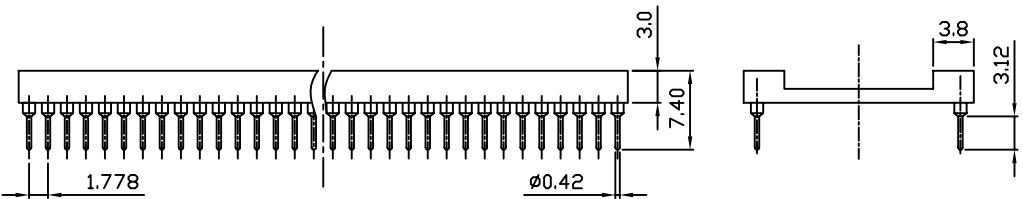
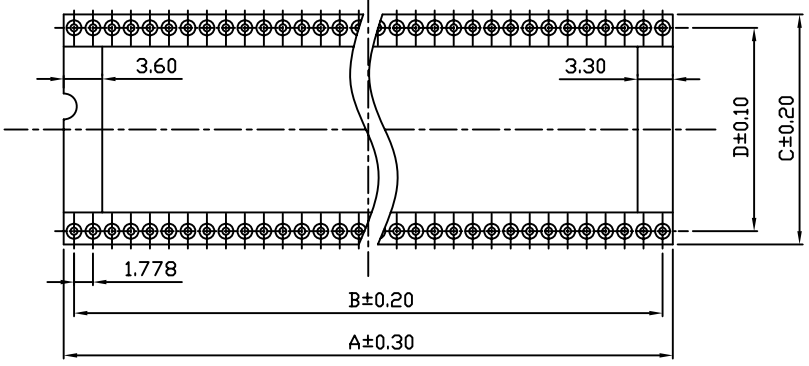

Position	Dimension			
	A	B	C	D
24	21.46	19.56	12.65	10.16
28	25.01	23.11	12.65	10.16
42	37.46	35.56	17.73	15.24
48	42.79	40.89	17.73	15.24
52	46.35	44.45	17.73	15.24
56	49.91	48.01	17.73	15.24
64	57.04	55.12	21.54	19.05

GENERAL TOLERANCE		ANGLE TOLERANCE	
X.	±0.60	X.	±5°
.X	±0.38	.X	±3°
.XX	±0.25	.XX	±2°

PROJECTION	TITLE
UNITS	DIP IC SOCKET PITCH 1.778mm
SHEET SIZE	SERIES DS1001-03 SERIES

2	CONTACT	COPPER ALLOY	GOLD PLATED	DRAWING TYPE	CUSTOMER
1	HOUSING	THERMOPLASTIC	UL 94 V-0	SCALE	1:1 SHEET 1 OF 1
ITEM	PART NAME	PART NO.	MATERILAS	FINISHED	DRAWING NO. C-DS1001-03-XXXX

晨翔电子有限公司
CONNFLY CONNFLY ELECTRONIC CO. LTD

REV.	DESCRIPTION	DRAWN	CHECKED	APPROVED
A	NEW RELEASE	LJH 09/29/05'		

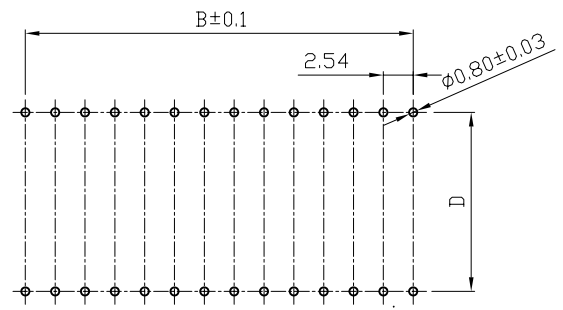
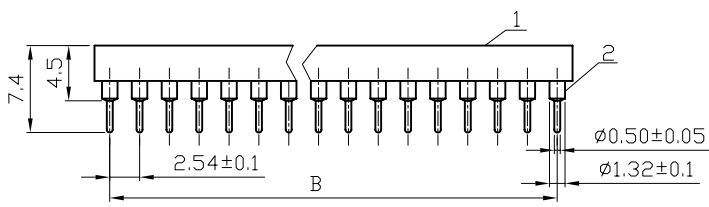
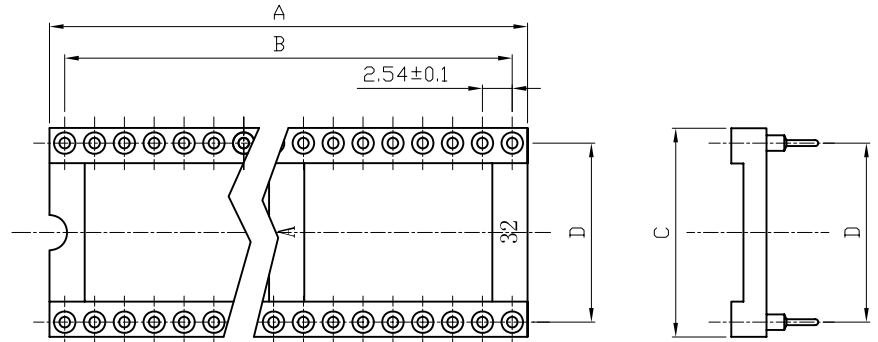

NOTES:

- ELECTRICAL CHARACTERISTICS:
 - CONTACT RESISTANCE: 20mΩ Max.
 - DIELECTRIC WITHSTANDING VOLTAGE: 500V AC FOR 1 MINUTE.
 - INSULATION RESISTANCE: 1000MΩ Min.
- ENVIRONMENT CHARACTERISTICS:
 - TEMPERATURE: -40°C~+105°C.
- PART NUMBER: DS1001-01
- PRODUCT NUMBER CODE:
DS1001-01 - X X X X X X X

Position	Dimension			
	A±0.5	B±0.3	C	D±0.2
06	7.62	5.08	10.16	7.62
08	10.16	7.62	10.16	7.62
14	17.78	15.24	10.16	7.62
16	20.32	17.78	10.16	7.62
18	22.86	20.32	10.16	7.62
20	25.40	22.86	10.16	7.62
24	30.48	27.94	10.16	7.62
28	35.56	33.02	10.16	7.62
24	30.48	27.94	17.78	15.24
28	35.56	33.02	17.78	15.24
32	40.64	38.10	17.78	15.24
40	50.80	48.26	17.78	15.24

- CENTRAL SUPPORT
- S: W/ CENTRAL SUPPORT
- X: W/o CENTRAL SUPPORT
- CLIP PLATING
- F6: Full 3u" gold
- T1: Full Tin
- 7: Full 30u" gold
- HOUSING MATERIAL
- S: PBT
- WIDTH
- N: 7.62mm(06-24P)
- W: 15.24mm(24-40P)
- PIN PLATING
- T1: Full Tin
- 8: Full GOLD FLASH
- CLIP TYPE
- B: 4 FINGERS
- No.OF CONTACTS
- 06 08 12 14 16 18
- 20 24 28 32 40
- SERIES No.
- DS1001-01

RECOMMEND PCB LAYOUT(TOLERANCE=±0.05)

GENERAL TOLERANCE		ANGLE TOLERANCE	
X.	±0.60	X.	±5'
.X	±0.38	.X	±3'
.XX	±0.25	.XX	±2'

PROJECTION		TITLE	DIP IC SOCKET PITCH2.54mm(0.100")
UNITS	mm	SHEET SIZE	A4
SHEET SIZE	A4	SERIES	DS1001-01 SERIES

2	CONTACT		COPPER ALLOY	GOLD PLATED	DRAWING TYPE	CUSTOMER		
1	HOUSING		THERMOPLASTIC	UL 94 V-0	SCALE	1:1	SHEET	1 OF 1
ITEM	PART NAME	PART NO.	MATERILAS	FINISHED	DRAWING NO.	C-DS1001-01 - XXXXXXX		

晨翔电子有限公司
CONNFLY CONNFLY ELECTRONIC CO. LTD

REV.	DESCRIPTION	DRAWN	CHECKED	APPROVED
A	NEW RELEASE	LL 09/26/06'	~	LJC 09/26/06'
B	新增加单排, 双排规格	LL 11/29/06'		

NOTES:

- MATERIAL
 - INSULATOR: POLYESTER (UL 94V-0).
 - CONTACT: BRASS.
 - FINISH: TIN PLATED.
- SPECIFICATION
 - CURRENT RATING: 1.0A/pin max.
 - VOLTAGE RATING: 60V AV/DC.
 - CONTACT RESISTANCE: 20mΩ max.
 - INSULATION RESISTANCE: 1000MΩ min.
 - WITHSTANDING VOLTAGE: 500V AC/minute.
 - TEMPERATURE RANGE: -45°C to +105°C.
- PART NUMBER: DS1007
- PRODUCT NUMBER CODE:

DS1007 - X X X X X X

- L CENTRAL SUPPORT
- S: W/ CENTRAL SUPPORT
- X: W/o CENTRAL SUPPORT
- CLIP PLATING
- F6: 3u" Gold
- T1: Tin
- HOUSING MATERIAL
- S: PBT
- WIDTH (DIM D)
- N: 7.62mm (06-24P)
- W: 15.24mm (24-40P)
- X: 1*40 & 2*40 only
- PIN PLATING
- T1: Tin
- CLIP TYPE
- B: 4 FINGERS
- No. OF CONTACTS
- 06 08 14 16 18
- 20 24 28 32 40

Ⓑ 1*1~1*40
2*1~2*40

Dimension

Position	A±0.5	B±0.2	C±0.3	D±0.2
06	7.62	5.08	10.16	7.62
08	10.16	7.62	10.16	7.62
14	17.78	15.24	10.16	7.62
16	20.32	17.78	10.16	7.62
18	22.86	20.34	10.16	7.62
20	25.40	22.86	10.16	7.62
24	30.48	27.94	10.16	7.62
28	35.56	33.02	10.16	7.62
24	30.48	27.94	17.78	15.24
28	35.56	33.02	17.78	15.24
32	40.64	38.10	17.78	15.24
40	50.80	48.26	17.78	15.24

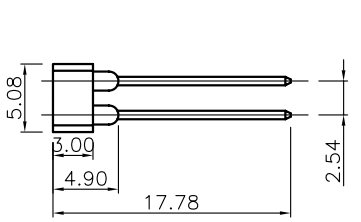
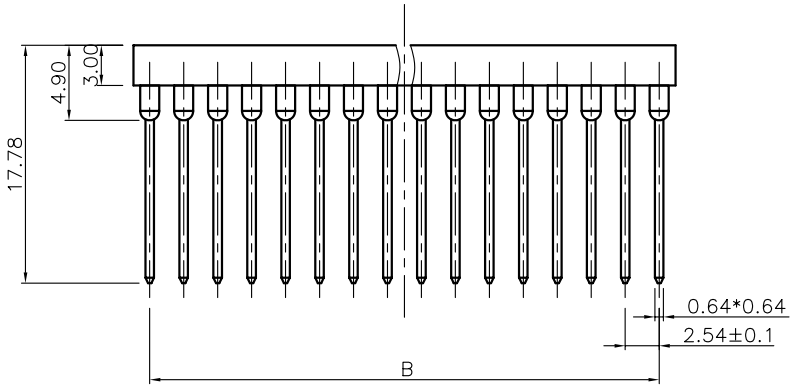
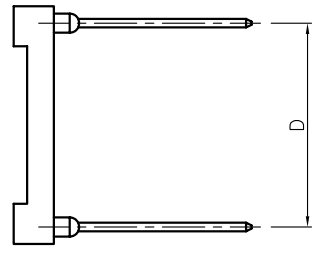
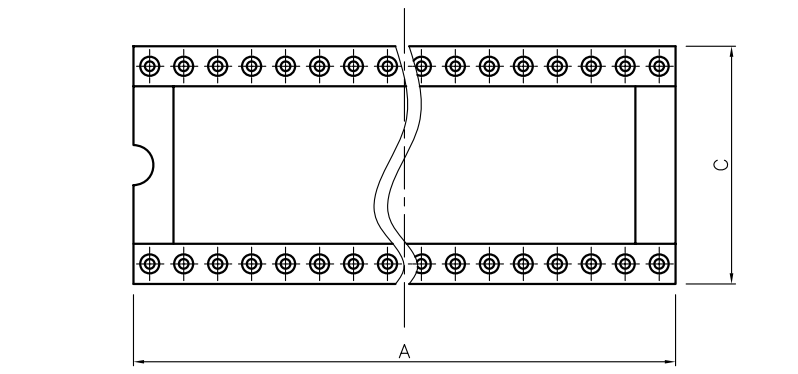

Ⓑ Dual rows

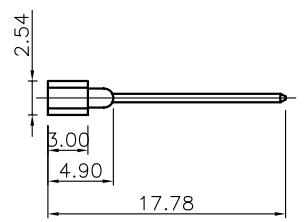

Ⓑ Single row

GENERAL TOLERANCE		ANGLE TOLERANCE	
X.	±0.60	X.	±5°
.X	±0.38	.X	±3°
.XX	±0.25	.XX	±2°

PROJECTION	TITLE	DIP IC SOCKET WIRE WRAP TYPE STANDARD 17.78mm LENGTH	
UNITS	mm	SHEET SIZE	A4
SHEET SIZE	A4	SERIES	DS1007 SERIES

DRAWING TYPE	CUSTOMER		
SCALE	1:1	SHEET	10F1
DRAWING NO.	C-DS1007-XXXXXXX		

晨翔电子有限公司
CONNFLY CONNFLY ELECTRONIC CO. LTD

REV.	DESCRIPTION	DRAWN	CHECKED	APPROVED
A	NEW RELEASE	LJH 05/24/05'		

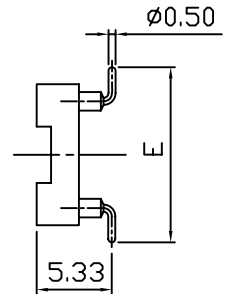
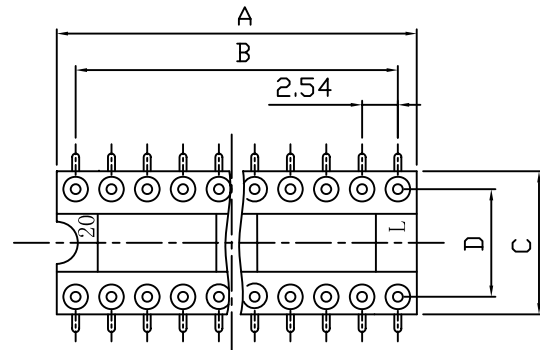

NOTES:

- ELECTRICAL CHARACTERISTICS:
 - CONTACT RESISTANCE: 20mΩ Max. INITIAL.
 - DIELECTRIC WITHSTANDING VOLTAGE: 500V AC(rms) FOR 1 MINUTE.
 - INSULATION RESISTANCE: 1000MΩ Min.
- ENVIRONMENT CHARACTERISTICS:
 - TEMPERATURE: -40°C~+105°C.
- PART NUMBER: DS1001-02
- PRODUCT NUMBER CODE:

DS1001-02 - X X X X

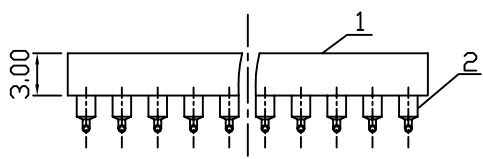

Position	Dimension				
	A±0.5	B±0.2	C	D±0.1	E±0.3
06	7.60	5.08	10.14	7.62	12.42
08	10.16	7.62	10.16	7.62	12.42
14	17.16	15.24	10.16	7.62	12.42
16	20.32	17.78	10.16	7.62	12.42
18	22.86	20.32	10.16	7.62	12.42
20	25.40	22.86	10.16	7.62	12.42
24	30.48	27.94	10.16	7.62	12.42
28	35.56	33.02	10.16	7.62	12.42
24	30.48	27.94	17.78	15.24	20.04
28	35.56	33.02	17.78	15.24	20.04
32	40.62	38.10	17.78	15.24	20.04
40	51.00	48.26	17.78	15.24	20.04

Clip plating
 1: Tin 150u"
 2: Tin 200u"
 3: G/F
 4: Gold 3u"
 5: Gold 10u"
 6: Gold 15u"
 Pin plating
 1: Tin 150u"
 2: Tin 200u"
 3: G/F
 4: Gold 3u"
 5: Gold 10u"
 6: Gold 15u"
 Width
 N: 7.62mm
 W: 15.24mm
 No. of contacts
 06 08 12 14 16 18
 20 24 28 32 40

GENERAL TOLERANCE		ANGLE TOLERANCE	
X.	±0.60	X.	±5°
.X	±0.38	.X	±3°
.XX	±0.25	.XX	±2°

PROJECTION		TITLE	SMT IC SOCKET PITCH 2.54mm(0.100")
UNITS	mm	SHEET SIZE	A4
SHEET SIZE	A4	SERIES	DS1001-02 SERIES

2	CONTACT		COPPER ALLOY	GOLD PLATED	DRAWING TYPE	CUSTOMER		
1	HOUSING		THERMOPLASTIC	UL 94 V-0	SCALE	1:1	SHEET	1 OF 1
ITEM	PART NAME	PART NO.	MATERILAS	FINISHED	DRAWING NO.	C-DS1001-02-XXXXX		

晨翔电子有限公司
CONNFLY CONNFLY ELECTRONIC CO. LTD

REV.	DESCRIPTION	DRAWN	CHECKED	APPROVED
A	NEW RELEASE	LJH 07/11/05'		

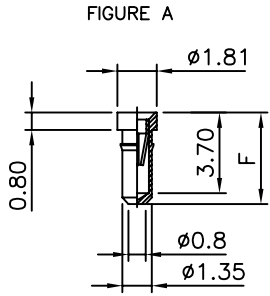
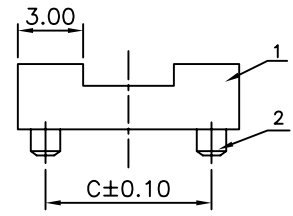
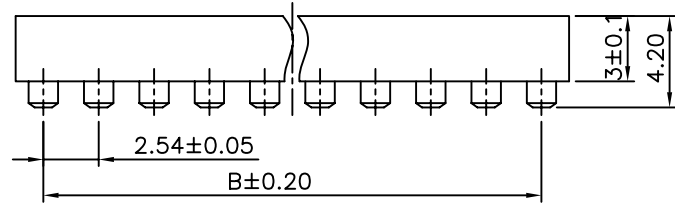
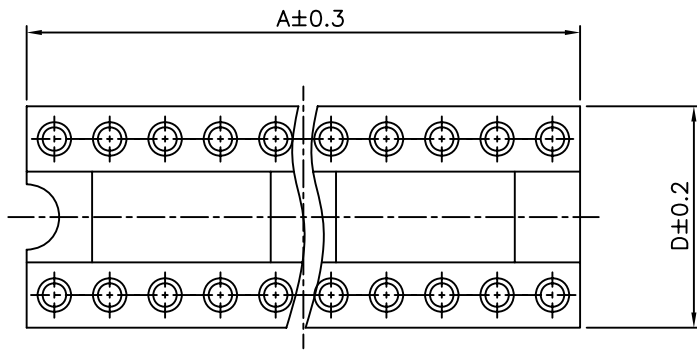

- NOTES:
- ELECTRICAL CHARACTERISTICS:
 - CONTACT RESISTANCE: 20mΩ Max.
 - DIELECTRIC WITHSTANDING VOLTAGE: 500V AC(rms) FOR 1 MINUTE.
 - INSULATION RESISTANCE: 1000MΩ Min.
 - ENVIRONMENT CHARACTERISTICS:
 - TEMPERATURE: -40°C~+105°C.
 - PART NUMBER: DS1002-04
 - PRODUCT NUMBER CODE:
DS1002-04 - X X X X X

- Pin length
F: 4.20mm
- Clip plating
 - Tin 150u"
 - Tin 200u"
 - G/F
 - Gold 3u"
 - Gold 10u"
 - Gold 15u"
- Pin plating
 - Tin 150u"
 - Tin 200u"
 - G/F
 - Gold 3u"
 - Gold 10u"
 - Gold 15u"
- Width(DIM C)
 - N: 7.62mm
 - W: 15.24mm
- No. of contacts
 - 06 08 14 16 18
 - 20 24 28 32 40
- Series No.
DS1002-04

Position	Dimension			
	A	B	C	D
06	7.62	5.08	7.62	10.16
08	10.16	7.62	7.62	10.16
14	17.78	15.24	7.62	10.16
16	20.32	17.78	7.62	10.16
18	22.86	20.32	7.62	10.16
20	25.40	22.86	7.62	10.16
24	30.48	27.94	7.62	10.16
28	35.56	33.02	7.62	10.16
24	30.48	27.94	15.24	17.78
28	35.56	33.02	15.24	17.78
32	40.64	38.10	15.24	17.78
40	51.00	48.26	15.24	17.78

GENERAL TOLERANCE	ANGLE TOLERANCE
X. ±0.60	X. ±5°
.X ±0.38	.X ±3°
.XX ±0.25	.XX ±2°

PROJECTION		TITLE	SMT IC SOCKET PITCH 2.54mm
UNITS	mm		
SHEET SIZE	A4	SERIES	DS1002-04 SERIES

2	CONTACT		COPPER ALLOY	GOLD PLATED	DRAWING TYPE	CUSTOMER		
1	HOUSING		THERMOPLASTIC	UL 94 V-0	SCALE	1:1	SHEET	1 OF 1
ITEM	PART NAME	PART NO.	MATERILAS	FINISHED	DRAWING NO.	C-DS1002-04-XXXXX		

晨翔电子有限公司
CONNFLY CONNFLY ELECTRONIC CO. LTD

REV.	DESCRIPTION	DRAWN	CHECKED	APPROVED
A	NEW RELEASE	LL 09/26/06'	~	LJC 09/26/06'
B	新增加单排, 双排规格	LL 11/29/06'		

NOTES:

- MATERIAL
 - INSULATOR: POLYESTER(UL 94V-0).
 - CONTACT: BRASS.
 - FINISH: TIN PLATED.
- SPECIFICATION
 - CURRENT RATING: 1.0A/pin max.
 - VOLTAGE RATING: 60V AV/DC.
 - CONTACT RESISTANCE: 20mΩ max.
 - INSULATION RESISTANCE: 1000MΩ min.
 - WITHSTANDING VOLTAGE: 500V AC/minute.
 - TEMPERATURE RANGE: -45°C to +105°C.
- PART NUMBER: DS1007
- PRODUCT NUMBER CODE:

DS1007 - X X X X X X

- CENTRAL SUPPORT
- S: W/ CENTRAL SUPPORT
- X: W/o CENTRAL SUPPORT
- CLIP PLATING
- F6: 3u" Gold
- T1: Tin
- HOUSING MATERIAL
- S: PBT
- WIDTH(DIM D)
- N: 7.62mm(06-24P)
- W: 15.24mm(24-40P)
- X: 1*40&2*40 only
- PIN PLATING
- T1: Tin
- CLIP TYPE
- B: 4 FINGERS
- No.OF CONTACTS
- 06 08 14 16 18
- 20 24 28 32 40

Ⓑ 1*1~1*40
2*1~2*40

Dimension

Position	A±0.5	B±0.2	C±0.3	D±0.2
06	7.62	5.08	10.16	7.62
08	10.16	7.62	10.16	7.62
14	17.78	15.24	10.16	7.62
16	20.32	17.78	10.16	7.62
18	22.86	20.34	10.16	7.62
20	25.40	22.86	10.16	7.62
24	30.48	27.94	10.16	7.62
28	35.56	33.02	10.16	7.62
24	30.48	27.94	17.78	15.24
28	35.56	33.02	17.78	15.24
32	40.64	38.10	17.78	15.24
40	50.80	48.26	17.78	15.24

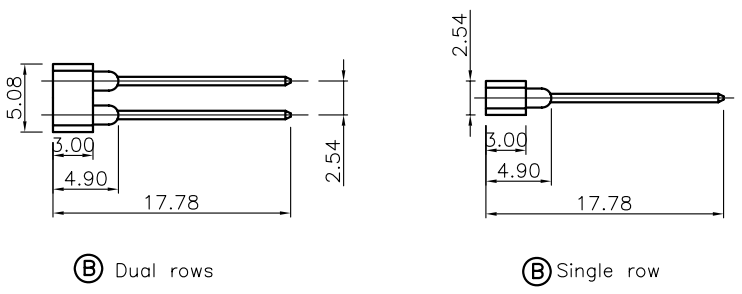
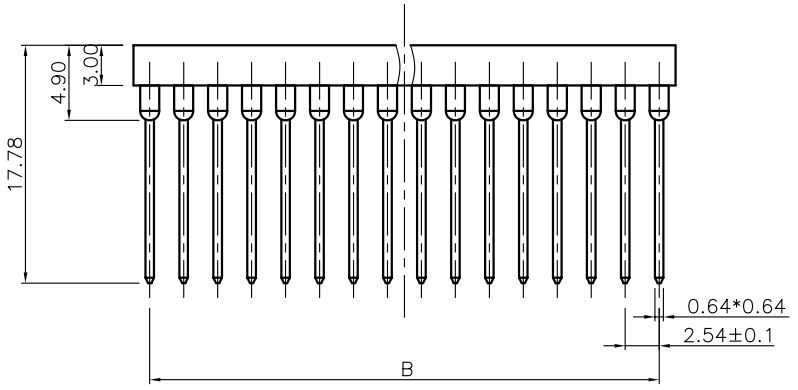
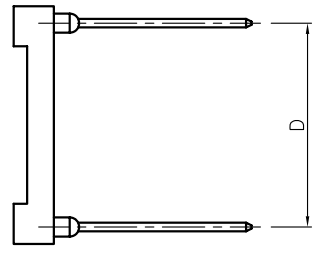
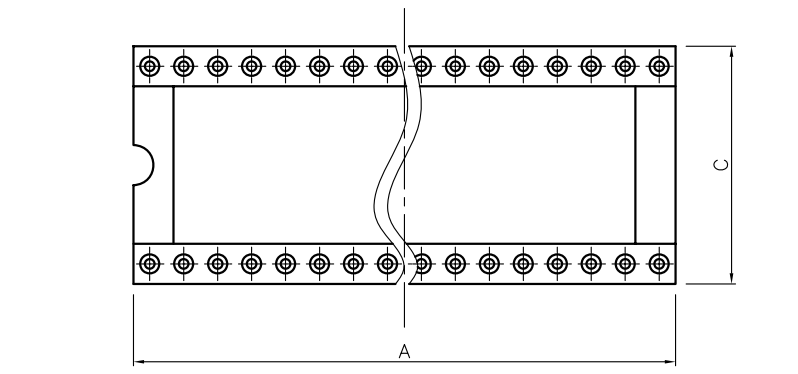

GENERAL TOLERANCE		ANGLE TOLERANCE	
X.	±0.60	X.	±5°
.X	±0.38	.X	±3°
.XX	±0.25	.XX	±2°

PROJECTION	TITLE	DIP IC SOCKET WIRE WRAP TYPE STANDARD 17.78mm LENGTH	
UNITS	mm	SHEET SIZE	A4
SHEET SIZE	A4	SERIES	DS1007 SERIES

DRAWING TYPE	CUSTOMER		
SCALE	1:1	SHEET	10F1
DRAWING NO.	C-DS1007-XXXXXXX		

晨翔电子有限公司
CONNFLY CONNFLY ELECTRONIC CO. LTD

REV.	DESCRIPTION	DRAWN	CHECKED	APPROVED
A	NEW RELEASE	LJH 05/24/05'		

Dual rows

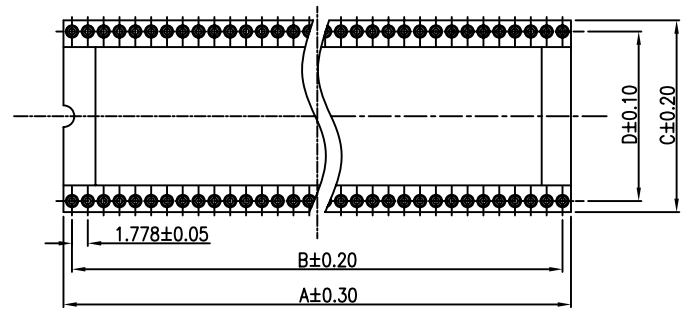
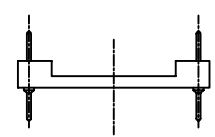
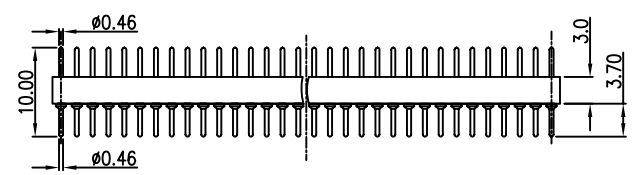

Single row

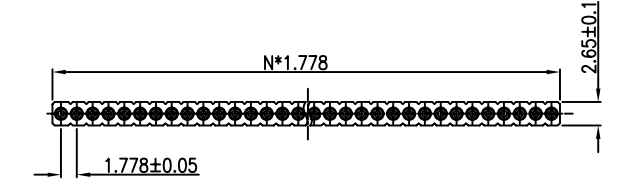
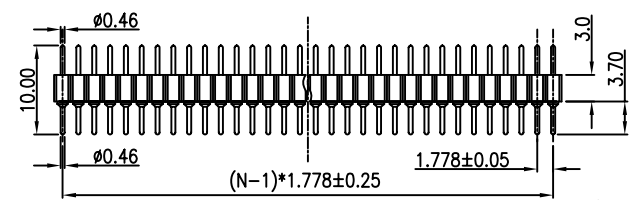

NOTES:

- ELECTRICAL CHARACTERISTICS:
 - CONTACT RESISTANCE: 20mΩ Max.
 - DIELECTRIC WITHSTANDING VOLTAGE: 500V AC(rms) FOR 1 MINUTE.
 - INSULATION RESISTANCE: 1000MΩ Min.
- ENVIRONMENT CHARACTERISTICS:
 - TEMPERATURE: -40°C~+105°C.
- PART NUMBER: DS1003-03
- PRODUCT NUMBER CODE:

DS1003-03 - X X X X

- PIN LENGTH
1: 10.00mm
- PIN PLATING
1: Tin 150u"
2: Tin 200u"
3: G/F
4: Gold 3u"
5: Gold 10u"
6: Gold 15u"
- ROW & WIDTH
X: 1*40&2*40 only
1: 10.16mm
2: 15.24mm
3: 19.05mm
- No. OF CONTACTS
24 28 42 48 52 56 64
1*1 to 1*40
2*1 to 2*40
- SERIES No.
DS1003-03

Position	Dimension			
	A	B	C	D
24	21.46	19.56	12.65	10.16
28	25.01	23.11	12.65	10.16
42	37.46	35.56	17.73	15.24
48	42.79	40.89	17.73	15.24
52	46.35	44.45	17.73	15.24
56	49.91	48.01	17.73	15.24
64	57.04	55.12	21.54	19.05

GENERAL TOLERANCE		ANGLE TOLERANCE	
X.	±0.60	X.	±5°
.X	±0.38	.X	±3°
.XX	±0.25	.XX	±2°

PROJECTION		TITLE	MACHINE PIN MEADER IC DIP PITCH 1.778mm
UNITS	mm	SHEET SIZE	A4
SHEET SIZE	A4	SERIES	DS1003-03 SERIES

2	CONTACT		COPPER ALLOY	GOLD PLATED	DRAWING TYPE	CUSTOMER		
1	HOUSING		THERMOPLASTIC	UL 94 V-0	SCALE	1:1	SHEET	1 OF 1
ITEM	PART NAME	PART NO.	MATERILAS	FINISHED	DRAWING NO.	C-DS1003-03-XXXX		

晨翔电子有限公司
CONNFLY CONNFLY ELECTRONIC CO. LTD

REV.	DESCRIPTION	DRAWN	CHECKED	APPROVED
A	NEW RELEASE	LJH 04/27/05'	~	LJC 04/27/05'
B	整理图面	YCH 11/26/07'	~	

NOTES:

- ELECTRICAL CHARACTERISTICS:
 - CONTACT RESISTANCE: 20mΩ Max.
 - DIELECTRIC WITHSTANDING VOLTAGE: 500V AC(rms) FOR 1 MINUTE.
 - INSULATION RESISTANCE: 1000MΩ Min.
- ENVIRONMENT CHARACTERISTICS:
 - EMPERATURE: -40°C~+105°C.
- PART NUMBER: DS1003-01
- PRODUCT NUMBER CODE:

DS1003-01 - X X X X X

- CENTRAL SUPPORT
S: W/ CENTRAL SUPPORT
X: W/O CENTRAL SUPPORT
- CONTACT TYPE
1: TYPE 1
2: TYPE 2
3: TYPE 3
- PIN PLATING
F1: Full gold flash
- WIDTH(DIM D)
N:7.62mm
W:15.24mm
- No.OF CONTACTS
06 08 14 16 18
20 24 28 32 40
- SERIES No.
DS1003-01

Dimension

Position	A	B	C	D
06	7.62	5.08	10.16	7.62
08	10.16	7.62	10.16	7.62
14	17.78	15.24	10.16	7.62
16	20.32	17.78	10.16	7.62
18	22.86	20.32	10.16	7.62
20	25.40	22.86	10.16	7.62
24	30.48	27.94	10.16	7.62
28	35.56	33.02	10.16	7.62
24	30.48	27.94	17.78	15.24
28	35.56	33.02	17.78	15.24
32	40.64	38.10	17.78	15.24
40	50.80	48.26	17.78	15.24

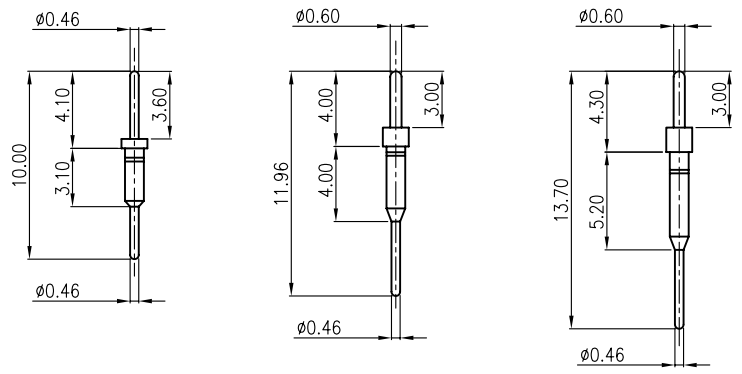
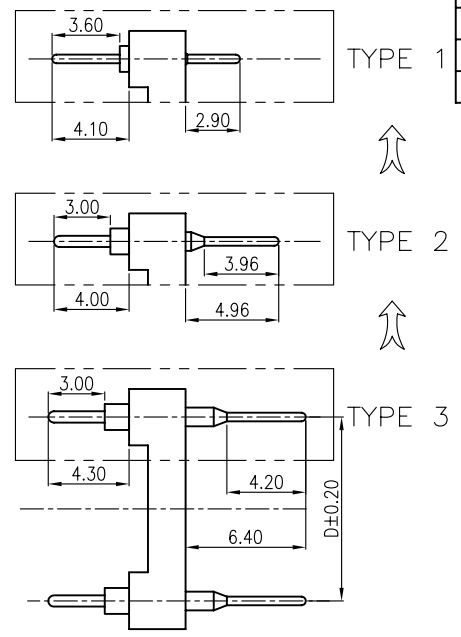
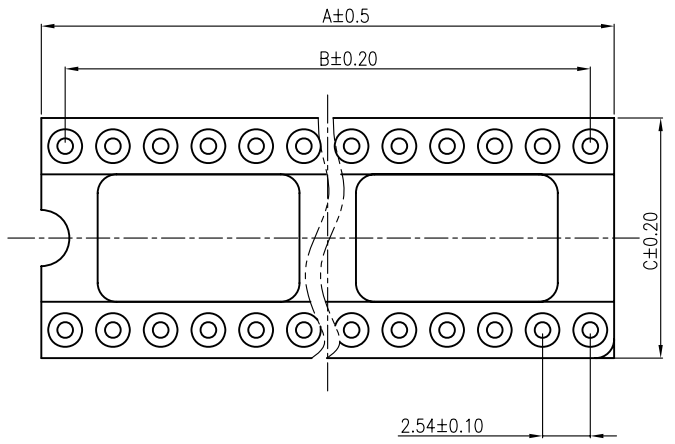

TYPE 1 TYPE 2 TYPE 3

TYPE1/2/3 DIA.(TOLERANCE=±0.05)

GENERAL TOLERANCE		ANGLE TOLERANCE		PROJECTION		TITLE	MACHINE PIN HEADER IC PITCH 2.54mm		
X.	±0.60	X.	±5°	UNITS	mm				
.X	±0.38	.X	±3'	SHEET SIZE	A4	SERIES	DS1003-01 SERIES		
.XX	±0.25	.XX	±2'	晨翔电子有限公司 CONNFLY CONNFLY ELECTRONIC CO. LTD					
DRAWING TYPE		CUSTOMER							
SCALE	1:1	SHEET	10F1						
DRAWING NO.		C-DS1003-01-XXXXX-B							

REV.	DESCRIPTION	DRAWN	CHECKED	APPROVED
A	NEW RELEASE	LJH 04/27/05'	~	LJC 04/27/05'
B	增加单双排示意图及料号	YCH 07/27/07'	~	

NOTES:

- ELECTRICAL CHARACTERISTICS:
 - CONTACT RESISTANCE: 20mΩ Max.
 - DIELECTRIC WITHSTANDING VOLTAGE: 500V AC(rms) FOR 1 MINUTE.
 - INSULATION RESISTANCE: 1000MΩ Min.
- ENVIRONMENT CHARACTERISTICS:
 - TEMPERATURE: -40°C~+105°C.
- PART NUMBER: DS1003-02
- PRODUCT NUMBER CODE:

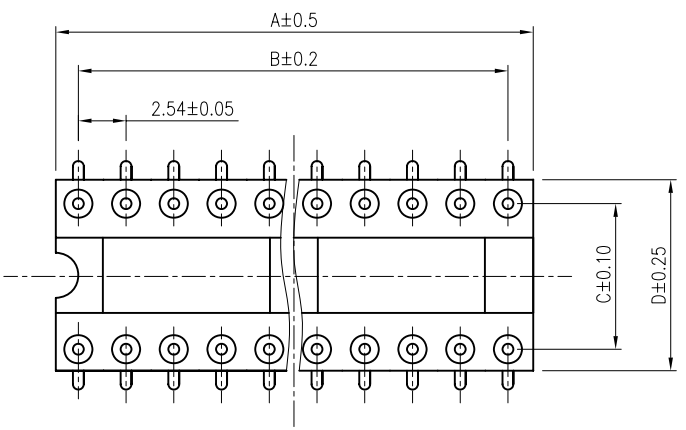
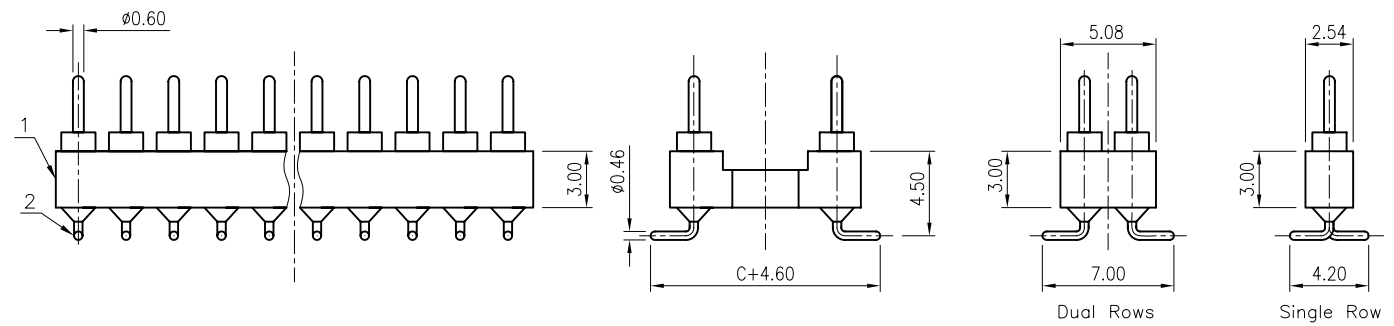

N:NUMBER OF CONTACTS/2

Dimension

Position	A	B	C	D
06	7.60	5.08	10.16	7.62
08	10.16	7.62	10.16	7.62
14	17.16	15.24	10.16	7.62
16	20.32	17.78	10.16	7.62
18	22.86	20.32	10.16	7.62
20	25.40	22.86	10.16	7.62
24	30.48	27.94	10.16	7.62
28	35.56	33.02	10.16	7.62
24	30.48	27.94	17.78	15.24
28	35.56	33.02	17.78	15.24
32	40.62	38.10	17.78	15.24
40	50.80	48.26	17.78	15.24

DS1003-02 - X X X

PIN PLATING
 1: Tin 150u"
 2: Tin 200u"
 3: G/F
 4: Gold 3u"
 5: Gold 10u"
 6: Gold 15u"

WIDTH(DIM. C)
 N: 7.62mm
 W: 15.24mm

No.OF CONTACTS
 06 08 14 16 18
 20 24 28 32 40

1*1 to 1*40
 2*1 to 2*40

SERIES No.
 DS1003-02

GENERAL TOLERANCE		ANGLE TOLERANCE	
X.	±0.60	X.	±5'
.X	±0.38	.X	±3'
.XX	±0.25	.XX	±2'

PROJECTION	TITLE
UNITS	MACHINE PIN HEADER IC SMT PITCH 2.54mm
SHEET SIZE	SERIES DS1003-02 SERIES

ITEM	PART NAME	PART NO.	MATERILAS	FINISHED	DRAWING NO.	CUSTOMER
2	CONTACT		COPPER ALLOY	GOLD PLATED	DRAWING TYPE	CUSTOMER
1	HOUSING		THERMOPLASTIC	UL 94 V-0	SCALE	1:1 SHEET 10F1
					DRAWING NO.	C-DS1003-02-XXXX

 晨翔电子有限公司
CONNFLY CONNFLY ELECTRONIC CO. LTD