

REV.	DESCRIPTION	DRAWN	CHECKED	APPROVED
A	NEW RELEASE	YCH 05/08/12'	~	

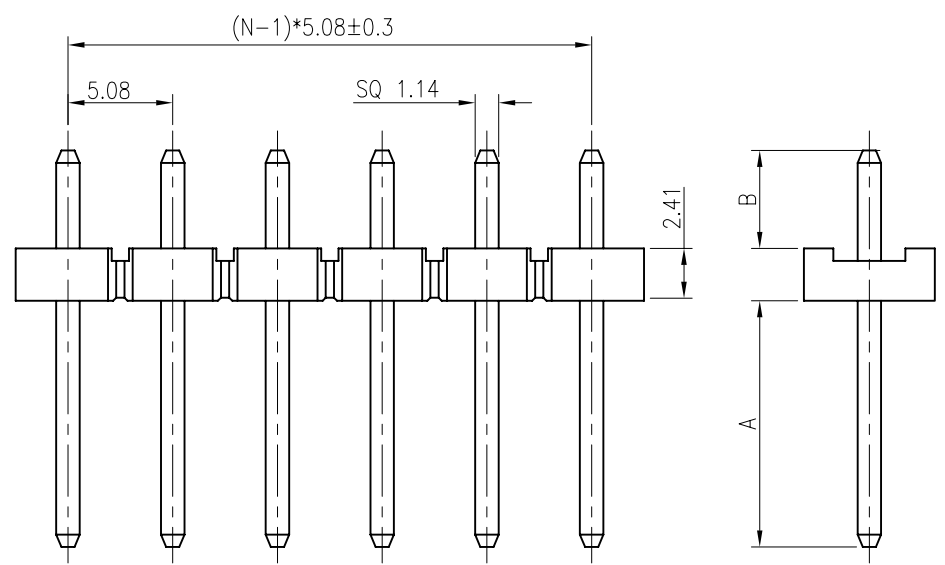
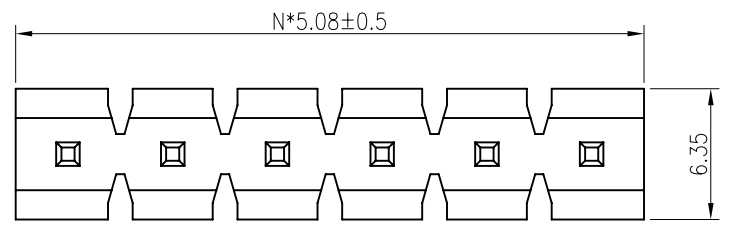

NOTES:

- ELECTRICAL CHARACTERISTICS:
 - CONTACT RESISTANCE: 20mΩ Max.
 - DIELECTRIC WITHSTANDING VOLTAGE: 500V AC(rms) FOR 1 MINUTE.
 - INSULATION RESISTANCE: 1000MΩ Min.
- ENVIRONMENT CHARACTERISTICS:
 - OPERATING TEMPERATURE: -40°C~+105°C.
- PRODUCT NUMBER CODE:

DS1021-06- X X X X

TABLE A & DIM. TYPE
1: TYPE 1
2: TYPE 2
...

CONTACT PLATING
F1: FULL GOLD FLASH
6: TIN

MOUNTING TYPE
S: Straight TYPE

No. OF CONTACTS
1*2~1*20

TABLE A:

TYPE	Dimension	
	A	B
1	11.94	4.57
2	13.21	4.57
3		
4		
5		
6		
7		
8		
9		
10		

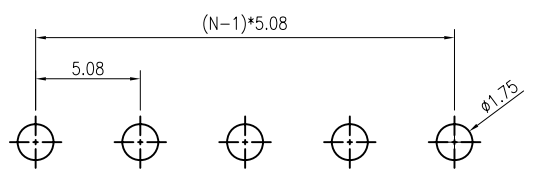

GENERAL TOLERANCE		ANGLE TOLERANCE		PROJECTION		TITLE	PIN HEADER PITCH 5.08mm	
X.	±0.60	X.	±5°	UNITS	mm		V/T TYPE	
.X	±0.38	.X	±3'	SHEET SIZE	A4	SERIES	DS1021-06 SERIES	
.XX	±0.25	.XX	±2'	晨翔电子有限公司 CONNFLY CONNFLY ELECTRONIC CO. LTD				
DRAWING TYPE		CUSTOMER						
SCALE		SHEET 1 OF 2						
DRAWING NO.		C-DS1021-06-1*XXX						

REV.	DESCRIPTION	DRAWN	CHECKED	APPROVED
A	NEW RELEASE	YCH 05/09/12'	~	

N:NUMBER OF CONTACTS

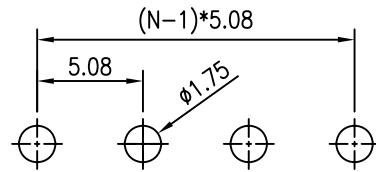
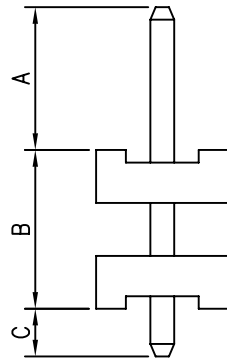
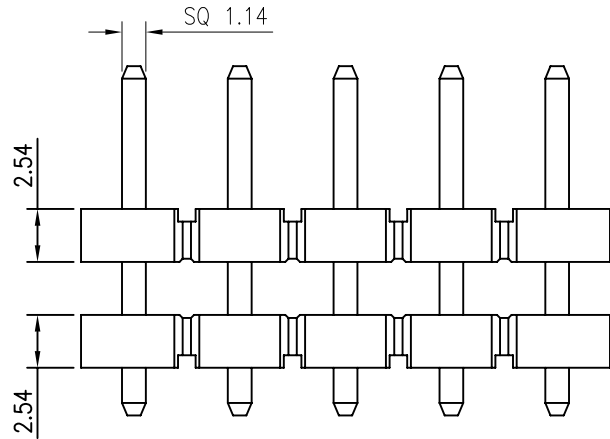
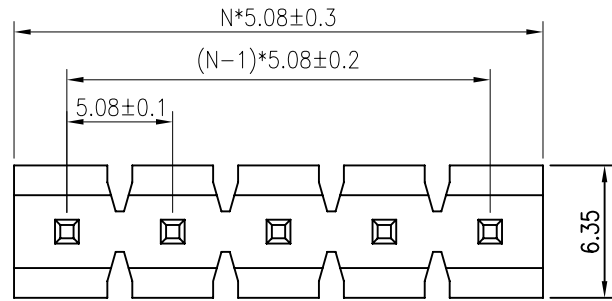

RECOMMEND PCB LAYOUT
(TOLERANCE=±0.05)

NOTES:

- MATERIAL
 - INSULATOR:THERMOPLASTIC UL94 V-0.
 - CONTACT MATERIAL:COPPER ALLOY.
- SPECIFICATION
 - CURRENT RATING:8Amp.
 - INSULATION RESISTANCE:1000MΩ Min.
 - DIELECTRIC WITHSTANDING:600VAC.
 - CONTACT RESISTANCE:50mΩ Max.
 - OPERATING TEMPERATURE:-40°C TO+105°C.
- PART NUMBER: DS1029-13
- PRODUCT NUMBER CODE:

DS1029-13 - X X X X X

DIM.A B C TYPE
1: TYPE 1
2: TYPE 2
.....

MOUNTING TYPE
V:VERTICAL TYPE

HOUSING COLOR
B:BLACK

CONNECTOR PLATING
6: FULL TIN

CONNECT TYPE
P:PLUG

No.OF CONTACTS
1*1-1*20

TABLE A:

TYPE	Dimension		
	A	B	C
1	6.86	7.62	2.29
2			
3			
4			
5			
6			
7			
8			
9			
10			

GENERAL TOLERANCE		ANGLE TOLERANCE		PROJECTION		TITLE	SINGLE ROW DUAL HOUSING PIN HEADER
X.	±0.60	X.	±5°	UNITS	mm		PITCH 5.08mm V/T TYPE
.X	±0.38	.X	±3°	SHEET SIZE	A4	SERIES	DS1029-13 SERIES
.XX	±0.25	.XX	±2°	晨翔电子有限公司 CONNFLY CONNFLY ELECTRONIC CO. LTD			
DRAWING TYPE		CUSTOMER					
SCALE	1:1	SHEET	1 OF 2				
DRAWING NO.		C-DS1029-13-XXXXXX					

REV.	DESCRIPTION	DRAWN	CHECKED	APPROVED
A	NEW RELEASE	YCH 05/08/12'	~	

N=NUMBER OF CONTACTS

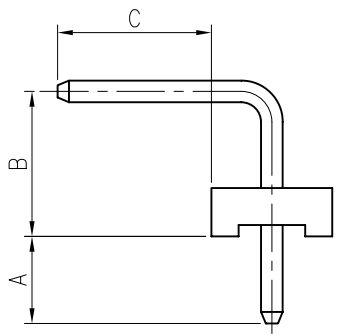
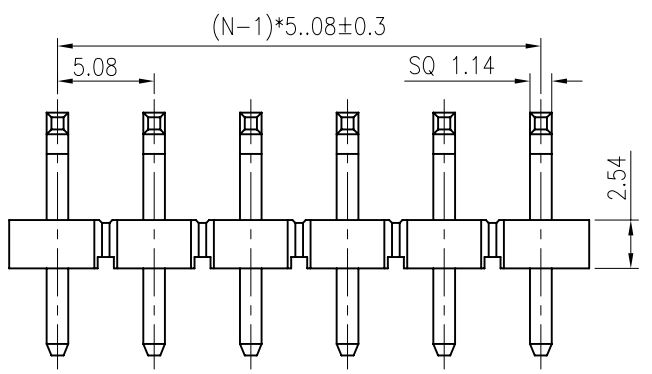
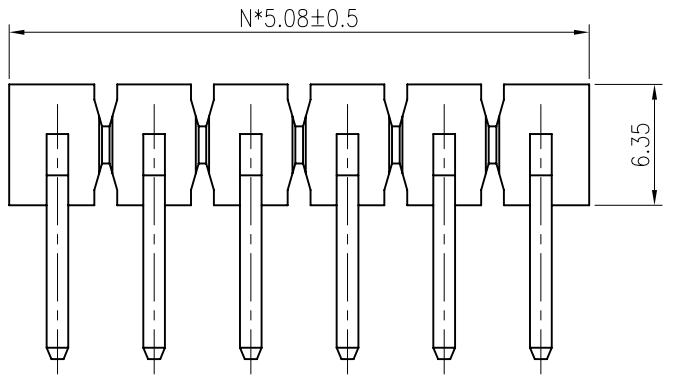

NOTES:

- ELECTRICAL CHARACTERISTICS:
 - CONTACT RESISTANCE: 20mΩ Max.
 - DIELECTRIC WITHSTANDING VOLTAGE: 500V AC(rms) FOR 1 MINUTE.
 - INSULATION RESISTANCE: 1000MΩ Min.
- ENVIRONMENT CHARACTERISTICS:
 - OPERATING TEMPERATURE: -40°C~+105°C.
- PRODUCT NUMBER CODE:
DS1022-16- X X X X

TABLE A & DIM. TYPE
1: TYPE 1
2: TYPE 2
.....

CONTACT PLATING
F1: FULL GOLD FLASH
6: TIN

MOUNTING TYPE
R: R/A

No. OF CONTACTS
1*2~1*20

TABLE A:

TYPE	Dimension		
	A	B	C
1	4.57	7.62	8.08
2	3.96	7.62	13.82
3			
4			
5			
6			
7			
8			
9			
10			

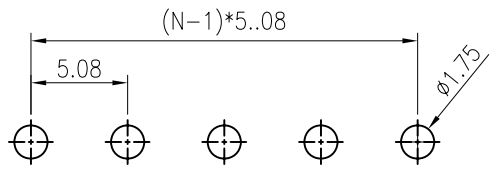

RECOMMEND PCB LAYOUT
(TOLERANCE=±0.05)

GENERAL TOLERANCE		ANGLE TOLERANCE		PROJECTION		TITLE	PIN HEADER PITCH 5.08mm	
X.	±0.60	X.	±5°	UNITS	mm		SINGLE R/A TYPE	
.X	±0.38	.X	±3°	SHEET SIZE	A4	SERIES	DS1022-16 SERIES	
.XX	±0.25	.XX	±2°			晨翔电子有限公司 CONNFLY CONNFLY ELECTRONIC CO. LTD		
DRAWING TYPE		CUSTOMER						
SCALE		SHEET		1 OF 2				
DRAWING NO.		C-DS1022-16-1*XXX						

REV.	DESCRIPTION	DRAWN	CHECKED	APPROVED
A	NEW RELEASE	LJC 05/04/08'		

NOTES:

- MATERIALS
 - CONTACT MATERIAL: COPPER ALLOY.
 - INSULATOR: PA-46
- SPECIFICATIONS
 - CURRENT RATING: 3A.
 - OPERATING TEMPERATURE: -40°C TO +105°C.
 - INSULATION RESISTANCE: 1000MΩ MIN.
 - CONTACT RESISTANCE: 30mΩ MAX.
 - DIELECTRIC WITHSTANDING: 500 VAC.

- PART NUMBER: DS1022-05
- PRODUCT NUMBER CODE:

DS1022-05- X X X X

DIM A B C TYPE
1: TYPE 1

CONTACT PLATING
8: FULL GOLD FLASH
6: FULL TIN

HOUSING COLOR
B: BLACK

No. OF CONTACTS
1*3

TYPE	DIM A	DIM B	DIM C
1	13.20	8.20	1.80

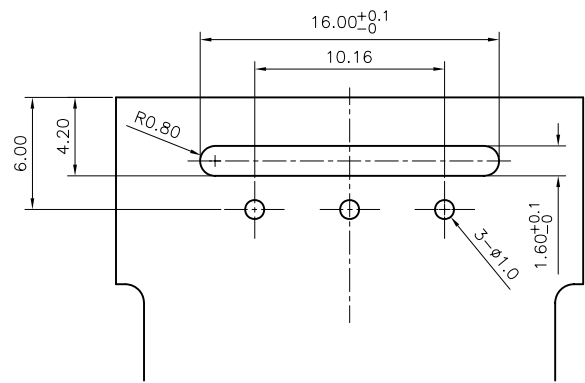
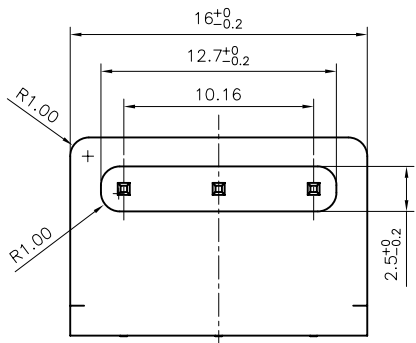
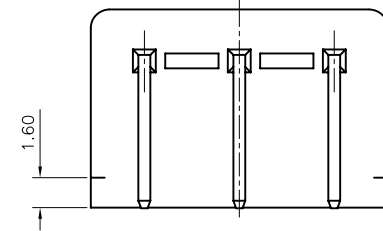
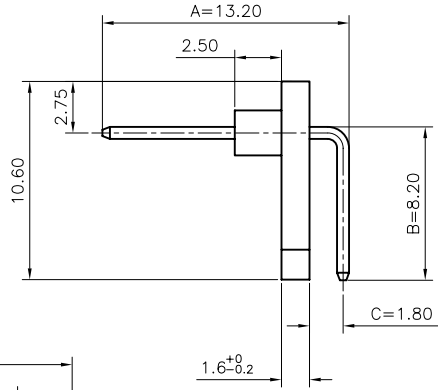
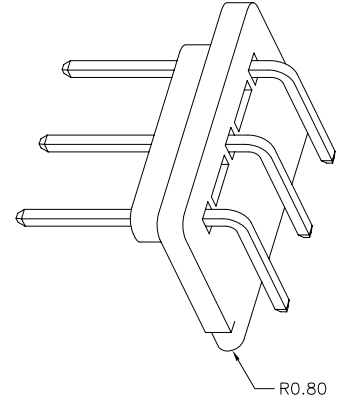
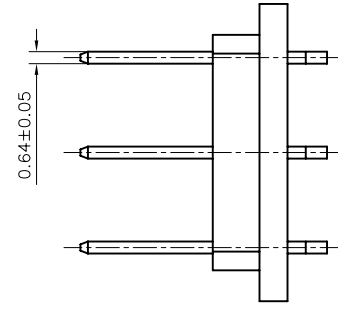

RECOMMEND P.C.B BOARD HOLE LAYOUT
TOLERANCE=±0.05

GENERAL TOLERANCE		ANGLE TOLERANCE		PROJECTION		TITLE	PIN HEADER PITCH 5.08mm	
X.	±0.60	X.	±5°	UNITS	mm		SPECIAL R/A TYPE	
.X	±0.38	.X	±3°	SHEET SIZE	A4	SERIES	DS1022-05 SERIES	
.XX	±0.25	.XX	±2°	晨翔电子有限公司 CONNFLY CONNFLY ELECTRONIC CO. LTD				
DRAWING TYPE		CUSTOMER						
SCALE	1:1	SHEET	1 OF 1					
DRAWING NO.		C-DS1022-05-1*XXX						

REV.	DESCRIPTION	DRAWN	CHECKED	APPROVED
A	NEW RELEASE	YCH 05/08/12'	~	

NOTES:

- ELECTRICAL CHARACTERISTICS:
 - CONTACT RESISTANCE: 20mΩ Max.
 - DIELECTRIC WITHSTANDING VOLTAGE: 500V AC(rms) FOR 1 MINUTE.
 - INSULATION RESISTANCE: 1000MΩ Min.
- ENVIRONMENT CHARACTERISTICS:
 - OPERATING TEMPERATURE: -40°C~+105°C.
- PRODUCT NUMBER CODE:

DS1022-15- X X X X X X X

PACKING TYPE
T: TRAY
R: TAPE ON REEL
B: TUBE

PICK UP SUPPORT
S: W/ PICK UP
X: W/O PICK UP

BEND TYPE
A: R1 TYPE
B: R2 TYPE

TABLE A & DIM. TYPE
1: TYPE 1
2: TYPE 2
.....

CONTACT PLATING
F1: FULL GOLD FLASH
6: TIN

MOUNTING TYPE
M: SMT

No. OF CONTACTS
1*2~1*20

TABLE A:

TYPE	Dimension	
	A	B
1	10.72	8.64
2	12.24	8.38
3		
4		
5		
6		
7		
8		
9		
10		

← R2 TYPE

← R1 TYPE

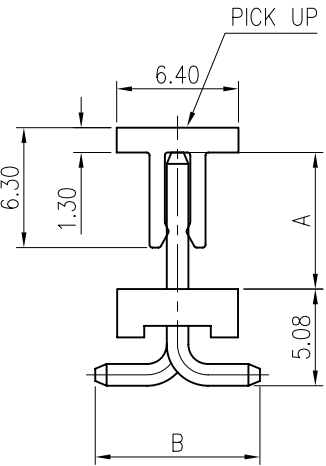

GENERAL TOLERANCE		ANGLE TOLERANCE	
X.	±0.60	X.	±5°
.X	±0.38	.X	±3°
.XX	±0.25	.XX	±2°

PROJECTION	TITLE	PIN HEADER PITCH 5.08mm	
UNITS	mm	SINGLE SMT TYPE	
SHEET SIZE	A4	SERIES	DS1022-15 SERIES

DRAWING TYPE	CUSTOMER		
SCALE	~	SHEET	1 OF 2
DRAWING NO.	C-DS1022-15-1*XXX		

晨翔电子有限公司
CONNFLY CONNFLY ELECTRONIC CO. LTD

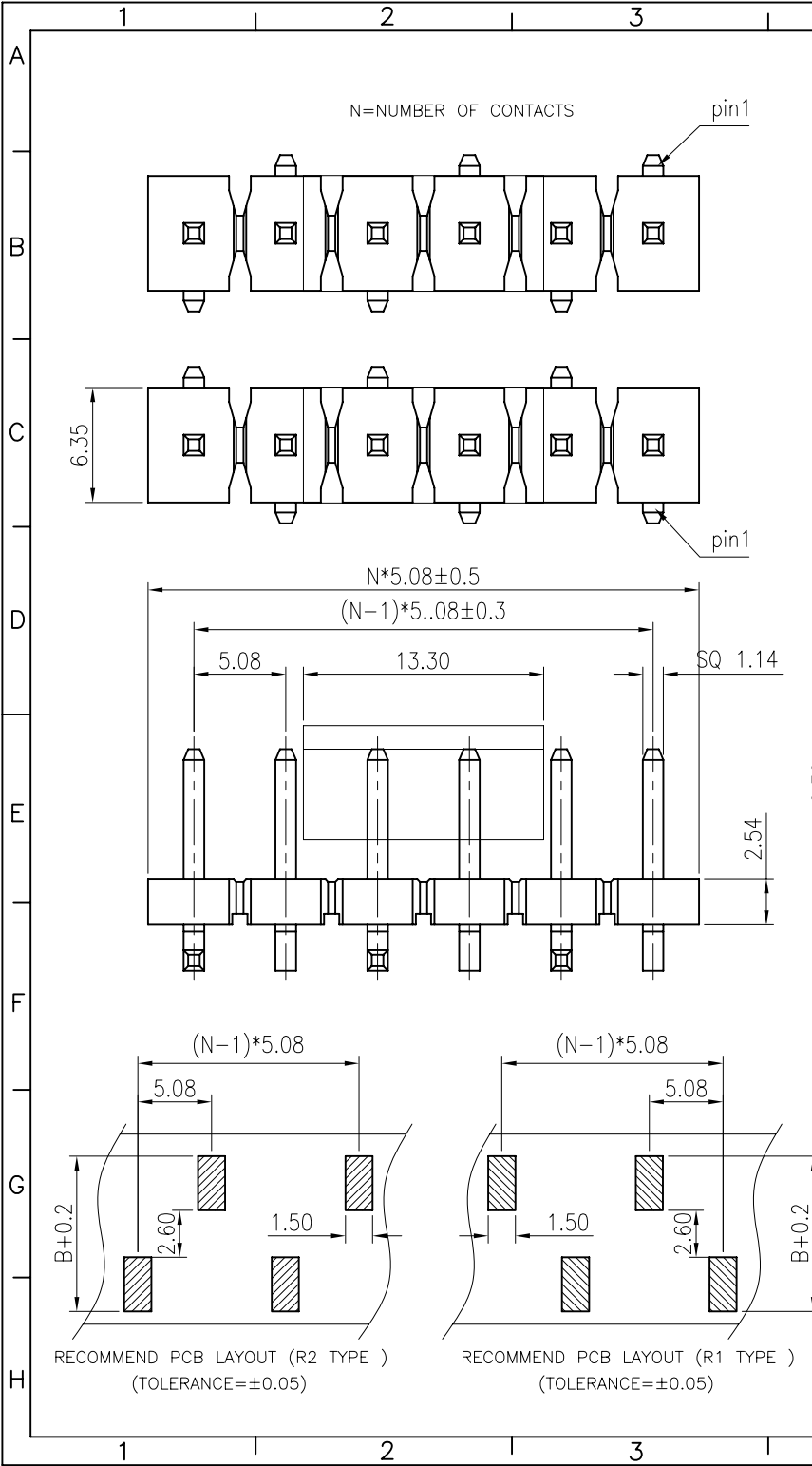

RECOMMEND PCB LAYOUT (R2 TYPE)
(TOLERANCE=±0.05)

RECOMMEND PCB LAYOUT (R1 TYPE)
(TOLERANCE=±0.05)

REV.	DESCRIPTION	DRAWN	CHECKED	APPROVED
A	NEW RELEASE	YCH 05/09/12'	~	

N:NUMBER OF CONTACTS

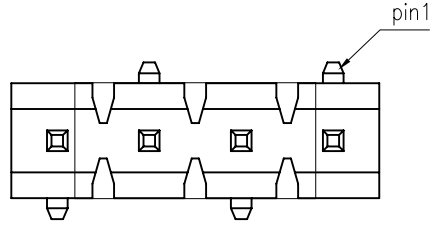

← R2 TYPE

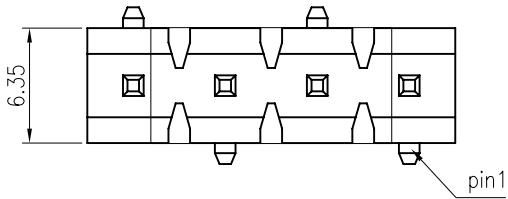

← R1 TYPE

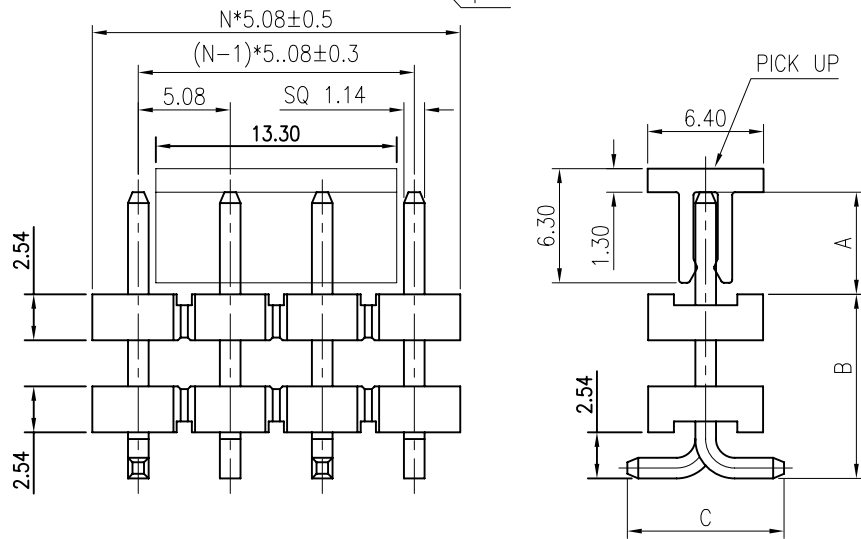

TABLE A:

TYPE	Dimension		
	A	B	C
1	5.64	10.16	8.64
2			
3			
4			
5			
6			
7			
8			
9			
10			

NOTES:

- MATERIAL
 - INSULATOR:THERMOPLASTIC UL94 V-0.
 - CONTACT MATERIAL:COPPER ALLOY.
- SPECIFICATION
 - CURRENT RATING:8Amp.
 - INSULATION RESISTANCE:1000MΩ Min.
 - DIELECTRIC WITHSTANDING:600VAC.
 - CONTACT RESISTANCE:50mΩ Max.
 - OPERATING TEMPERATURE:-40°C TO+105°C.
- PART NUMBER: DS1029-14
- PRODUCT NUMBER CODE:

DS1029-14 - X X X X X X X X X X

- X: PACKING TYPE
T: TRAY
R: TAPE ON REEL
B: TUBE
- X: PICK UP SUPPORT
S: W/ PICK UP
X: W/O PICK UP
- X: BEND TYPE
A: R1 TYPE
B: R2 TYPE
- X: DIM.A B C TYPE
1: TYPE 1
2: TYPE 2
.....
- X: MOUNTING TYPE
V:VERTICAL TYPE
- X: HOUSING COLOR
B:BLACK
- X: CONNECTOR PLATING
6: FULL TIN
- X: CONECT TYPE
P:PLUG
- X: No.OF CONTACTS
1*1-1*20

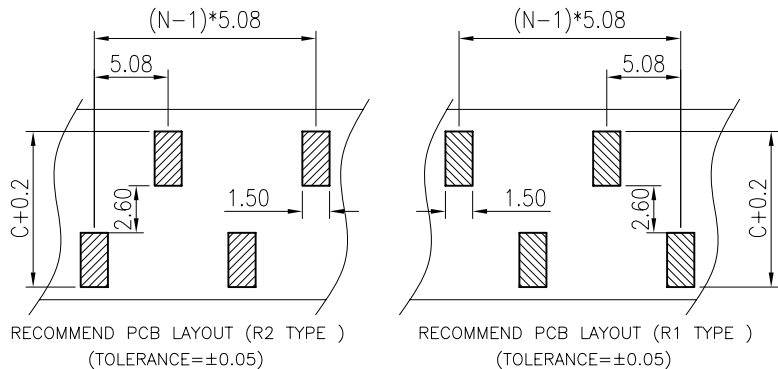

GENERAL TOLERANCE		ANGLE TOLERANCE	
X.	±0.60	X.	±5'
.X	±0.38	.X	±3'
.XX	±0.25	.XX	±2'
DRAWING TYPE		CUSTOMER	
SCALE		1:1	SHEET 1 OF 2
DRAWING NO.		C-DS1029-14-XXXXXXXXXX	

PROJECTION		TITLE	SINGLE ROW DUAL HOUSING PIN HEADER
UNITS	mm		PITCH 5.08mm SMT TYPE
SHEET SIZE	A4	SERIES	DS1029-14 SERIES

晨翔电子有限公司
CONNFLY CONNFLY ELECTRONIC CO. LTD