

CIRCUIT DIAGRAM

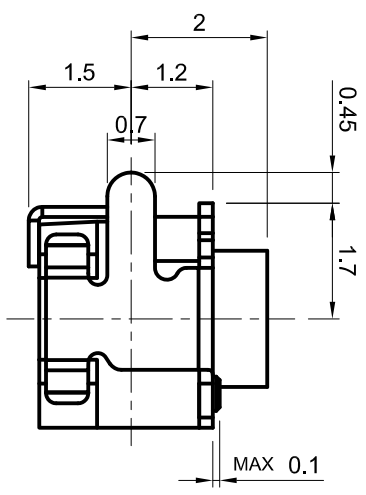

SMD REFLOW PATTERN
(TOLERANCE : ±0.05)

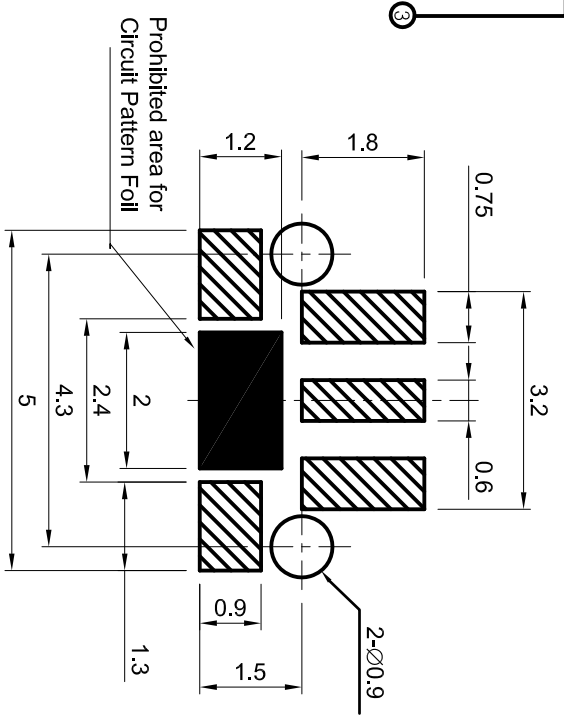

SPECIFICATION

1. RATING : 50mA, DC12V MAX.
2. CIRCUIT : 1C-1P
3. OPERATING FORCE : 160 ±50gf
4. CONTACT RESISTANCE : 100mΩ MAX.
5. TRAVEL : 0.2 ±0.1mm
6. OPERATING LIFE : 100000 CYCLES MIN.
7. TOLERANCE : ± 0.2

		GENERAL TOLERANCE (UNLESS SPECIFIED)		SCALE		UNIT		TITLE	
		±0.2		9/11		METRIC		1133	
		THIRD ANGLE PROJECTION		SIZE		DOCUMENT NUMBER			
		DRAWN BY		CHECKED BY		APPROVED BY		SUNGSAN ENTERPRISE, LTD.	
REV	DESCRIPTION								