

MODEL NO	"L"
1109S	3.8
1109SA	7.0

CIRCUIT DIAGRAM

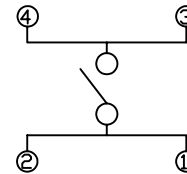

P.C.B LAND DIMENSIONS

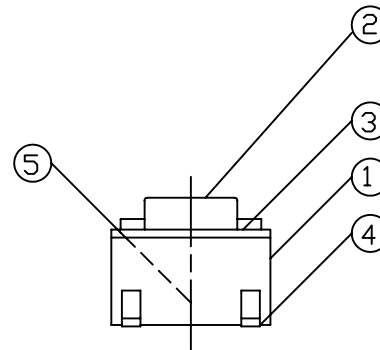
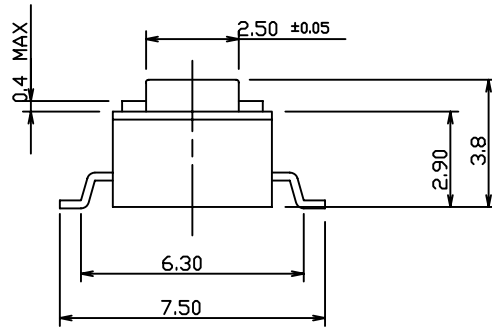
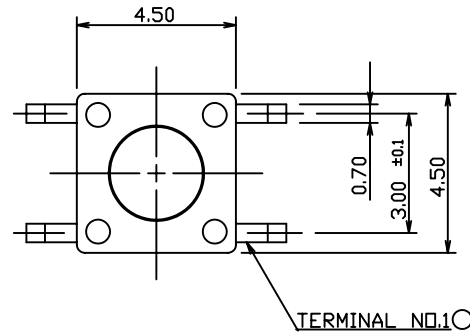
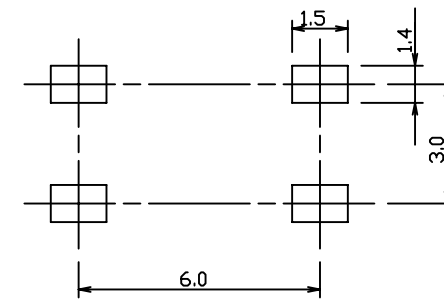

1. OPERATING FORCE :
2. TRAVEL : 0.25 +0.2/-0.1 mm
3. CONTACT RESISTANCE : 100mΩ Max
4. GENERAL TOLERANCE : ±0.3

NO	PART NAME	Q'TY	MATERIAL	REMARK
1	CASE	1	NYLON46	
2	STEM	1	NYLON46	
3	COVER	1	SPTe	Sn 3μ
4	TERMINAL	1	C2680R-EH	Ag 0.5μ
5	CONTACT	1	SUS	Ag 0.5μ

No.	PART NAME	Q'TY	MATERIAL	S I Z E	TREAT.	REMARKS
△			3RD ANGLE PROJECTION	UNIT	SCALE	MODEL
△			APPROVED	m/n	DESIGNED	1109S
△			CHECKED			DWG.NAME
△			SIGN			ASS'Y DIAGRAM
△						DWG.NO.
NO.	DATE	NOTE	SIGN			