

CIRCUIT DIAGRAM

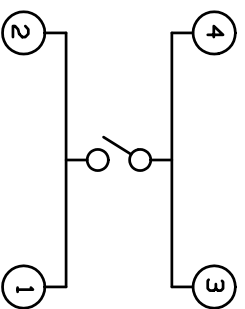

P.C.B DIMENSION

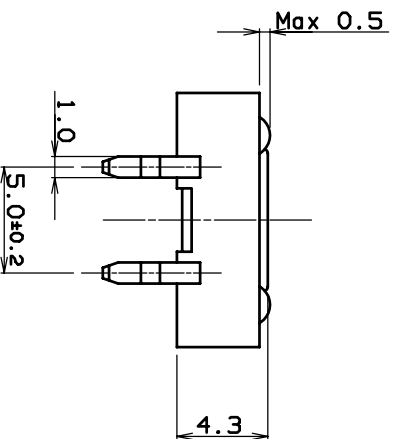
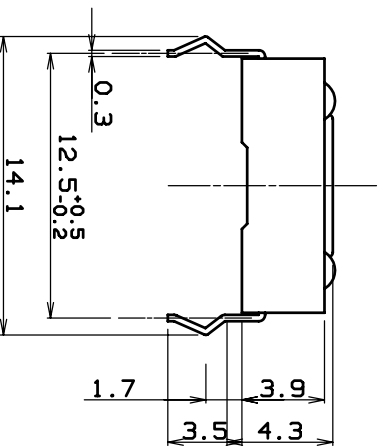
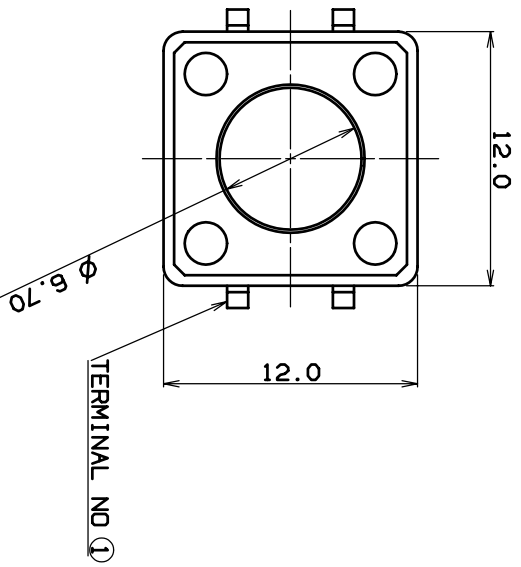
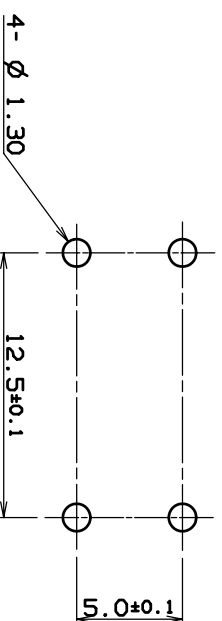

NOTE

1. RATING : DC 12V, 50mA
2. CONTACT RESISTANCE: 100ma Max
3. OPERATING FORCE: 160±50gf
4. TRAVEL : 0.3±0.15 mm
5. GENERAL TOLERANCE: ±0.3

NO	PART NAME	Q'TY	MATERIAL	REMARK
1	COVER	1	PET FILM	
2	STEM	1	NYLON 66	BLACK
3	CASE	1	NYLON 66	BLACK
4	TERMINAL	1	C2680R-EH	Ag0.5μ
5	CONTACT	1	CS210R-EH	Ag 0.5μ

No.	PART NAME	Q'TY	MATERIAL	SCALE	MODEL	TREAT.	REMARKS
△					1103		
△							
△							
△							
△							
△							
△							
△							
△							
△							
NO.	DATE	NOTE	SIGN		DWG. NAME		
					ASS'Y DIAGRAM		
					DWG. NO.		