

CIRCUIT DIAGRAM

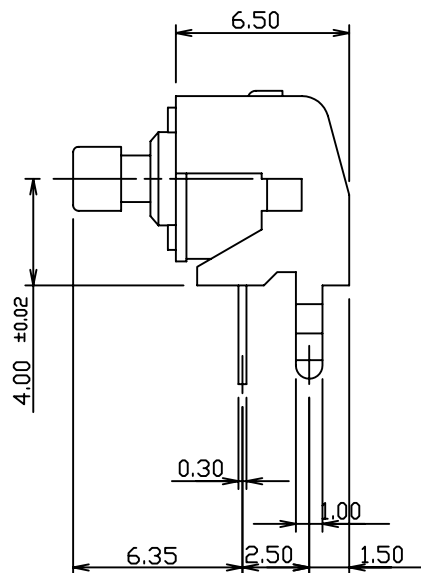

P.C.B DIMENSION

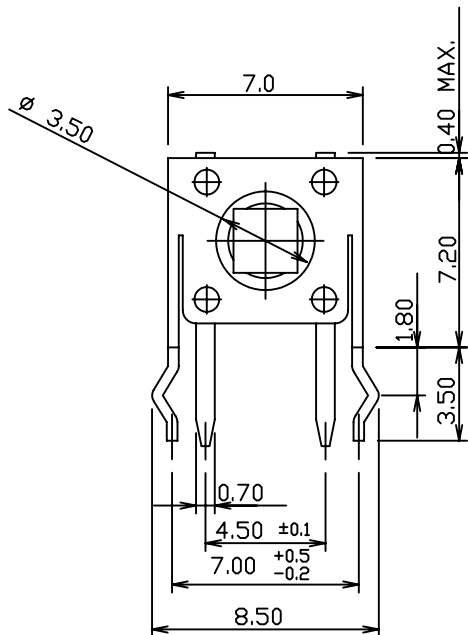
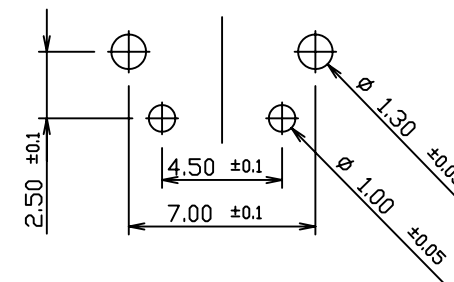

NOTE

1. OPERATING FORCE : 160 ± 50 gf
2. TRAVEL : 0.25 +0.2/-0.1 mm
3. CONTACT RESISTANCE : 100mΩ Max
4. GENERAL TOLERANCE : ±0.3

NO	PART NAME	Q'TY	MATERIAL	RAMARKS
①	CASE	1	NYLON66 G30	BLACK
②	STEM	1	PBT	BLUE
③	BRACKET	1	SPTe	
④	TERMINAL	1	C2680R-EH	Ag0.5μ
⑤	CONTACT	1	C5210R-EH Ag clad 0.5μ	

No.	PART NAME	Q'TY	MATERIAL	SIZE	TREAT.	REMARKS
△			3RD ANGLE PROJECTION	UNIT m/m	SCALE	MODEL 1102NT
△			APPROVED	CHECKED	DESIGNED	DWG.NAME ASS'Y DIAGRAM
△						DWG.NO.
NO.	DATE	NOTE	SIGN			