

CIRCUIT DIAGRAM

P.C.B DIMENSION

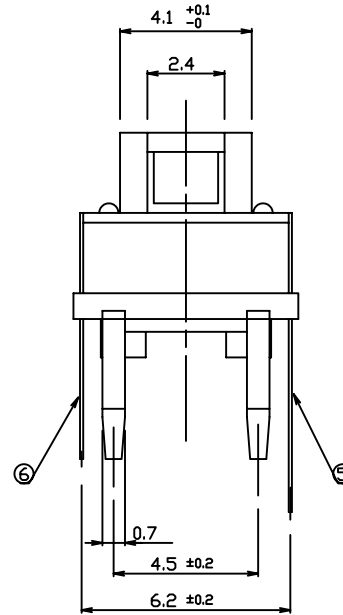
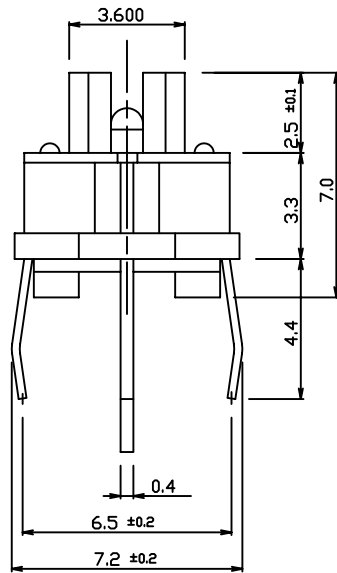
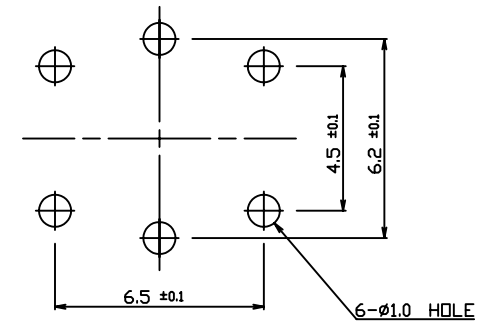
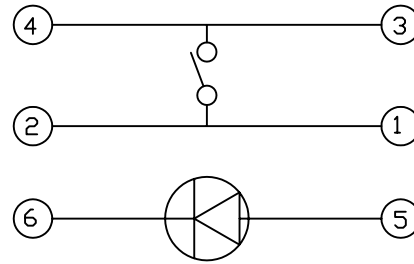
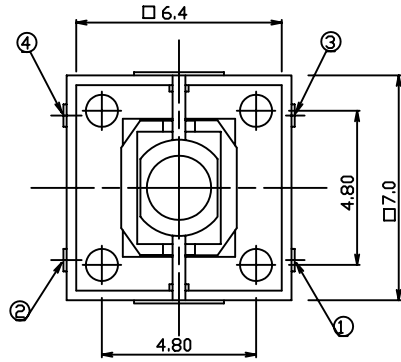

NOTE

- 1.CONTACT : MECHANICAL CONTACT
- 2.RATING : DC 12V 50mA
- 3.TRAVEL : 0.25 mm
- 4.OPERATING FORCE : 160 30gf
- 5.CONTACT RESISTANCE : 100mΩ MAX
- 6.LIFE : 10,000 CYCLES MIN
- 7. WITH LED : OPTION

MODEL NO.	COLOR (LED)
1194R	RED
1194G	GREEN
1194Y	YELLOW

No.	PART NAME	Q'TY	MATERIAL	S I Z E	TREAT.	REMARKS
			UNIT	SCALE	MODEL 1194 SERIES	
			m/m	1	DWG.NAME ASS'Y DIAGRAM	
			APPROVED	CHECKED	DESIGNED	DWG.NO.
NO.	DATE	NOTE	SIGN			