

REV.	DESCRIPTION	DRAWN	CHECKED	APPROVED
A	NEW RELEASE	LL 11/13/06'		

NOTES:

1. SPECIFICATIONS:

- 1.0 CONTACT RESISTANCE: 30mΩ max.
- 1.1 INSULATOR RESISTANCE: 1000MΩ min. AT DC 500V.
- 1.2 CURRENT RATING: 1.5A.
- 1.3 VOLTAGE RATING: 30V AC/DC.
- 1.4 DIELECTRIC STRENGTH: AC 500V FOR 1 Minute.

2. MATERIALS:

- 2.0 HOUSING: PBT+30% GLASS FIBER(UL 94-0).
- 2.1 CONTACT: COPPER ALLOY
- 2.2 SHELL: COPPER ALLOY.

3. PRODUCT NUMBER CODE:

DS1095-X X X X

- CONTACT PLATING
 - 0: Selective gold flash
 - 03: Selective gold 3u"
 - 30: Selective gold 30u"
- MOUNTING TYPE
 - R: R/A
- SHELL PLATING:
 - N: Nickel
 - 6: Tin
- COLOR OF HOUSING:
 - W: WHITE
 - B: Black
- SERIES No.
 - DS1095

GENERAL TOLERANCE		ANGLE TOLERANCE	
X.	±0.60	X.	±5'
.X	±0.38	.X	±3'
.XX	±0.25	.XX	±2'

PROJECTION	TITLE
	USB A TYPE Single port Female TYPE
UNITS	mm
SHEET SIZE	A4
SERIES	DS1095 SERIES

DRAWING TYPE	CUSTOMER
SCALE	1:1 SHEET 1 OF 1
DRAWING NO.	C-DS1095-XXRX

晨翔电子有限公司
CONNFLY CONNFLY ELECTRONIC CO. LTD

REV.	DESCRIPTION	DRAWN	CHECKED	APPROVED
A	NEW RELEASE	LJC 12/20/07'		

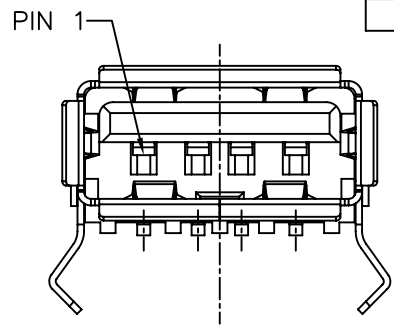
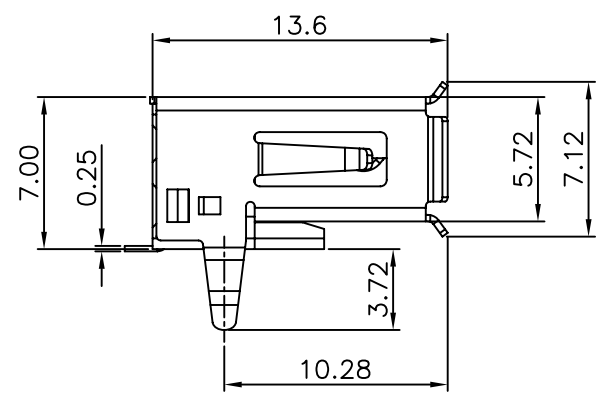

- NOTES:
- SPECIFICATIONS:
 - 1.0 CONTACT RESISTANCE: 30mΩ max.
 - 1.1 INSULATOR RESISTANCE: 1000MΩ min.AT DC 500V.
 - 1.2 CURRENT RATING: 1.5A.
 - 1.3 VOLTAGE RATING: 30V AC/DC.
 - 1.4 DIELECTRIC STRENGTH: AC 500V FOR 1 Minute.
 - MATERIALS:
 - 2.0 HOUSING: PBT+30% GLASS FIBER(UL 94-0).
 - 2.1 CONTACT: COPPER ALLOY
 - 2.2 SHELL: COPPER ALLOY.
 - PRODUCT NUMBER CODE:

DS1095-X X X X

- CONTACT PLATING
 - 0: Selective gold flash
 - 03: Selective gold 3u"
 - 30: Selective gold 30u"
- MOUNTING TYPE
 - M: SMT
- SHELL PLATING:
 - N: Nickel
 - 6: Tin
- COLOR OF HOUSING:
 - W: WHITE
 - B: Black
- SERIES No. DS1095

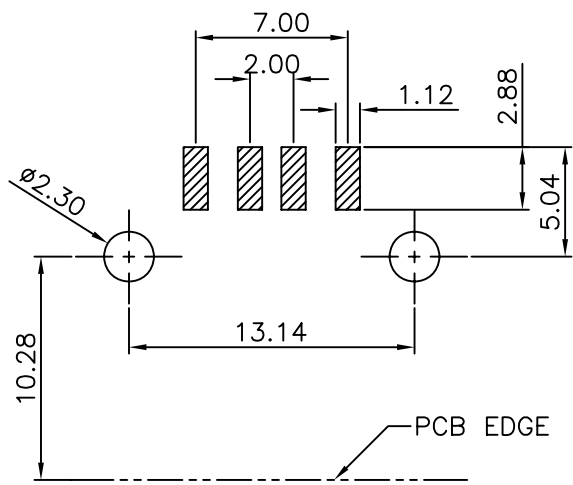
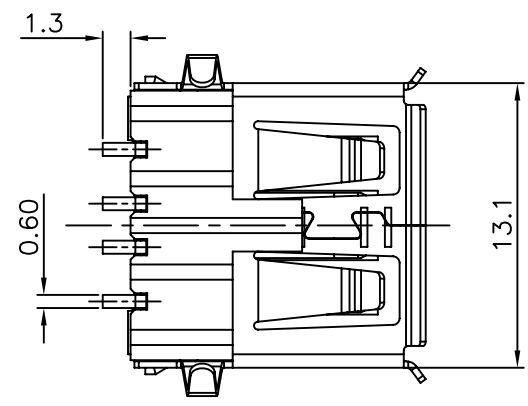

RECOMMEND PCB LAYOUT
(TOLERANCE=±0.05)

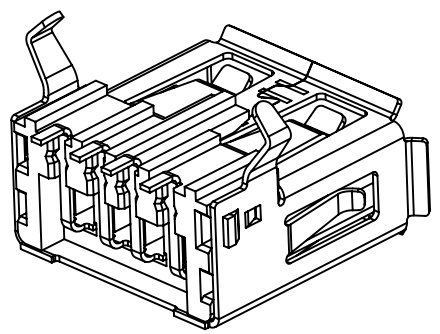

GENERAL TOLERANCE	ANGLE TOLERANCE	PROJECTION	TITLE	USB Female A TYPE
X. ±0.60	X. ±5°	UNITS	mm	SMT series
.X ±0.38	.X ±3°	SHEET SIZE	A4	SERIES DS1095 SERIES
.XX ±0.25	.XX ±2°	 晨翔电子有限公司 CONNPLY ELECTRONIC CO. LTD		
DRAWING TYPE	CUSTOMER			
SCALE	1:1 SHEET 1 OF 1			
DRAWING NO.	C-DS1095-XXMX			

REV.	DESCRIPTION	DRAWN	CHECKED	APPROVED
A	NEW RELEASE	LJC 01/19/09'		

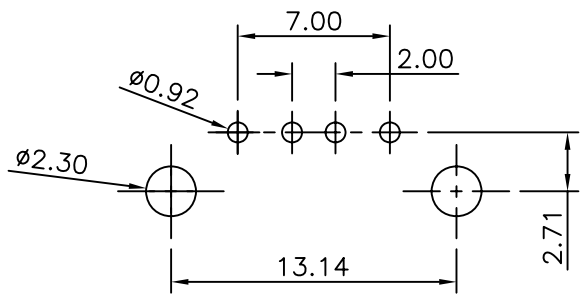
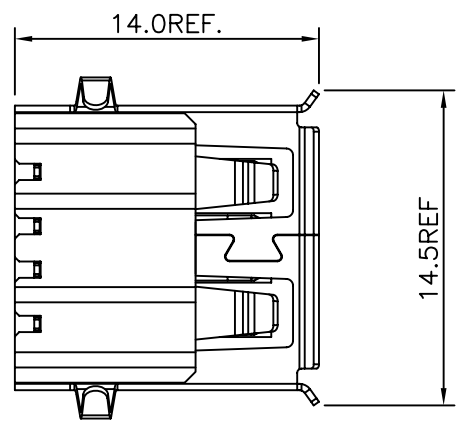
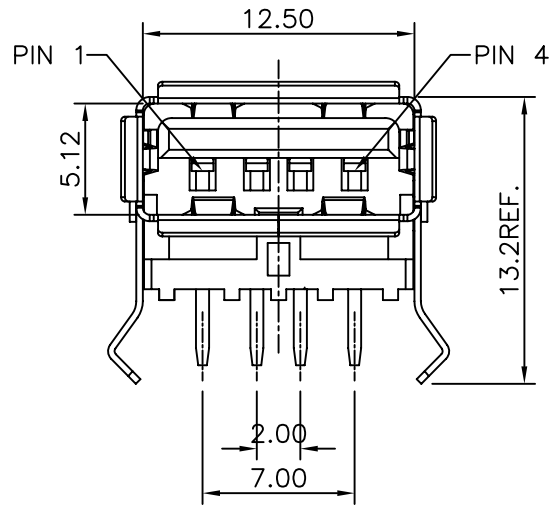
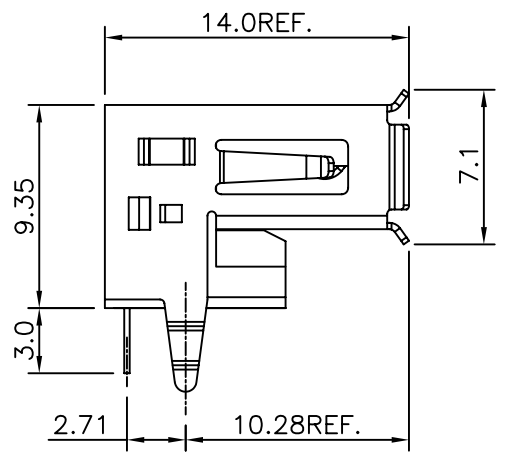

- NOTES:
- SPECIFICATIONS:
 - 1.0 CONTACT RESISTANCE: 30mΩ max.
 - 1.1 INSULATOR RESISTANCE: 1000MΩ min. AT DC 500V.
 - 1.2 CURRENT RATING: 1.5A.
 - 1.3 VOLTAGE RATING: 30V AC/DC.
 - 1.4 DIELECTRIC STRENGTH: AC 500V FOR 1 Minute.
 - MATERIALS:
 - 2.0 HOUSING: PBT+30% GLASS FIBER(UL 94-0).
 - 2.1 CONTACT: COPPER ALLOY
 - 2.2 SHELL: COPPER ALLOY.
 - PRODUCT NUMBER CODE:

DS1095-03-X X X X

- CONTACT PLATING
 - 0: Selective gold flash
 - 03: Selective gold 3u"
 - 30: Selective gold 30u"
- MOUNTING TYPE
 - R: R/A
- SHELL PLATING:
 - N: Nickel
 - 6: Tin
- COLOR OF HOUSING:
 - W: WHITE
 - B: Black

GENERAL TOLERANCE		ANGLE TOLERANCE		PROJECTION		TITLE	USB A TYPE FEMALE		
X.	±0.60	X.	±5°	UNITS	mm		R/A H=9.35mm		
.X	±0.38	.X	±3°	SHEET SIZE	A4	SERIES	DS1095-03 SERIES		
.XX	±0.25	.XX	±2°						
DRAWING TYPE		CUSTOMER			晨翔电子有限公司 CONNFLY CONNFLY ELECTRONIC CO. LTD				
SCALE		1:1	SHEET 1 OF 1						
DRAWING NO.		C-DS1095-03-XXXX							

REV.	DESCRIPTION	DRAWN	CHECKED	APPROVED
A	NEW RELEASE	YCH 06/20/12'	~	

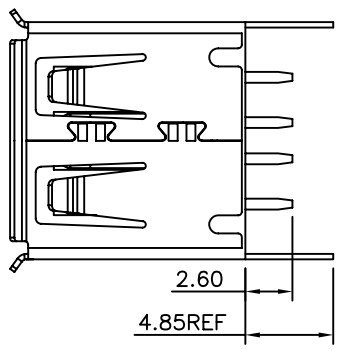
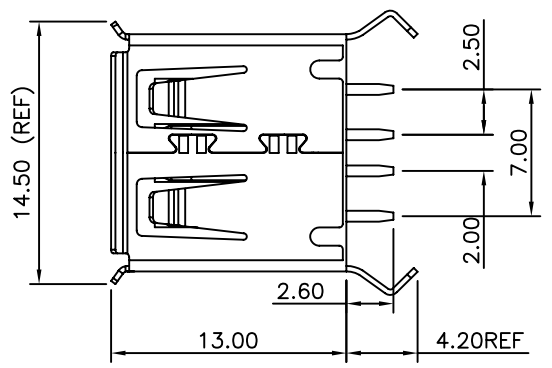
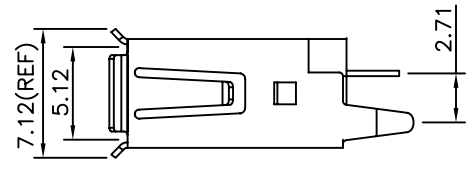
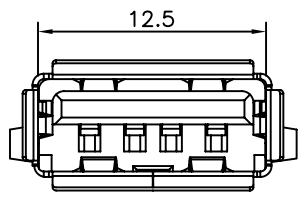

BEND TYPE →

STRAIGHT TYPE →

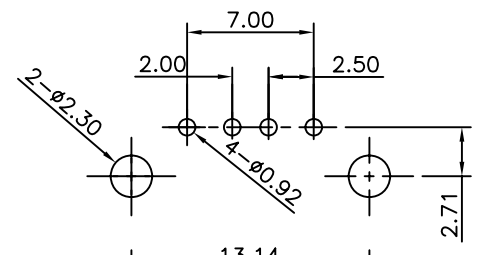

RECOMMEND PCB LAYOUT
(TOLERANCE=±0.05)

NOTES:

- SPECIFICATIONS:
 - CONTACT RESISTANCE: 30mΩ max.
 - INSULATOR RESISTANCE: 1000MΩ min.AT DC 500V.
 - CURRENT RATING: 1.5A.
 - VOLTAGE RATING: 30V AC/DC.
 - DIELECTRIC STRENGTH: AC 500V FOR 1 Minute.
- MATERIALS:
 - HOUSING: PBT+30% GLASS FIBER(UL 94-0).
 - CONTACT: COPPER ALLOY
 - SHELL: COPPER ALLOY.
- PRODUCT NUMBER CODE:

DS1095-08-X X X X

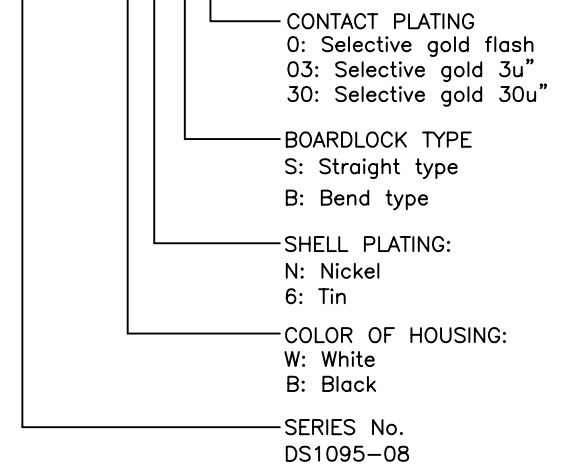

GENERAL TOLERANCE		ANGLE TOLERANCE	
X.	±0.60	X.	±5'
.X	±0.38	.X	±3'
.XX	±0.25	.XX	±2'

DRAWING TYPE	CUSTOMER		
SCALE	1:1	SHEET	1 OF 1
DRAWING NO.	C-DS1095-08-XXXX		

PROJECTION		TITLE	USB A/F180' TYPE Single port Female TYPE
UNITS	mm	SHEET	1 OF 1
SHEET SIZE	A4	SERIES	DS1095-08 SERIES

晨翔电子有限公司
CONNFLY CONNFLY ELECTRONIC CO. LTD

REV.	DESCRIPTION	DRAWN	CHECKED	APPROVED
A	NEW RELEASE	YCH 06/20/12'	~	

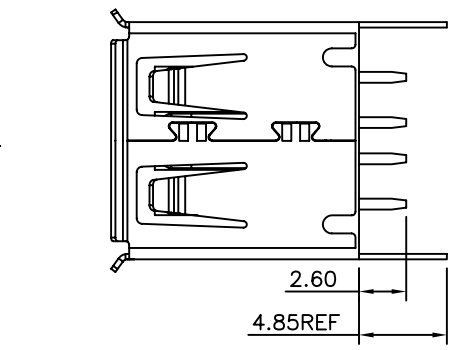
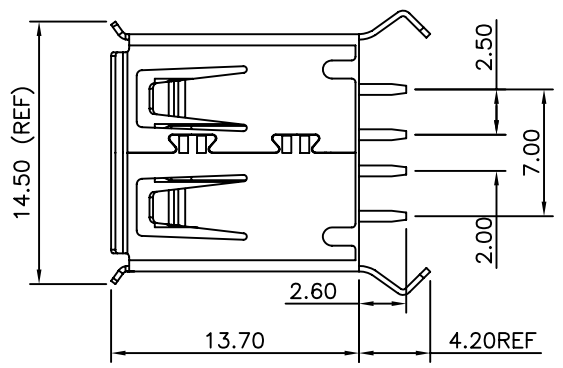
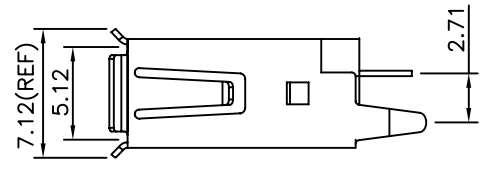
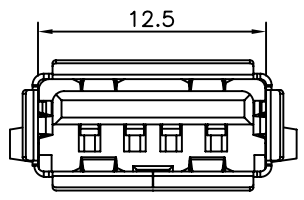

BEND TYPE →

STRAIGHT TYPE →

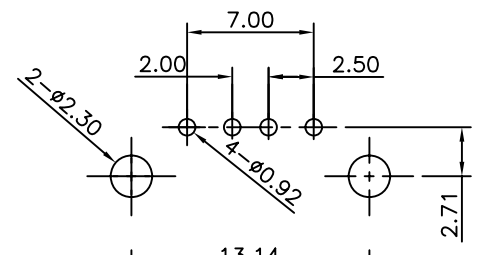

RECOMMEND PCB LAYOUT
(TOLERANCE=±0.05)

NOTES:

- SPECIFICATIONS:
 - CONTACT RESISTANCE: 30mΩ max.
 - INSULATOR RESISTANCE: 1000MΩ min.AT DC 500V.
 - CURRENT RATING: 1.5A.
 - VOLTAGE RATING: 30V AC/DC.
 - DIELECTRIC STRENGTH: AC 500V FOR 1 Minute.
- MATERIALS:
 - HOUSING: PBT+30% GLASS FIBER(UL 94-0).
 - CONTACT: COPPER ALLOY
 - SHELL: COPPER ALLOY.
- PRODUCT NUMBER CODE:

DS1095-09-X X X X

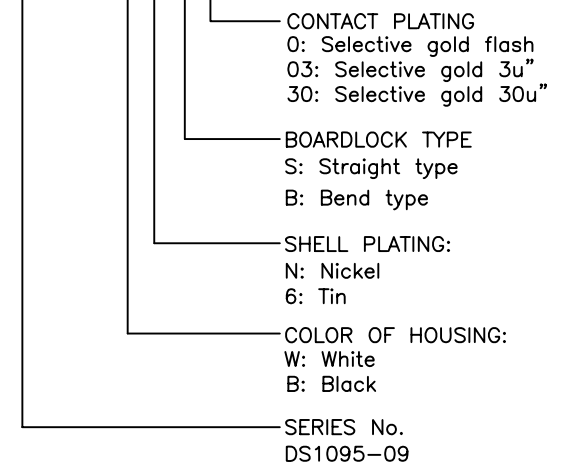

GENERAL TOLERANCE		ANGLE TOLERANCE	
X.	±0.60	X.	±5'
.X	±0.38	.X	±3'
.XX	±0.25	.XX	±2'
DRAWING TYPE		CUSTOMER	
SCALE		1:1	SHEET 1 OF 1
DRAWING NO.		C-DS1095-09-XXXX	

PROJECTION		TITLE	USB A/F180' TYPE Single port Female TYPE
UNITS	mm	SHEET SIZE	A4
SHEET SIZE	A4	SERIES	DS1095-09 SERIES

晨翔电子有限公司
CONNFLY CONNFLY ELECTRONIC CO. LTD

REV.	DESCRIPTION	DRAWN	CHECKED	APPROVED
A	NEW RELEASE	YCH 06/20/12'	~	

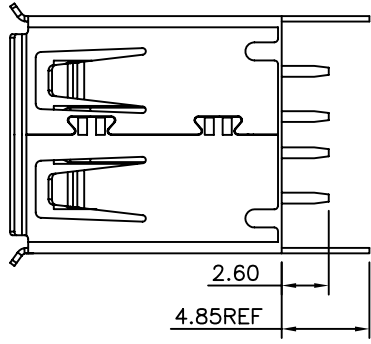
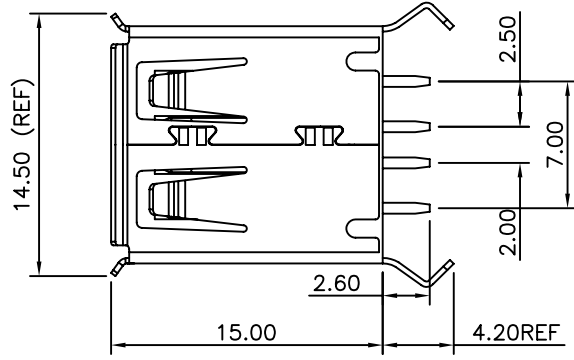
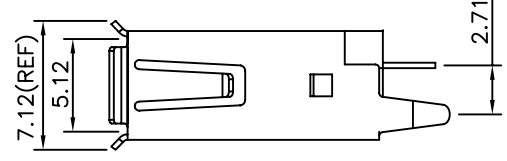
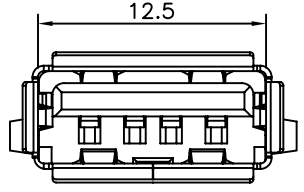

BEND TYPE →

STRAIGHT TYPE →

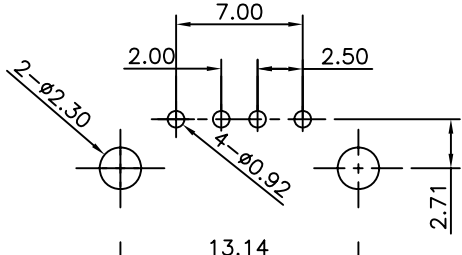

RECOMMEND PCB LAYOUT
(TOLERANCE=±0.05)

NOTES:

- SPECIFICATIONS:
 - CONTACT RESISTANCE: 30mΩ max.
 - INSULATOR RESISTANCE: 1000MΩ min.AT DC 500V.
 - CURRENT RATING: 1.5A.
 - VOLTAGE RATING: 30V AC/DC.
 - DIELECTRIC STRENGTH: AC 500V FOR 1 Minute.
- MATERIALS:
 - HOUSING: PBT+30% GLASS FIBER(UL 94-0).
 - CONTACT: COPPER ALLOY
 - SHELL: COPPER ALLOY.
- PRODUCT NUMBER CODE:

DS1095-10-X X X X

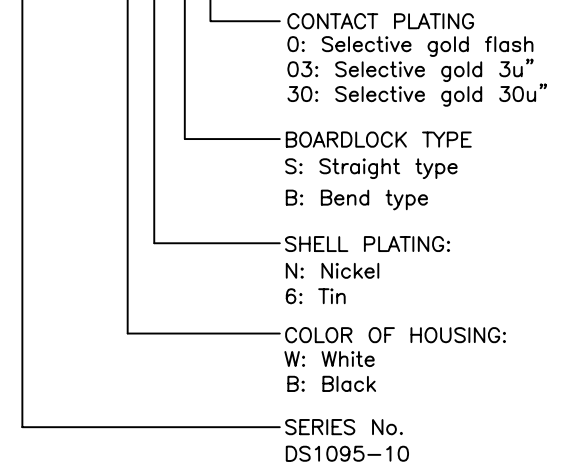

GENERAL TOLERANCE		ANGLE TOLERANCE	
X.	±0.60	X.	±5'
.X	±0.38	.X	±3'
.XX	±0.25	.XX	±2'

DRAWING TYPE	CUSTOMER		
SCALE	1:1	SHEET	1 OF 1
DRAWING NO.	C-DS1095-10-XXXX		

PROJECTION		TITLE	USB A/F180' TYPE Single port Female TYPE
UNITS	mm	SHEET SIZE	A4
SHEET SIZE	A4	SERIES	DS1095-10 SERIES

晨翔电子有限公司
CONNFLY CONNFLY ELECTRONIC CO. LTD

REV.	DESCRIPTION	DRAWN	CHECKED	APPROVED
A	NEW RELEASE	YCH 08/09/08'		

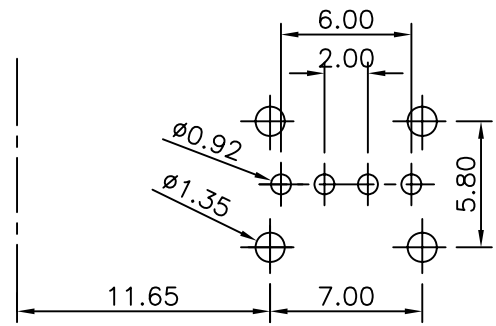
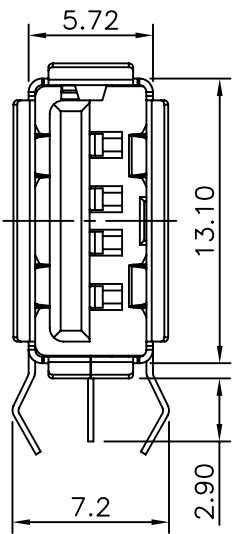
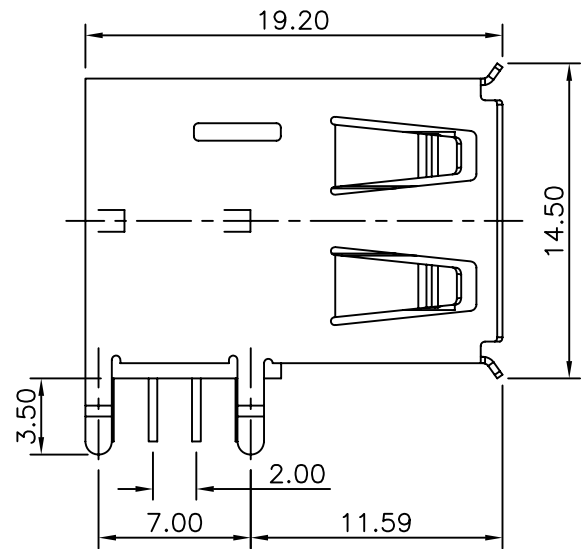
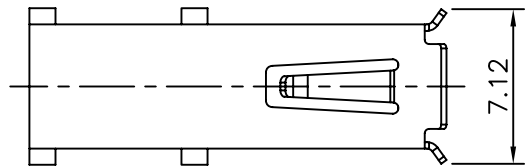

RECOMMEND PCB LAYOUT
(TOLERANCE= ± 0.05)

NOTES:

- SPECIFICATIONS:
 - CONTACT RESISTANCE: 30m Ω max.
 - INSULATOR RESISTANCE: 1000M Ω min. AT DC 500V.
 - CURRENT RATING: 1.5A.
 - VOLTAGE RATING: 30V AC/DC.
 - DIELECTRIC STRENGTH: AC 500V FOR 1 Minute.
 - TEMPERATURE RANGE: -40°C ~ +105°C .

- MATERIALS:
 - HOUSING: PBT+30% GLASS FIBER(UL 94-0).
 - CONTACT: COPPER ALLOY
 - SHELL: COPPER ALLOY.

3. PRODUCT NUMBER CODE:

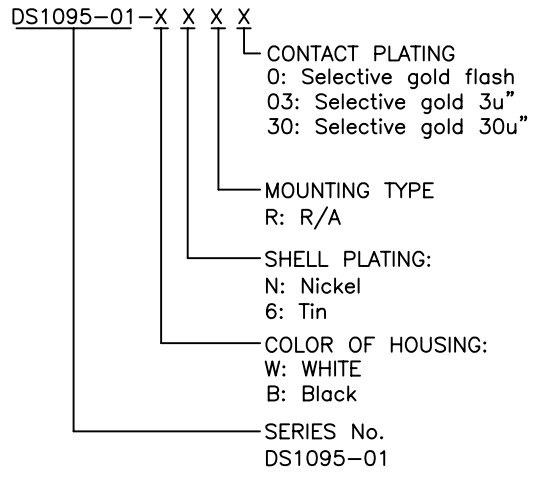

GENERAL TOLERANCE		ANGLE TOLERANCE		PROJECTION		TITLE	USB A TYPE UP RIGHT ANGLE TYPE	
X.	± 0.60	X.	$\pm 5^\circ$	UNITS	mm			
.X	± 0.38	.X	$\pm 3^\circ$	SHEET SIZE	A4	SERIES	DS1095-01 SERIES	
.XX	± 0.25	.XX	$\pm 2^\circ$	晨翔电子有限公司 CONNFLY CONNFLY ELECTRONIC CO. LTD				
DRAWING TYPE		CUSTOMER						
SCALE	1:1	SHEET	1 OF 1					
DRAWING NO.		C-DS1095-01-XXRX						

REV.	DESCRIPTION	DRAWN	CHECKED	APPROVED
A	NEW RELEASE	YCH 05/08/08'	~	

NOTES:

1. SPECIFICATIONS:

- 1.0 CONTACT RESISTANCE:30mΩ max.
- 1.1 INSULATION RESISTANCE:1000MΩ min.
- 1.2 CURRENT RATING:1.5A.
- 1.3 VOLTAGE RATING:30VDC.
- 1.4 DIELECTRIC WITHSTANDING VOLTAGE:AC 500V FOR 1 Minute.
- 1.5 TEMPERATURE RANGE: -45°C ~ +110°C.

2. MATERIALS:

- 2.0 HOUSING:PBT+30% GLASS FIBER(UL 94-0).
- 2.1 CONTACT:COPPER ALLOY
- 2.2 SHELL:COPPER ALLOY.

3. PRODUCT NUMBER CODE:

DS1099-01 - X X X

- CONTACT PLATING
- 0: Selective Gold Flash
- 03: Selective Gold 3u"
- 30: Selective Gold 30u"
- SHELL PLATING
- N: Nickel
- 6: Tin
- COLOR OF HOUSING:
- W: WHITE
- B: BLACK
- SERIES No.
- DS1099-01 series

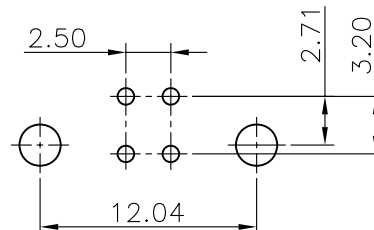
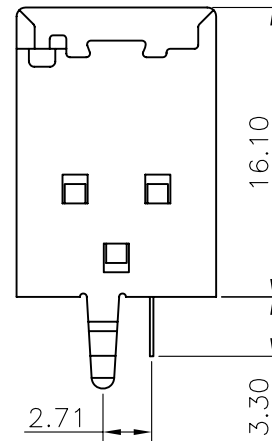
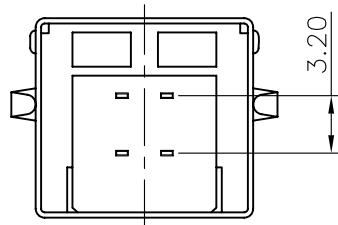
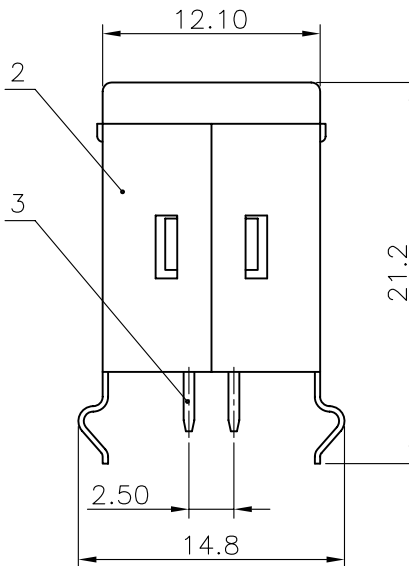
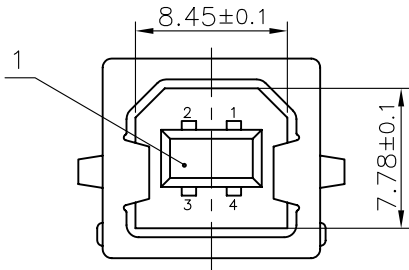

RECOMMEND PCB LAYOUT
TOLERANCE=±0.05

GENERAL TOLERANCE		ANGLE TOLERANCE	
X.	±0.60	X.	±5°
.X	±0.38	.X	±3°
.XX	±0.25	.XX	±2°

PROJECTION	TITLE
UNITS	USB B TYPE FEMALE V/T DIP TYPE
SHEET SIZE	SERIES DS1099-01 SERIES

ITEM	PART NAME	PART NO.	MATERILAS	FINISHED
3	CONTACT		COPPER ALLOY	SEE NOTES
2	SHELL		COPPER ALLOY	SEE NOTES
1	HOUSING		PBT	UL 94 V-0

DRAWING TYPE	CUSTOMER
SCALE	1:1 SHEET 1 OF 1
DRAWING NO.	C-DS1099-01-XXX

 晨翔电子有限公司
CONNFLY CONNFLY ELECTRONIC CO. LTD

REV.	DESCRIPTION	DRAWN	CHECKED	APPROVED
A	NEW RELEASE	LJC 12/20/07'		

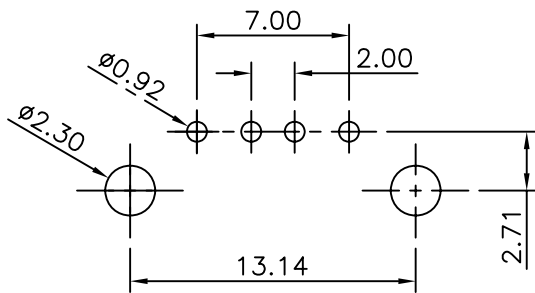
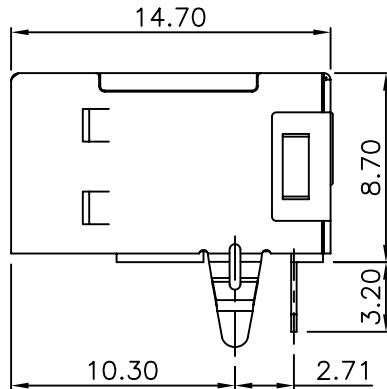
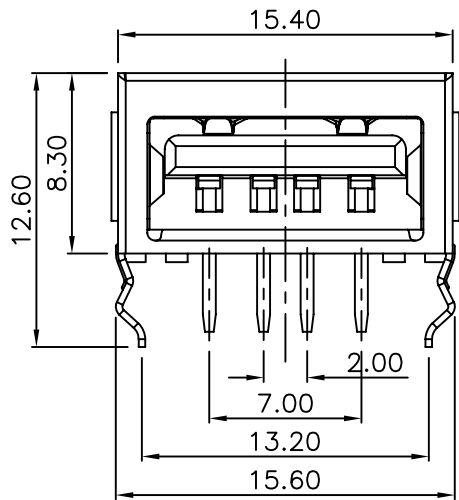
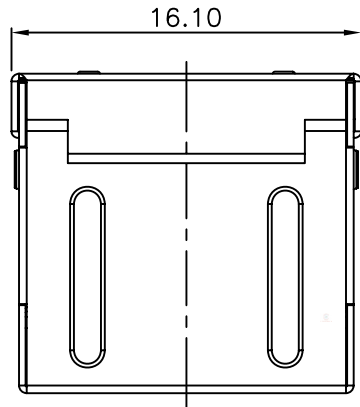

RECOMMEND PCB LAYOUT
(TOLERANCE=±0.05)

NOTES:

1. SPECIFICATIONS:

- 1.0 CONTACT RESISTANCE: 30mΩ max.
- 1.1 INSULATOR RESISTANCE: 1000MΩ min.AT DC 500V.
- 1.2 CURRENT RATING: 1.5A.
- 1.3 VOLTAGE RATING: 30V AC/DC.
- 1.4 DIELECTRIC STRENGTH: AC 500V FOR 1 Minute.

2. MATERIALS:

- 2.0 HOUSING: PBT+30% GLASS FIBER(UL 94-0).
- 2.1 CONTACT: COPPER ALLOY
- 2.2 SHELL: COPPER ALLOY.

3. PRODUCT NUMBER CODE:

DS1095-04-X X X X

CONTACT PLATING

- 0: Selective gold flash
- 03: Selective gold 3u"
- 30: Selective gold 30u"

MOUNTING TYPE

R: R/A

SHELL PLATING:

- N: Nickel
- 6: Tin

COLOR OF HOUSING:

- W: White
- B: Black

SERIES No.

DS1095-04

GENERAL TOLERANCE		ANGLE TOLERANCE		PROJECTION		TITLE	USB Female A TYPE	
X.	±0.60	X.	±5°	UNITS	mm		R/A Anti-EMI series	
.X	±0.38	.X	±3°	SHEET SIZE	A4	SERIES	DS1095-04 SERIES	
.XX	±0.25	.XX	±2°			晨翔电子有限公司 CONNFLY CONNFLY ELECTRONIC CO. LTD		
DRAWING TYPE		CUSTOMER						
SCALE	1:1	SHEET	1 OF 1					
DRAWING NO.		C-DS1095-04-XXXX						

REV.	DESCRIPTION	DRAWN	CHECKED	APPROVED
A	NEW RELEASE	YCH 08/30/08'	~	

NOTES:

1. SPECIFICATIONS:

- 1.0 CONTACT RESISTANCE: 30mΩ max.
- 1.1 INSULATOR RESISTANCE: 1000MΩ min.AT DC 500V.
- 1.2 CURRENT RATING: 1.5A.
- 1.3 VOLTAGE RATING: 30V AC/DC.
- 1.4 DIELECTRIC STRENGTH: AC 500V FOR 1 Minute.
- 1.5 TEMPERATURE RANGE: -45°C ~ +110°C.

2. MATERIALS:

- 2.0 HOUSING: PBT+30% GLASS FIBER(UL 94-0).
- 2.1 CONTACT: COPPER ALLOY
- 2.2 SHELL: COPPER ALLOY.

3. PRODUCT NUMBER CODE:

DS1095-02-X X X X

- CONTACT PLATING
 - 0: Selective gold flash
 - 03: Selective gold 3u"
 - 30: Selective gold 30u"
- MOUNTING TYPE
 - M: SMT
- SHELL PLATING:
 - N: Nickel
 - 6: Tin
- COLOR OF HOUSING:
 - W: White
 - B: Black
- SERIES No. DS1095-02

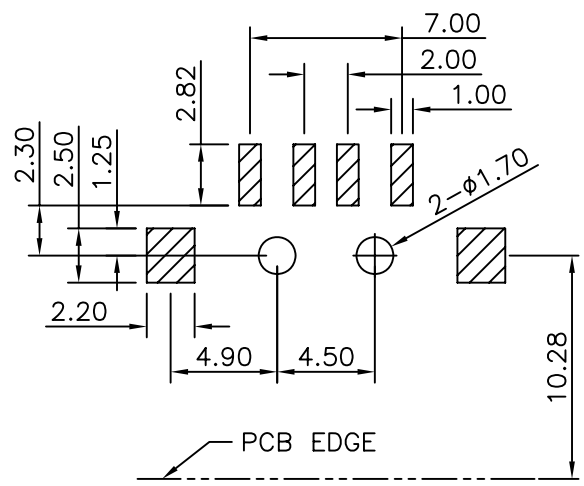
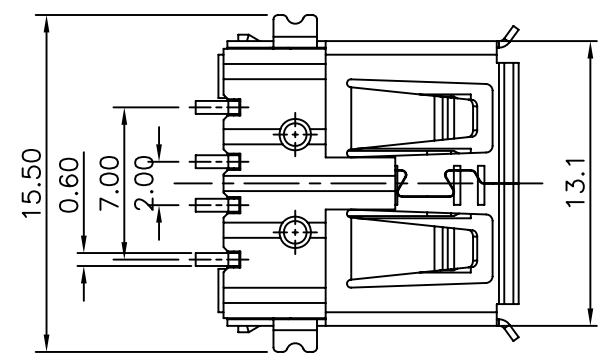
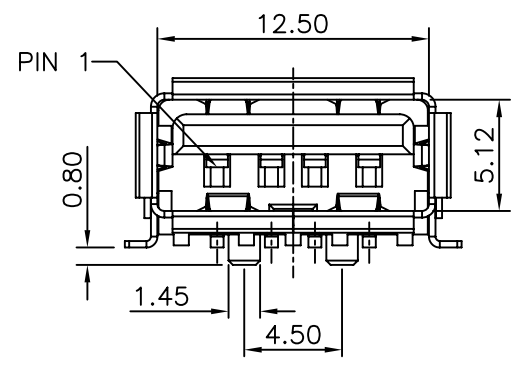
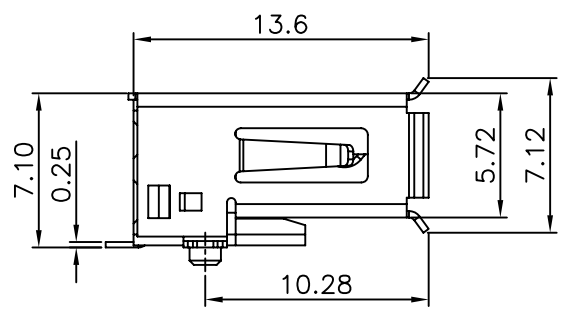

RECOMMEND PCB LAYOUT
(TOLERANCE=±0.05)

GENERAL TOLERANCE		ANGLE TOLERANCE		PROJECTION		TITLE	USB FEMALE A TYPE SMT SERIES	
X.	±0.60	X.	±5°	UNITS	mm			
.X	±0.38	.X	±3°	SHEET SIZE	A4	SERIES	DS1095-02 SERIES	
.XX	±0.25	.XX	±2°	晨翔电子有限公司 CONNFLY CONNFLY ELECTRONIC CO. LTD				
DRAWING TYPE		CUSTOMER						
SCALE		1:1 SHEET 1 OF 1						
DRAWING NO.		C-DS1095-02-XXMX						

REV.	DESCRIPTION	DRAWN	CHECKED	APPROVED
A	NEW RELEASE	LJH 05/10/05'		

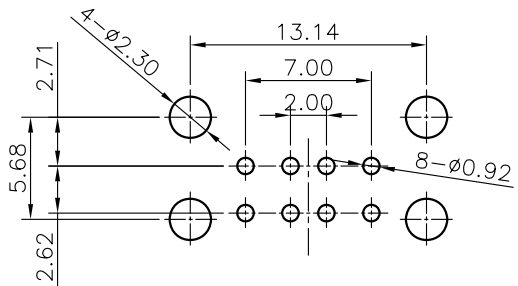
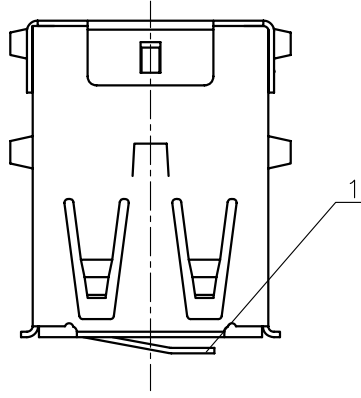

NOTES:

- SPECIFICATIONS:
 - CONTACT RESISTANCE:30mΩ max.
 - INSULATOR RESISTANCE:1000MΩ min.AT DC 500V.
 - CURRENT RATING:1.5A.
 - VOLTAGE RATING:30VDC.
 - DIELECTRIC STRENGTH:AC 500V FOR 1 Minute.
- MATERIALS:
 - HOUSING:PBT+30% GLASS FIBER(UL 94-0).
 - CONTACT:COPPER ALLOY
 - SHELL:COPPER ALLOY.
- PRODUCT NUMBER CODE:
- PRODUCT NUMBER CODE:

DS1096 - X X X

- CONTACT Plating
 - 0: Selective Gold flash
 - 03: Selective Gold 3u"
 - 30: Selective Gold 30u"
- SHELL Plating
 - N: Nickel
 - 6: Tin
- COLOR OF HOUSING:
 - W: WHITE
 - B: BLACK
- PRODUCTS SERIES:
 - DS1096 series

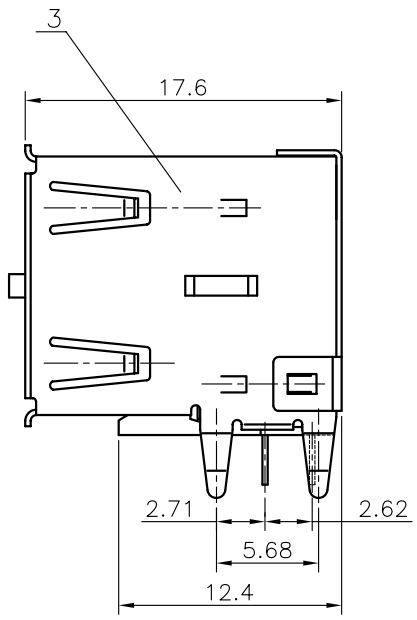
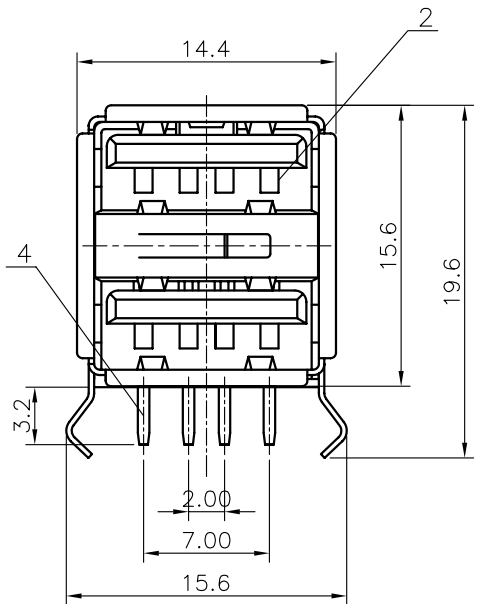

GENERAL TOLERANCE				ANGLE TOLERANCE		PROJECTION	TITLE
X.	±0.60	X.	±5°	UNITS	mm	USB DUAL 8 PIN RECEPTALCE RIGHT ANGLE TYPE	
.X	±0.38	.X	±3°	SHEET SIZE	A4	SERIES	DS1096 SERIES
.XX	±0.25	.XX	±2°	DRAWING TYPE CUSTOMER			
4	CONTACT	COPPER ALLOY	SEE NOTES	SCALE	1:1	SHEET	1 OF 1
3	SHELL	COPPER ALLOY	SEE NOTES	DRAWING NO.	C-DS1096-XXX		
2	HOUSING	PBT	UL 94 V-0				
1	SPRING CLIP	COPPER ALLOY	Nickel Plated				
ITEM	PART NAME	PART NO.	MATERILAS	FINISHED			

		晨翔电子有限公司 CONNFLY ELECTRONIC CO. LTD	
--	--	--	--

REV.	DESCRIPTION	DRAWN	CHECKED	APPROVED
A	NEW RELEASE	HP 21/06/05		

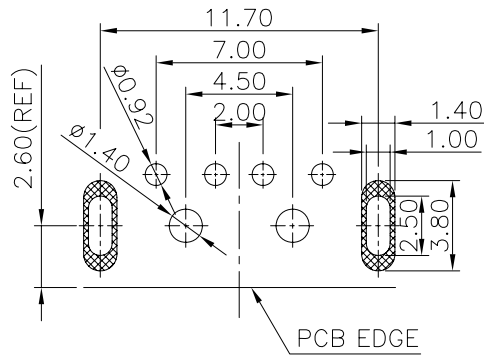
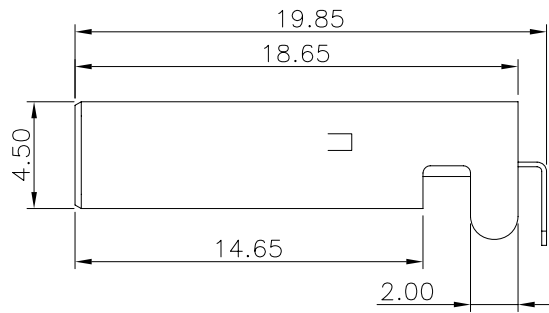
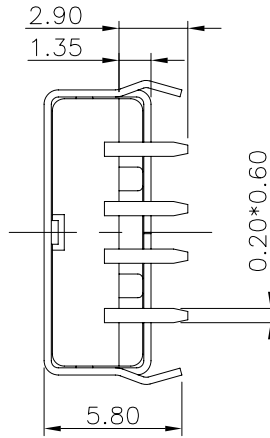
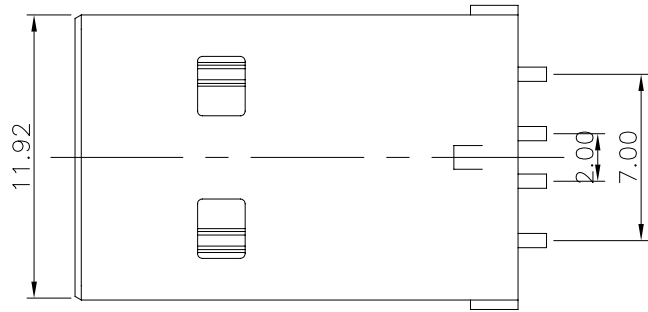

NOTES:

- SPECIFICATIONS:
 - CONTACT RESISTANCE:30mΩ max.
 - INSULATION RESISTANCE:1000MΩ min.
 - CURRENT RATING:1.5A.
 - VOLTAGE RATING:30VDC.
 - DIELECTRIC WITHSTANDING VOLTAGE:AC 500V FOR 1 Minute.

- MATERIALS:
 - HOUSING:THERMOPLASTIC(UL 94 V-0).
 - CONTACT:COPPER ALLOY
 - SHELL:STEEL

3. PRODUCT NUMBER CODE:

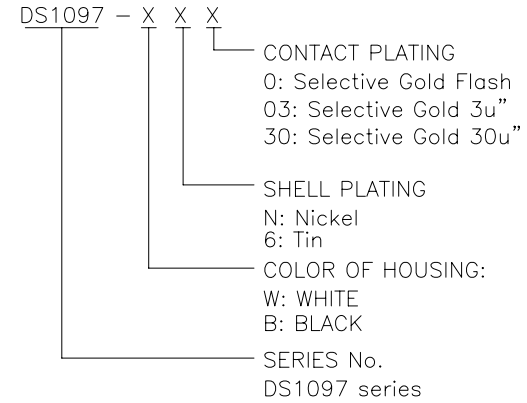

RECOMMEND PCB LAYOUT(TOLERANCE±0.05)

GENERAL TOLERANCE		ANGLE TOLERANCE		PROJECTION		TITLE	USB A TYPE, MALE RIGHT ANGLE TYPE		
X.	±0.60	X.	±5°	UNITS	mm				
.X	±0.38	.X	±3°	SHEET SIZE	A4	SERIES	DS1097		
.XX	±0.25	.XX	±2°	晨翔电子有限公司 CONNFLY CONNFLY ELECTRONIC CO. LTD					
DRAWING TYPE		CUSTOMER							
SCALE		1:1	SHEET 1 OF 1						
DRAWING NO.		C-DS1097-XXX							

REV.	DESCRIPTION	DRAWN	CHECKED	APPROVED
A	NEW RELEASE	LJH 07/28/05'		

NOTES:

1. SPECIFICATIONS:

- 1.0 VOLTAGE RATING: 30V DC.
- 1.1 CONTACT CURRENT RATING: 1.5A MAX. PER PIN.
- 1.2 CONTACT RESISTANCE: 30 mΩ MAX.
- 1.3 DIELECTRIC WITHSTANDING VOLTAGE:
500V AC FOR 1 MINUTE.
- 1.4 INSULATION RESISTANCE: 1000MΩ MIN.
- 1.5 OPERATING TEMPERATURE: -40°C ~ +105°C.

2. PRODUCT NUMBER CODE:

DS1107 - X X X

CONTACT PLATED:

- 0: Selective Gold Flash
- C: 3u" Gold
- 3: 30u" Gold

SHELL PLATED:

- N: Nickel
- 6: Tin

COLOR OF HOUSING:

- W: WHITE
- B: BLACK

PRODUCTS SERIES:

DS1107

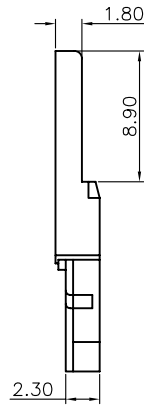
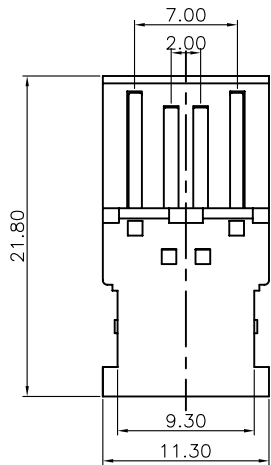
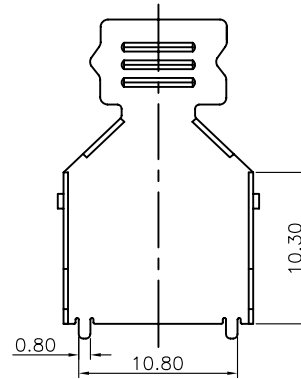
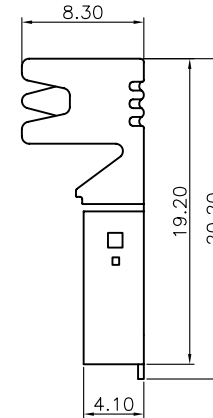
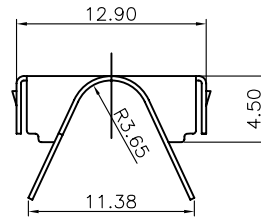

Housing with contact

Upper shell

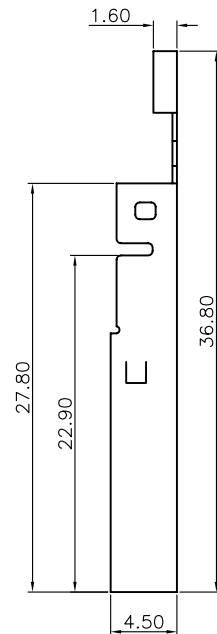
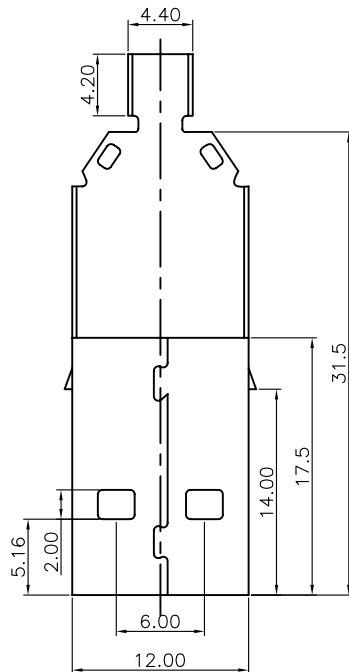

Down shell

GENERAL TOLERANCE		ANGLE TOLERANCE	
X.	±0.60	X.	±5°
.X	±0.38	.X	±3°
.XX	±0.25	.XX	±2°

PROJECTION		TITLE	USB PLUG A TYPE SOLDER TYPE
UNITS	mm	SHEET	1 OF 1
SHEET SIZE	A4	SERIES	DS1107

DRAWING TYPE	CUSTOMER		
SCALE	1:1	SHEET	1 OF 1
DRAWING NO.	C-DS1107-XXX		

 **晨翔电子有限公司**
CONNFLY CONNFLY ELECTRONIC CO. LTD

REV.	DESCRIPTION	DRAWN	CHECKED	APPROVED
A	NEW RELEASE	HP 23/06/05		

NOTES:

1. SPECIFICATIONS

- . Contact Resistance: 30mΩ max
- . Insulator Resistance: 1000MΩ min.
- . Current Rating: 30V DC 1.5 A max
- . Dielectric withstanding voltage: AC500V For 1 minute
- . Contact: Copper alloy
- . Housing: PBT.

2. PRODUCT NUMBER CODE:

DS1108 - X X X

- Contact plating
 - 0: selective gold flash
 - C 3u" gold
 - 3: 30u" gold
- Shell plating
 - 6: tin
 - N: nickel
 - 8: full gold
- Color of housing
 - W: white
 - B: black

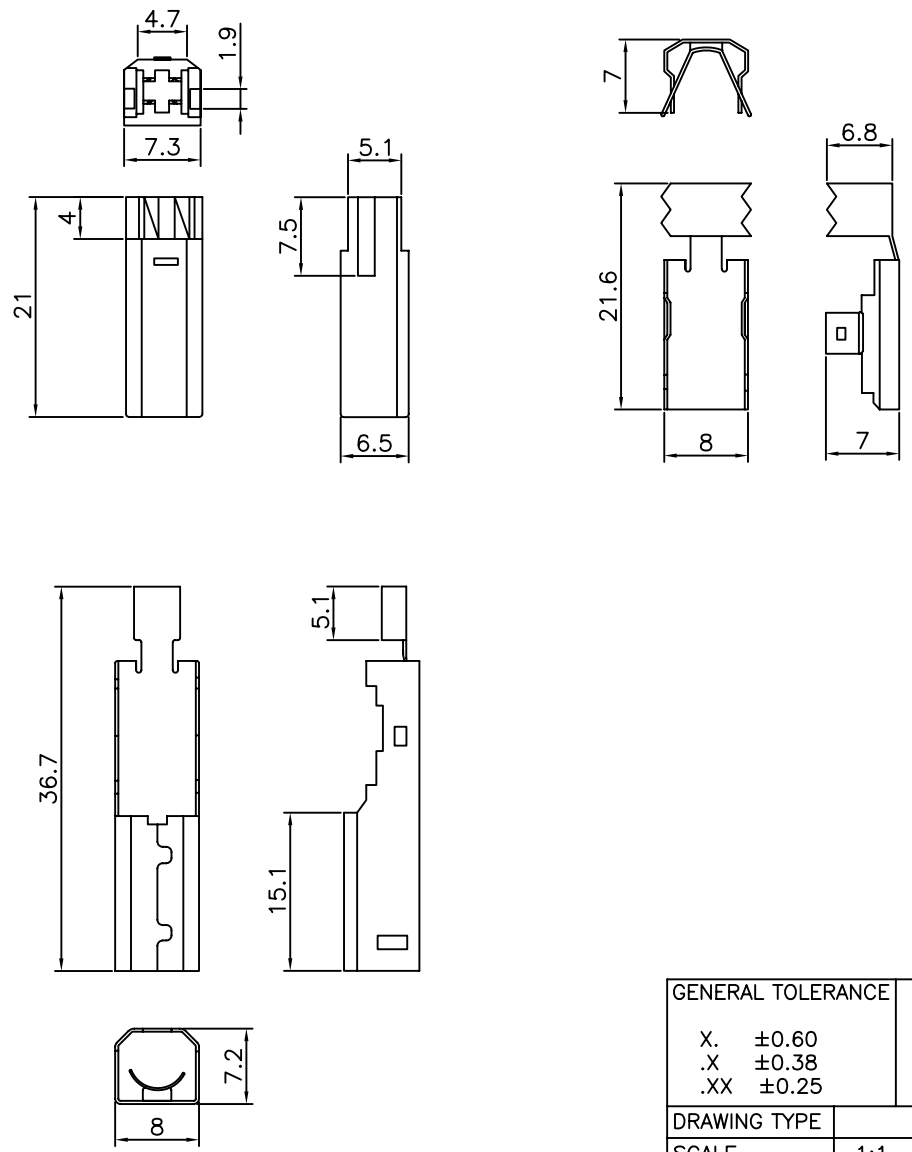

GENERAL TOLERANCE		ANGLE TOLERANCE		PROJECTION		TITLE	USB-B MALE SOLDER	
X.	±0.60	X.	±5°	UNITS	mm			
.X	±0.38	.X	±3°	SHEET SIZE	A4	SERIES	DS1108	
.XX	±0.25	.XX	±2°	晨翔电子有限公司 CONNFLY ELECTRONIC CO. LTD				
DRAWING TYPE		CUSTOMER						
SCALE		1:1	SHEET 1 OF 1					
DRAWING NO.		C-DS1108-XXX						

REV.	DESCRIPTION	DRAWN	CHECKED	APPROVED
A	NEW RELEASE	LJH 05/10/05'		

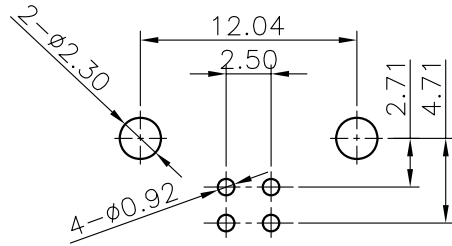
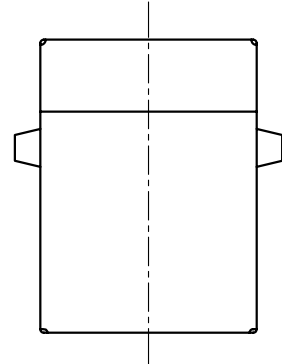

RECOMMEND PCB LAYOUT
TOLERANCE=±0.05

NOTES:

- SPECIFICATIONS:
 - CONTACT RESISTANCE:30mΩ max.
 - INSULATION RESISTANCE:1000MΩ min.
 - CURRENT RATING:1.5A.
 - VOLTAGE RATING:30VDC.
 - DIELECTRIC WITHSTANDING VOLTAGE:AC 500V FOR 1 Minute.

- MATERIALS:
 - HOUSING:PBT+30% GLASS FIBER(UL 94-0).
 - CONTACT:COPPER ALLOY
 - SHELL:COPPER ALLOY.

3. PRODUCT NUMBER CODE:

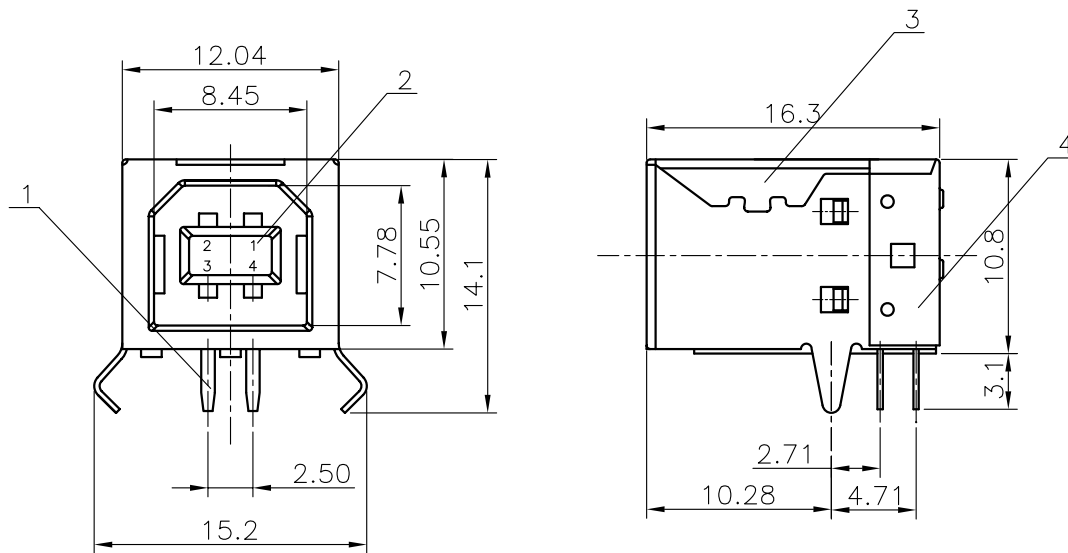
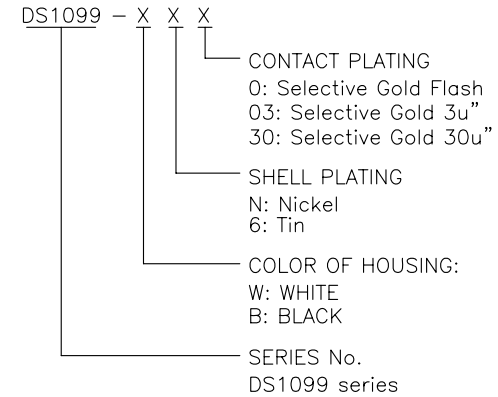

				GENERAL TOLERANCE	ANGLE TOLERANCE	PROJECTION	TITLE	USB B TYPE R/A DIP TYPE	
4	BACK SHELL		COPPER ALLOY	X. ±0.60	X. ±5°	UNITS	mm	SHEET	1 OF 1
3	FRONT SHELL		COPPER ALLOY	.X ±0.38	.X ±3°	SHEET SIZE	A4	SERIES	DS1099 SERIES
2	HOUSING		PBT	.XX ±0.25	.XX ±2°	 晨翔电子有限公司 CONNPLY CONNPLY ELECTRONIC CO. LTD			
1	CONTACT		COPPER ALLOY						
ITEM	PART NAME	PART NO.	MATERILAS	FINISHED	DRAWING NO.	C-DS1099-XXX			

REV.	DESCRIPTION	DRAWN	CHECKED	APPROVED
A	NEW RELEASE	LJH 05/09/05'		

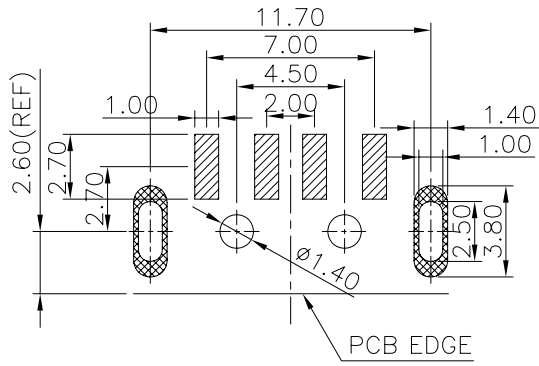
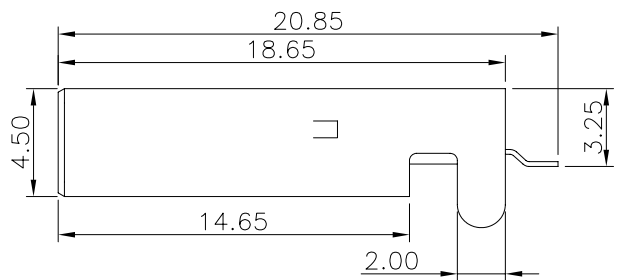
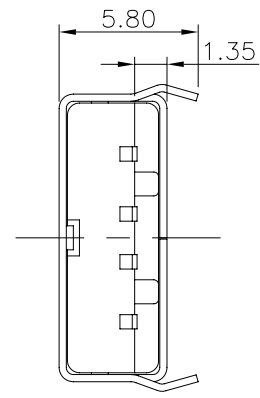
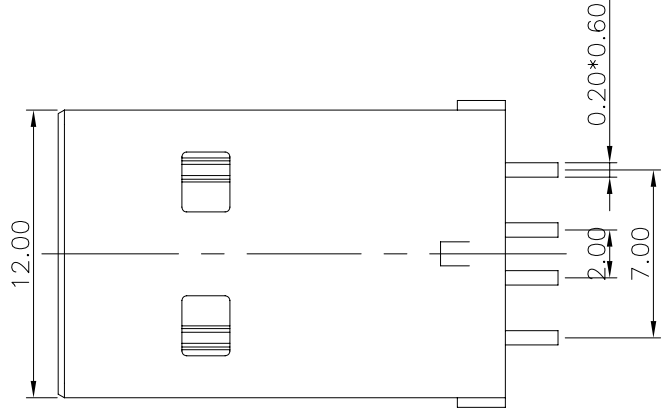

RECOMMEND PCB LAYOUT(TOLERANCE ± 0.05)

NOTES:

- SPECIFICATIONS:
 - CONTACT RESISTANCE:30m Ω max.
 - INSULATION RESISTANCE:1000M Ω min.
 - CURRENT RATING:1.5A.
 - VOLTAGE RATING:30VDC.
 - DIELECTRIC WITHSTANDING VOLTAGE:AC 500V FOR 1 Minute.

- MATERIALS:
 - HOUSING: THERMOPLASTIC (UL 94 V-0).
 - CONTACT:COPPER ALLOY
 - SHELL:STEEL

3. PRODUCT NUMBER CODE:

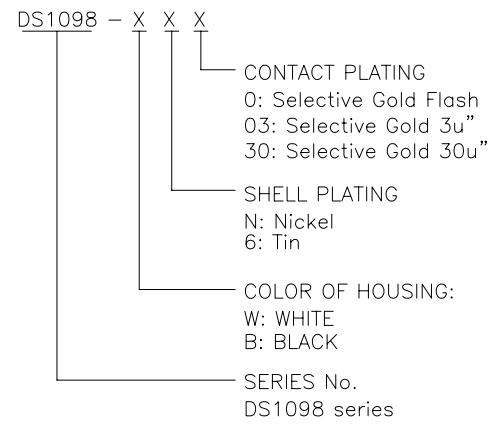

GENERAL TOLERANCE	ANGLE TOLERANCE
X. ± 0.60	X. $\pm 5^\circ$
.X ± 0.38	.X $\pm 3^\circ$
.XX ± 0.25	.XX $\pm 2^\circ$

PROJECTION	TITLE
	USB A TYPE MALE, SMT R/A TYPE
UNITS	mm
SHEET SIZE	A4
SERIES	DS1098

DRAWING TYPE	CUSTOMER
SCALE	1:1 SHEET 1 OF 1
DRAWING NO.	C-DS1098-XXX

晨翔电子有限公司
CONNFLY CONNFLY ELECTRONIC CO. LTD