

REV.	DESCRIPTION	DRAWN	CHECKED	APPROVED
A	NEW RELEASE	DGQ 06/14/11'		

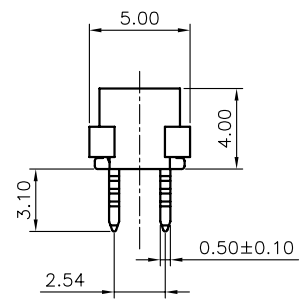
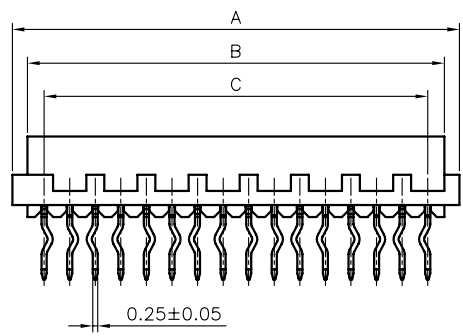
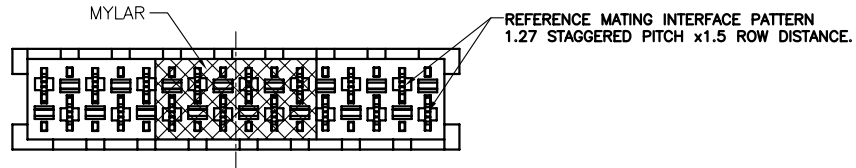

NOTES:

- MATERIAL
 - INSULATOR:THERMOPLASTIC(UL 94V-0).
 - CONTACT: 0.25t COPPER ALLOY.
- SPECIFICATION
 - TEMPERATURE RANGE:-40°C~+105°C.
 - CONTACT RESISTANCE:30mΩ max.
 - INSULATION RESISTANCE:1000MΩ min.
 - DIELECTRIC WITHSTANDING VOLTAGE:AC 500V PER MINUTE.

3. PRODUCT NUMBER CODE:

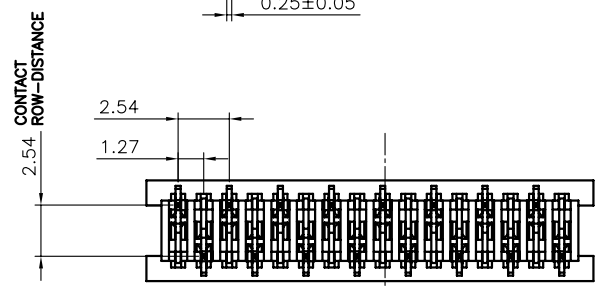
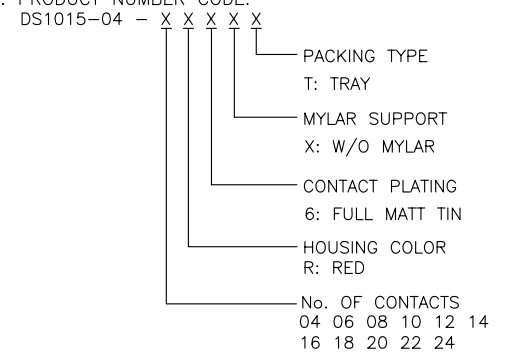

POSITIONS	DIM A	DIM B	DIM C
4	6.96	5.46	3.81
6	9.50	8.00	6.35
8	12.04	10.54	8.89
10	14.58	13.08	11.43
12	17.12	15.62	13.97
14	19.66	18.16	16.51
16	22.20	20.70	19.05
18	24.74	23.24	21.59
20	27.28	25.78	24.13
22	29.82	28.32	26.67
24	32.36	30.86	29.21

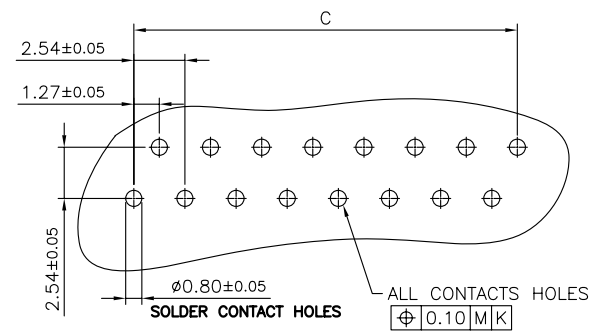
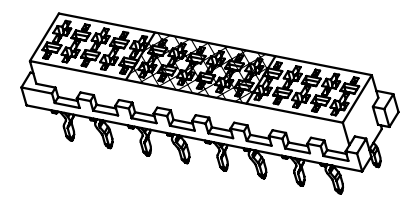

GENERAL TOLERANCE	ANGLE TOLERANCE	PROJECTION	⊕ - ▽	TITLE	MICRO MATCH FEMALE VERTICAL THROUGH HOLE TYPE		
X. ±0.60	X. ±5°	UNITS	mm	SHEET	A4		
.X ±0.38	.X ±3°	SHEET SIZE	A4	SERIES	DS1015-04 SERIES		
.XX ±0.25	.XX ±2°	晨翔电子有限公司 CONNFLY CONNFLY ELECTRONIC CO. LTD					
DRAWING TYPE	CUSTOMER						
SCALE	1:1						SHEET
DRAWING NO.	C-DS1015-04-XXXX-A						

REV.	DESCRIPTION	DRAWN	CHECKED	APPROVED
A	NEW RELEASE	DGQ 06/14/11'		

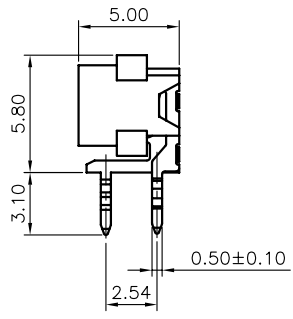
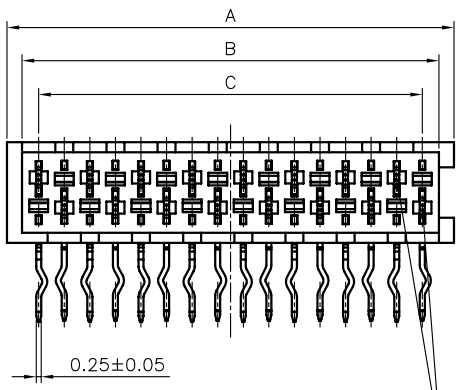

REFERENCE MATING INTERFACE PATTERN
1.27 STAGGERED PITCH x1.5 ROW DISTANCE.

NOTES:

- MATERIAL
 - INSULATOR:THERMOPLASTIC(UL 94V-0).
 - CONTACT: 0.25t COPPER ALLOY.
- SPECIFICATION
 - TEMPERATURE RANGE:-40°C~+105°C.
 - CONTACT RESISTANCE:30mΩ max.
 - INSULATION RESISTANCE:1000MΩ min.
 - DIELECTRIC WITHSTANDING VOLTAGE:AC 500V PER MINUTE.

3. PRODUCT NUMBER CODE:

DS1015-05 - X X X X

- PACKING TYPE
- T: TRAY
- CONTACT PLATING
- 6: FULL MATT TIN
- HOUSING COLOR
- R: RED
- No. OF CONTACTS
- 04 06 08 10 12 14
- 16 18 20 22 24

CONTACT ROW-DISTANCE

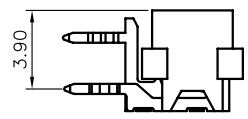
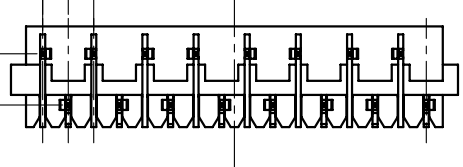
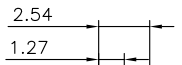

POSITIONS	DIM A	DIM B	DIM C
4	6.96	5.46	3.81
6	9.50	8.00	6.35
8	12.04	10.54	8.89
10	14.58	13.08	11.43
12	17.12	15.62	13.97
14	19.66	18.16	16.51
16	22.20	20.70	19.05
18	24.74	23.24	21.59
20	27.28	25.78	24.13
22	29.82	28.32	26.67
24	32.36	30.86	29.21

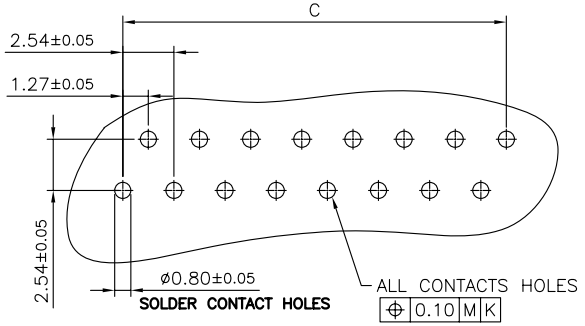
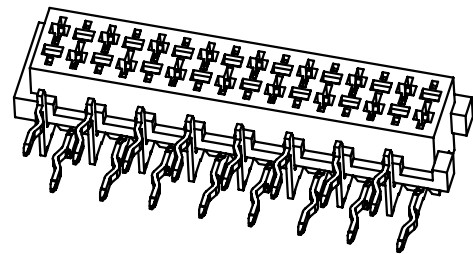

RECOMMEND PCB LAYOUT
(COMPONENT SIDE OF BOARD SHOWN)

GENERAL TOLERANCE	ANGLE TOLERANCE	PROJECTION	TITLE
X. ±0.60	X. ±5°	UNITS	MICRO MATCH FEMALE RIGHT ANGLE THROUGH HOLE TYPE
.X ±0.38	.X ±3°	SHEET SIZE	SERIES DS1015-05 SERIES
.XX ±0.25	.XX ±2°		
DRAWING TYPE	CUSTOMER	晨翔电子有限公司 CONNFly CONNFly ELECTRONIC CO. LTD	
SCALE	1:1 SHEET 1 OF 1		
DRAWING NO.	C-DS1015-05-XXXX-A		

REV.	DESCRIPTION	DRAWN	CHECKED	APPROVED
A	NEW RELEASE	YCH 03/11/11'		

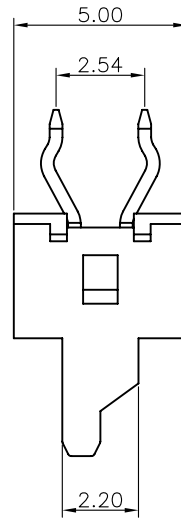
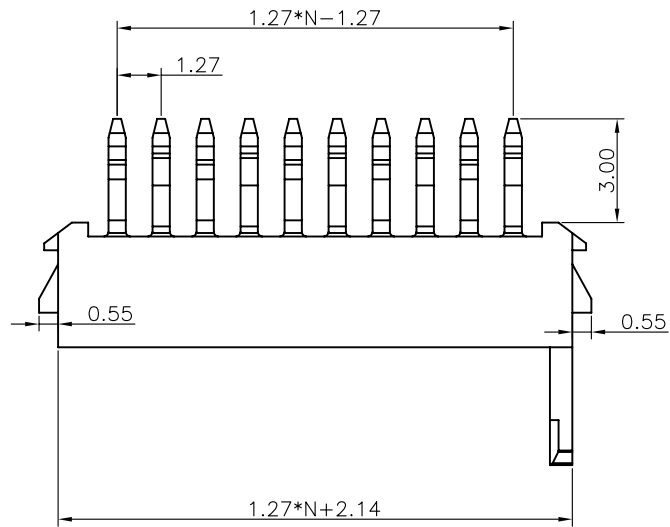

NOTES:

- MATERIAL
 - INSULATOR:THERMOPLASTIC(UL 94V-0).
 - CONTACT: COPPER ALLOY.
- SPECIFICATION
 - TEMPERATURE RANGE:-40°C~+105°C.
 - CONTACT RESISTANCE:30mΩ max.
 - INSULATION RESISTANCE:1000MΩ min.
 - DIELECTRIC WITHSTANDING VOLTAGE:AC 500V PER MINUTE.

3. PRODUCT NUMBER CODE:

DS1015-07- X X X

CONTACT PLATING
 2: NICKEL + GOLD FLASH
 6: Full Tin
 8: Full GOLD FLASH

HOUSING COLOR
 R:RED

No. OF CONTACTS
 04 06 08 10 12
 14 16 18 20 24

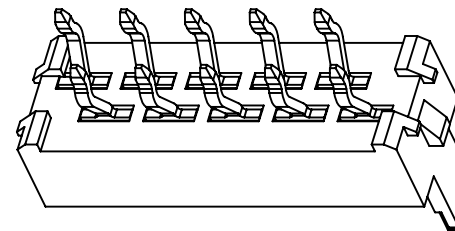
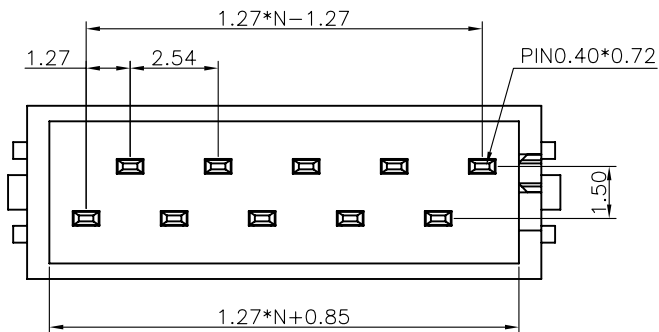

GENERAL TOLERANCE		ANGLE TOLERANCE		PROJECTION		TITLE	RED DIP SERIES	
X.	±0.60	X.	±5°	UNITS	mm		(MICRO MATCH CONNECTOR)	
.X	±0.38	.X	±3°	SHEET SIZE	A4	SERIES	DS1015-07 SERIES	
.XX	±0.25	.XX	±2°	晨翔电子有限公司 CONNFLY CONNFLY ELECTRONIC CO. LTD				
DRAWING TYPE		CUSTOMER						
SCALE	1:1	SHEET	1 OF 1					
DRAWING NO.		C-DS1015-07-XXX						

REV.	DESCRIPTION	DRAWN	CHECKED	APPROVED
A	NEW RELEASE	DGQ 06/14/11'		

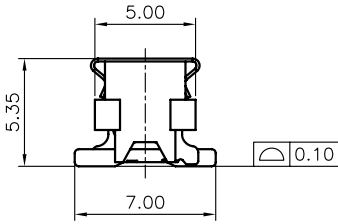
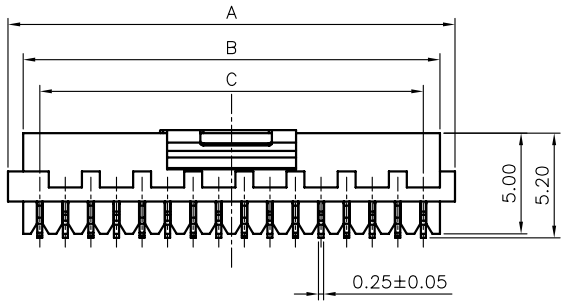
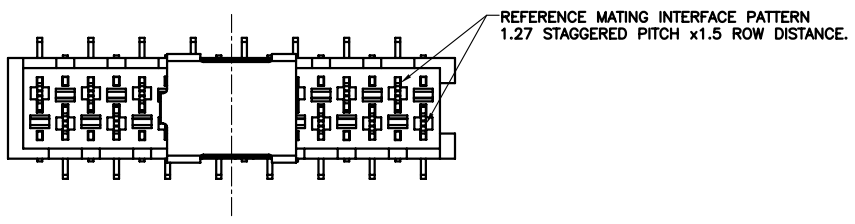

- NOTES:
- MATERIAL
 - INSULATOR:THERMOPLASTIC(UL 94V-0).
 - CONTACT: 0.25t COPPER ALLOY.
 - PICKUP: 0.15t STAINLESS STEEL.
 - SPECIFICATION
 - TEMPERATURE RANGE:-40°C~+105°C.
 - CONTACT RESISTANCE:30mΩ max.
 - INSULATION RESISTANCE:1000MΩ min.
 - DIELECTRIC WITHSTANDING VOLTAGE:AC 500V PER MINUTE.
 - PRODUCT NUMBER CODE:
DS1015-06 - X X X X X

PACKING TYPE
T: TRAY
R: TAPE ON REEL
B: TUBE

PICKUP SUPPORT
X: W/O MYLAR
S: W MYLAR

CONTACT PLATING
6: FULL MATT TIN

HOUSING COLOR
R: RED

No. OF CONTACTS
04 06 08 10 12 14
16 18 20 22 24

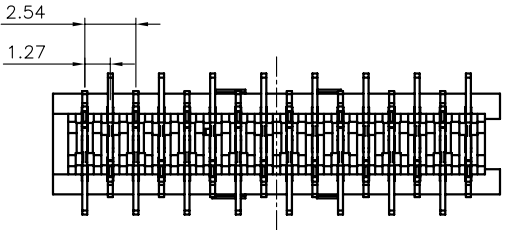

POSITIONS	DIM A	DIM B	DIM C
4	6.96	5.46	3.81
6	9.50	8.00	6.35
8	12.04	10.54	8.89
10	14.58	13.08	11.43
12	17.12	15.62	13.97
14	19.66	18.16	16.51
16	22.20	20.70	19.05
18	24.74	23.24	21.59
20	27.28	25.78	24.13
22	29.82	28.32	26.67
24	32.36	30.86	29.21

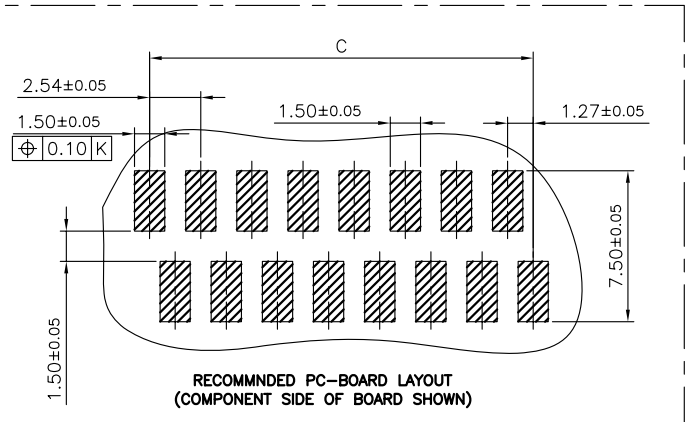
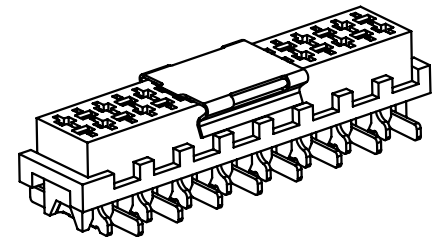

GENERAL TOLERANCE		ANGLE TOLERANCE		PROJECTION	TITLE	MICRO MATCH FEMALE VERTICAL SMT TYPE	
X.	±0.60	X.	±5°	UNITS	mm		
.X	±0.38	.X	±3°	SHEET SIZE	A4	SERIES	DS1015-06 SERIES
.XX	±0.25	.XX	±2°	 晨翔电子有限公司 CONNFLY CONNFLY ELECTRONIC CO. LTD			
DRAWING TYPE		CUSTOMER					
SCALE	1:1	SHEET	1 OF 1				
DRAWING NO.		C-DS1015-06-XXXXX-A					

REV.	DESCRIPTION	DRAWN	CHECKED	APPROVED
A	NEW RELEASE	YCH 03/11/11'	~	

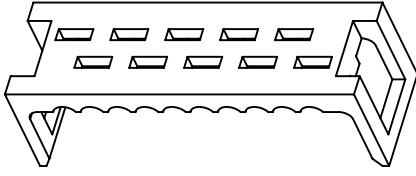
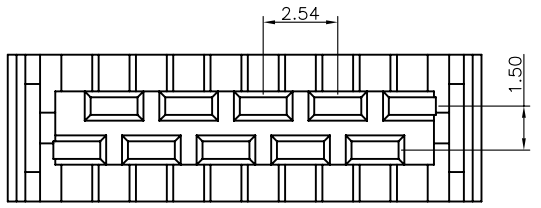
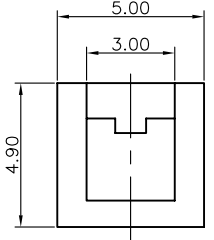
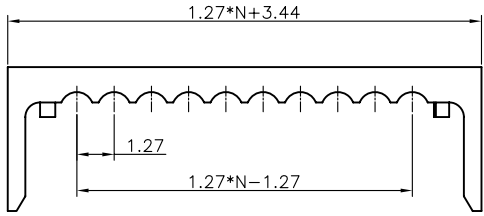

- NOTES:
- MATERIAL
 - INSULATOR:THERMOPLASTIC(UL 94V-0).
 - CONTACT: COPPER ALLOY.
 - SPECIFICATION
 - TEMPERATURE RANGE:-40°C~+105°C.
 - CONTACT RESISTANCE:30mΩ max.
 - INSULATION RESISTANCE:1000MΩ min.
 - DIELECTRIC WITHSTANDING VOLTAGE:AC 500V PER MINUTE.
 - PRODUCT NUMBER CODE:
DS1015-01- X X X

CONTACT PLATING
 2: NICKEL + GOLD FLASH
 6: Full Tin
 8: Full GOLD FLASH

HOUSING COLOR
 R:RED

No. OF CONTACTS
 04 06 08 10 12
 14 16 18 20 24

COVER

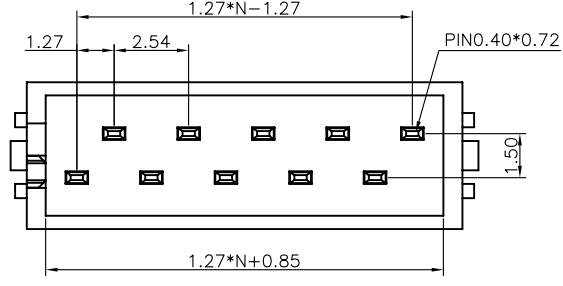
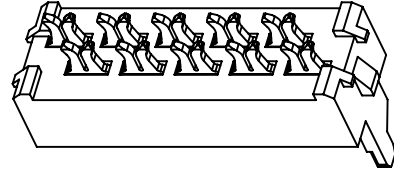
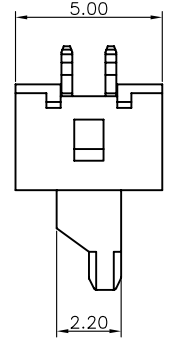
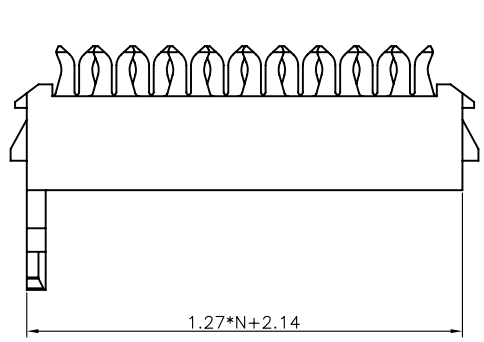

HOUSING

GENERAL TOLERANCE		ANGLE TOLERANCE		PROJECTION		TITLE	MICRO MATCH	
X.	±0.60	X.	±5°	UNITS	mm	MALE ON WIRE CONNECTOR		
.X	±0.38	.X	±3°	SHEET SIZE	A4	SERIES	DS1015-01 SERIES	
.XX	±0.25	.XX	±2°	晨翔电子有限公司 CONNFLY CONNFLY ELECTRONIC CO. LTD				
DRAWING TYPE		CUSTOMER						
SCALE	1:1	SHEET	1 OF 1					
DRAWING NO.		C-DS1015-01-XXX						

REV.	DESCRIPTION	DRAWN	CHECKED	APPROVED
A	NEW RELEASE	YCH 03/11/11'		

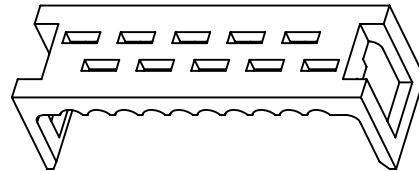
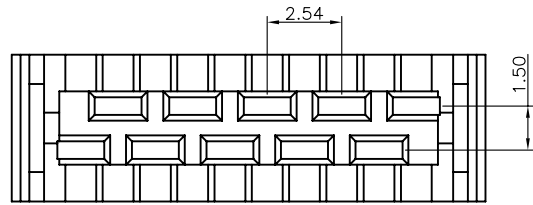
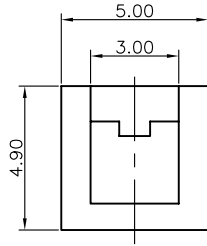
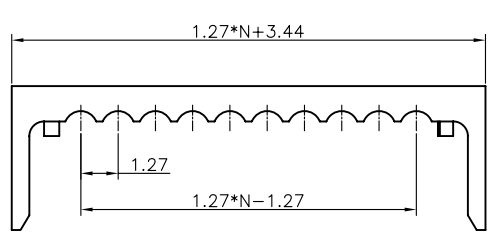

COVER

NOTES:

- MATERIAL
 - INSULATOR:THERMOPLASTIC(UL 94V-0).
 - CONTACT: COPPER ALLOY.
- SPECIFICATION
 - TEMPERATURE RANGE:-40°C~+105°C.
 - CONTACT RESISTANCE:30mΩ max.
 - INSULATION RESISTANCE:1000MΩ min.
 - DIELECTRIC WITHSTANDING VOLTAGE:AC 500V PER MINUTE.
- PRODUCT NUMBER CODE:
DS1015-02- X X X

CONTACT PLATING
2: NICKEL+GOLD FLASH
6: FULL TIN
8: FULL GOLD FLASH

HOUSING COLOR
R:RED

No. OF CONTACTS
04 06 08 10
12 14 16 18
20 24

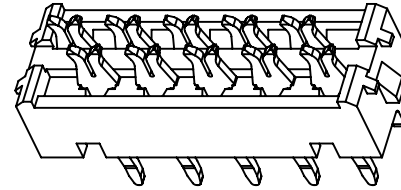
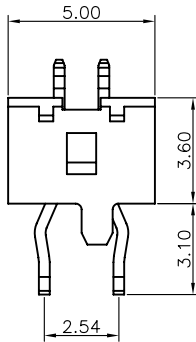
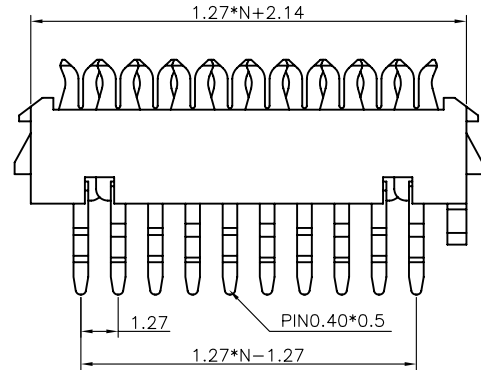

HOUSING





GENERAL TOLERANCE		ANGLE TOLERANCE		PROJECTION		TITLE	MICRO MATCH	
X.	±0.60	X.	±5°	UNITS	mm	PADDEL BOARD CONNECTOR		
.X	±0.38	.X	±3°	SHEET SIZE	A4	SERIES	DS1015-02 SERIES	
.XX	±0.25	.XX	±2°	晨翔电子有限公司 CONNFLY CONNFLY ELECTRONIC CO. LTD				
DRAWING TYPE		CUSTOMER						
SCALE	1:1	SHEET	1 OF 1					
DRAWING NO.		C-DS1015-02-XXX						

DS1015-03 SERIES**RED IDC SERIES W/ FLAT CABLE****CONFLY****MATERIAL**

- ◆ Insulator: Thermoplastic (UL 94V-0)
- ◆ Contact: Copper Alloy

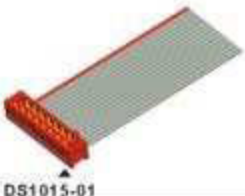
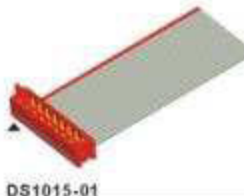
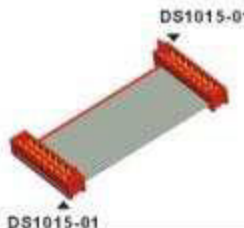
SPECIFICATION

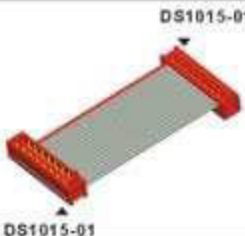
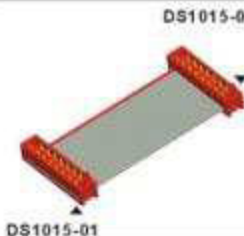
- ◆ Temperature Range: -20°C ~ +80°C
- ◆ Connector Contact Resistance: 20mΩ max. (initial)
- ◆ Insulation Resistance: 1,000MΩ min.
- ◆ Dielectric withstanding voltage: AC 500V per minute

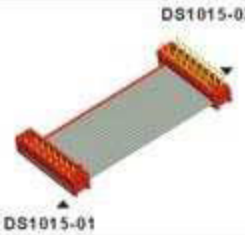
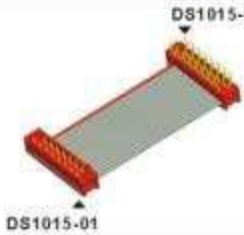
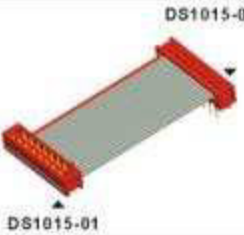
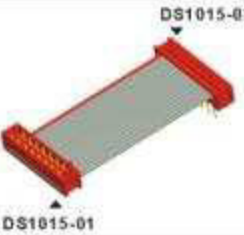
TYPE A	TYPE B	TYPE C	TYPE D
			
TYPE E	TYPE F	TYPE G	TYPE H
			
TYPE J	TYPE K	TYPE M	TYPE N
			
TYPE P	TYPE Q	TYPE R	TYPE S
