

78pin Figure

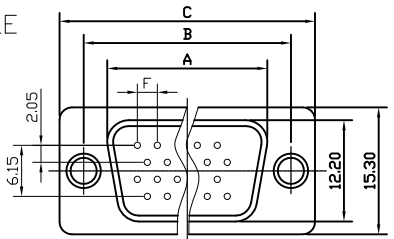

78pin Figure

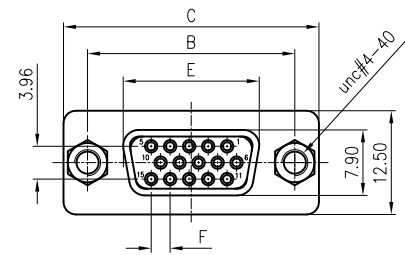
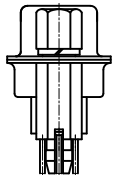
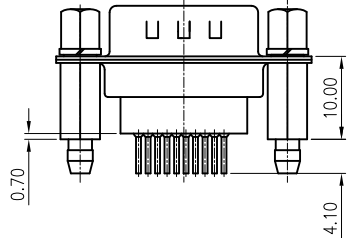
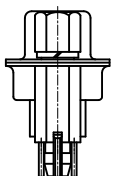
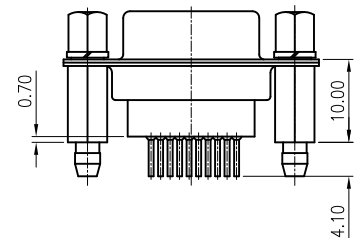

Dimension

Position	A	B	C	E	F
15	17.90	24.99	30.80	16.33	2.29
26	26.50	33.32	39.14	24.66	2.29
44	40.00	47.04	53.04	38.38	2.29
62	56.50	63.50	69.32	54.84	2.41
78	54.30	61.00	67.04	52.34	2.41

REV.	DESCRIPTION	DRAWN	CHECKED	APPROVED
A	NEW RELEASE	YCH 12/31/08'		

NOTES:

- ELECTRICAL CHARACTERISTICS:
  - CONTACT RESISTANCE: 20mΩ Max. INITIAL.
  - DIELECTRIC WITHSTANDING VOLTAGE: 500V AC(rms) FOR 1 MINUTE.
  - INSULATION RESISTANCE: 1000MΩ Min.
- ENVIRONMENT CHARACTERISTICS:
  - OPERATING TEMPERATURE: -40°C~+105°C.
- RESISTANCE TO SOLDERING HEAT: 260±5°C 5±0.5s.
- PRODUCT NUMBER CODE:

DS1077-01- X X X X X X X

- SCREW DIM. A
  - X: W/O Screw
  - 4: 4.80
  - 5: 5.80
- SCREW TYPE
  - X: W/O Fork
  - 3: BR TYPE
  - 4: BRJ TYPE (W/O washer)
  - 7: BRJ TYPE (W/ washer)
- SHELL PLATING
  - T:FORNT & BACK SHELL TIN
  - N:FORNT SHELL NICKEL,BACK SHELL TIN
- CONTACT PLATING
  - 8: FULL GOLD FLASH
  - 0: SELECTIVE GOLD FLASH
- HOUSING COLOR
  - B:BLACK
  - W:WHITE
  - U:BLUE
- CONNECTOR TYPE
  - M:MALE
  - F:FEMALE
- No.OF CONTACTS
  - 15 26 44 62 78

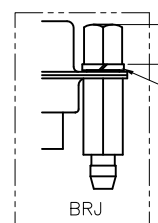
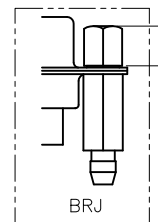
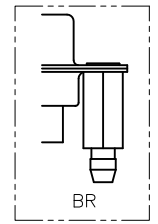

GENERAL TOLERANCE		ANGLE TOLERANCE	
X.	±0.60	X.	±5°
.X	±0.38	.X	±3°
.XX	±0.25	.XX	±2°

PROJECTION		TITLE	
UNITS	mm	D-SUB H.D DIP TYPE PROFILE HEIGHT=10.0mm	
SHEET SIZE	A4	SERIES	DS1077-01 SERIES

DRAWING TYPE	CUSTOMER		
SCALE	1:1	SHEET	1 OF 1
DRAWING NO.	C-DS177-01-XXXXXXX		

晨翔电子有限公司  
CONNFLY CONNFLY ELECTRONIC CO. LTD

REV.	DESCRIPTION	DRAWN	CHECKED	APPROVED
A	NEW RELEASE	LJH 04/27/05'		LJH 04/22/06'
B	ADD SCREW TYPE	DMJ 06/27/07'		LJC 06/27/07'
C	整理图面	YCH 05/21/08'		LJC 05/21/08'
E	整理图面	YCH 04/09/11'		

NOTES:

- ELECTRICAL CHARACTERISTICS:
  - CONTACT RESISTANCE: 20mΩ Max. INITIAL.
  - DIELECTRIC WITHSTANDING VOLTAGE: 500V AC(rms) FOR 1 MINUTE.
  - INSULATION RESISTANCE: 1000MΩ Min.
- ENVIRONMENT CHARACTERISTICS:
 

TEMPERATURE RANGE: -40°C~+105°C.
- PART NUMBER: DS1034
- PRODUCT NUMBER CODE:
 

DS1034- X X X X X X X

  - SCREW DIM. A
    - S: Standard(W/O nut)
    - 1: 5.00
    - 2: 3.00
    - 3: 5.20
    - 4: 4.80
    - 5: 5.80
    - 6: 4.00
    - 7: 4.80mm(Inside thread M2.6\*0.45p, outside thread unc#4-40)
  - SCREW TYPE
    - S: Standard(W/O nut)
    - 1: CC TYPE
    - 2: CS TYPE
    - 3: BR TYPE
    - 4: BRJ TYPE DIM. B:6.00 C: 3~4mm
    - 5: BRJ TYPE DIM. B:6.00 C: 5~6mm
    - 6: BRJ TYPE DIM. B:6.00 C: 3~4mm (Inside thread M2.6\*0.45P,outside thread unc#4-40)
    - 7: BRJ TYPE DIM. B:6.00 C: 3~4mm (Inside thread M3.0\*0.50P,outside thread unc#4-40)
  - CONTACT PLATING
    - Si: FULL GOLD FLASH
    - 0: SELECTIVE GOLD FLASH
  - SHELL PLATING
    - T: FORNT & BACK SHELL TIN
    - N: FORNT SHELL NICKEL,BACK SHELL TIN
  - HOUSING COLOR
    - B: BLACK
    - W: WHITE
    - U: BLUE
  - CONNECTOR TYPE
    - M: MALE
    - F: FEMALE
  - No.OF CONTACTS
    - 09: 9pos. 25: 25pos.
    - 15: 15pos. 37: 37pos.

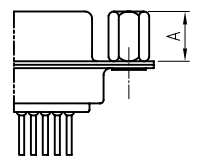
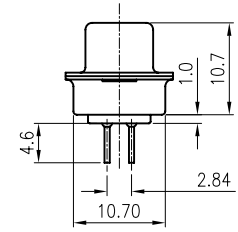
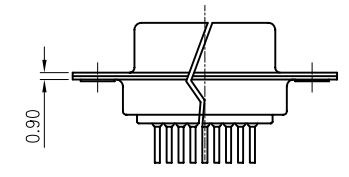
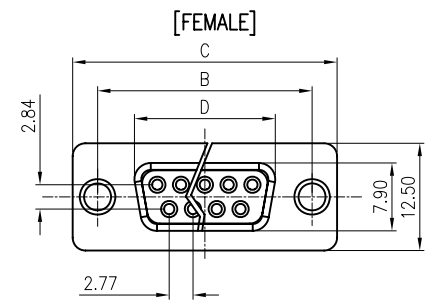

CC TYPE

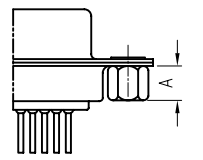

CS TYPE

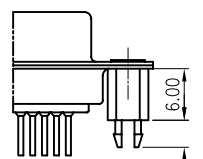

BR TYPE

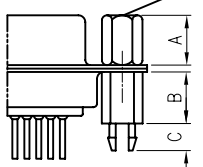

BRJ TYPE

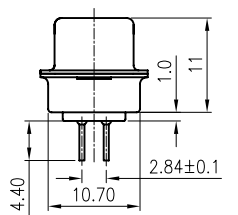
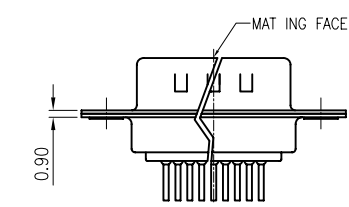
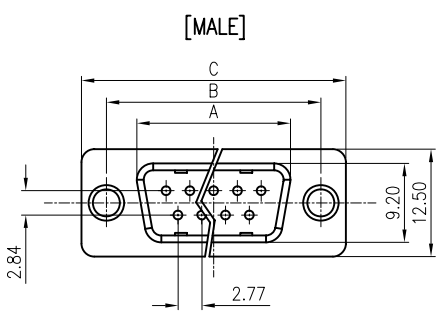
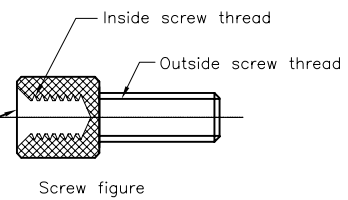

Dimension

Position	A±0.2	B±0.2	C±0.3	D
9	17.90	24.99	30.80	16.33
15	26.50	33.32	39.14	24.66
25	40.00	47.04	53.04	38.38
37	56.50	63.50	69.32	54.84

GENERAL TOLERANCE		ANGLE TOLERANCE	
X.	±0.60	X.	±5'
.X	±0.38	.X	±3'
.XX	±0.25	.XX	±2'

DRAWING TYPE	CUSTOMER		
SCALE	1:1	SHEET	1 OF 1
DRAWING NO.	C-DS1034-XXXXXXX		

PROJECTION	TITLE
	D-SUB DIP STRAIGHT TYPE
UNITS	mm
SHEET SIZE	A4
SERIES	DS1034 SERIES

晨翔电子有限公司  
CONNFLY CONNFLY ELECTRONIC CO. LTD

REV.	DESCRIPTION	DRAWN	CHECKED	APPROVED
A	NEW RELEASE	YCH 08/18/07'	~	

NOTES:

- ELECTRICAL CHARACTERISTICS:
  - CONTACT RESISTANCE: 20mΩ Max. INITIAL.
  - DIELECTRIC WITHSTANDING VOLTAGE: 500V AC(rms) FOR 1 MINUTE.
  - INSULATION RESISTANCE: 1000MΩ Min.
- ENVIRONMENT CHARACTERISTICS:
  - TEMPERATURE: -40°C~+105°C.
- RESISTANCE TO SOLDERING HEAT: 260±5°C 5±0.5s.
- PRODUCT NUMBER CODE:

DS1034-01- X X X X X X

- SCREW DIM. A
- X: W/O Screw
- 4: 4.80
- 5: 5.80
- SCREW TYPE
- X: W/O Fork
- 3: BR TYPE
- 4: BRJ TYPE (W/O washer)
- 7: BRJ TYPE (W/ washer)
- CONTACT PLATING
- Si: FULL GOLD FLASH
- 0: SELECTIVE GOLD FLASH
- SHELL PLATING
- T: FORNT & BACK SHELL TIN
- N: FORNT SHELL NICKEL, BACK SHELL TIN
- HOUSING COLOR
- B: BLACK
- W: WHITE
- U: BLUE
- CONNECTOR TYPE
- M: MALE
- F: FEMALE
- No.OF CONTACTS
- 09: 9pos.
- 15: 15pos.
- 25: 25pos.
- 37: 37pos.

Dimension

Position	A±0.2	B±0.2	C±0.3	D
9	17.90	24.99	30.80	16.33
15	26.50	33.32	39.14	24.66
25	40.00	47.04	53.04	38.38
37	56.50	63.50	69.32	54.84

GENERAL TOLERANCE		ANGLE TOLERANCE	
X.	±0.60	X.	±5'
.X	±0.38	.X	±3'
.XX	±0.25	.XX	±2'

PROJECTION	TITLE
	D-SUB DIP STRAIGHT WITH FORK TYPE
UNITS	mm
SHEET SIZE	A4
SERIES	DS1034-01 SERIES

DRAWING TYPE	CUSTOMER
SCALE	1:1 SHEET 1 OF 1
DRAWING NO.	C-DS1034-01-XXXXXX

晨翔电子有限公司  
**CONNFLY CONNFLY ELECTRONIC CO. LTD**

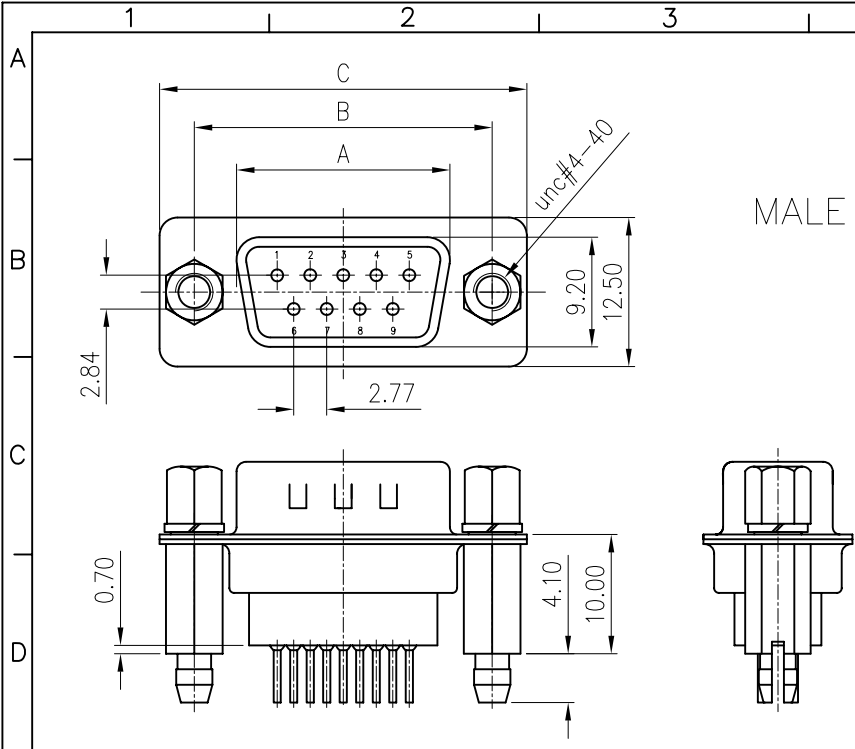

MALE

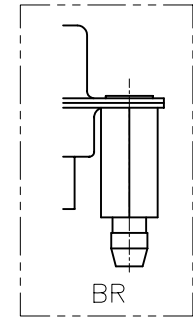

BR

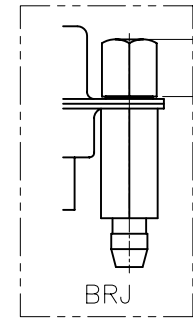

BRJ

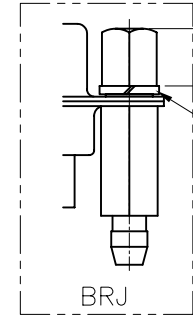

BRJ

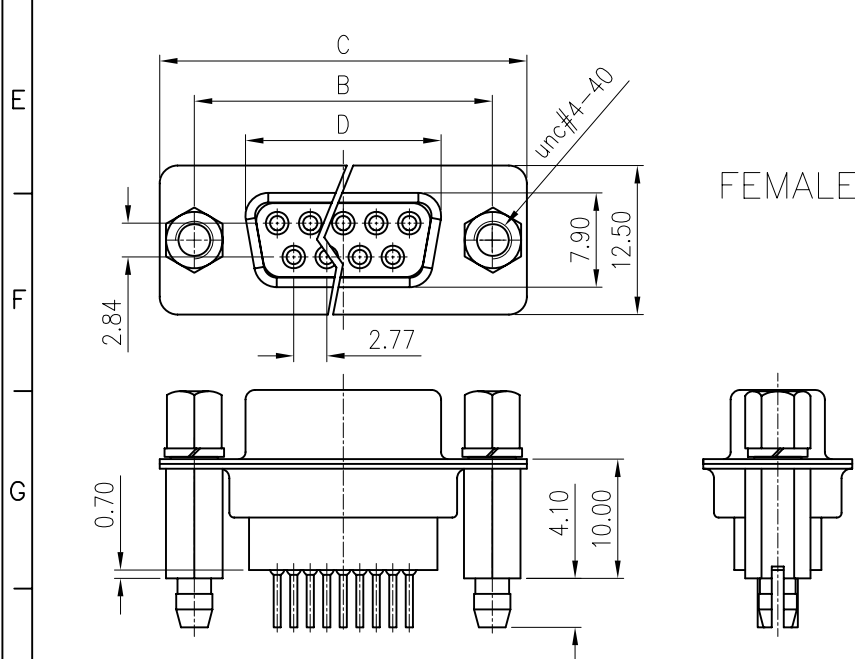

FEMALE