

BOM LIST			
ITEM	PART NAME	Q'ty	NOTES
1	METAL HOOD	2	
2	LONG BOLT	2	
3	SCREW	2	
4	SMALL WASHER	2	
5	NUT	2	
6	SHORT BOLT	2	

REV.	DESCRIPTION	DRAWN	CHECKED	APPROVED
A	NEW RELEASE	LJH 03/02/07'	~	LJC 03/02/07'
B	整理英制短螺丝尺寸	YCH 07/18/08'	~	

NOTES:

1. PART NUMBER CODE:

DS1047 - 09 X X X

- Bolt type
- L: Long
- S: Short
- Packing type
- 1: Mix packing
- 2: Separation packing
- Cover Material
- M: Metal(Zinc alloy)
- Positions
- 09: 9pin

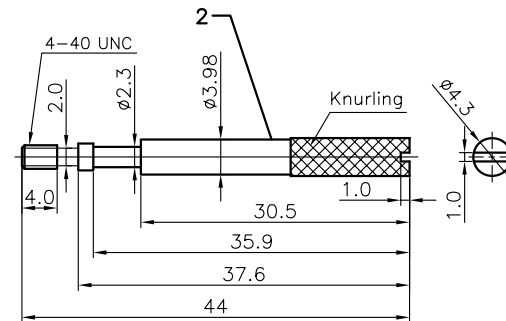
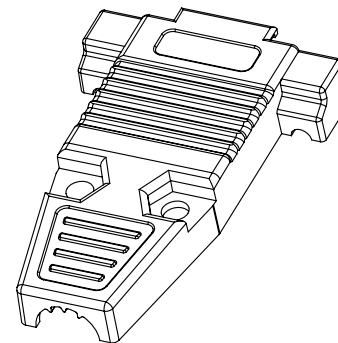
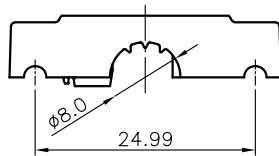
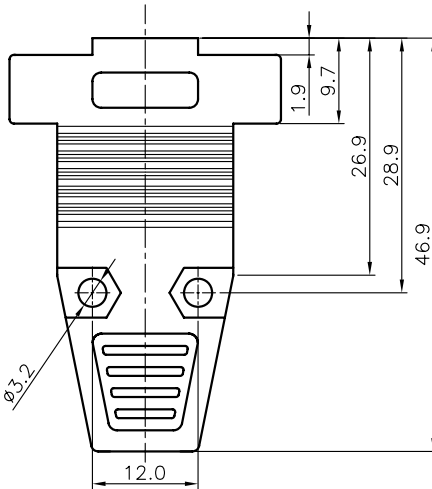
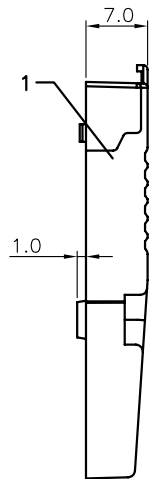
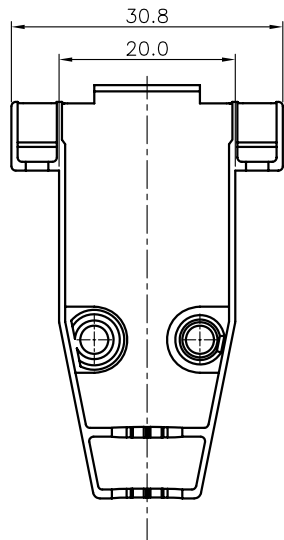

Long BOLT

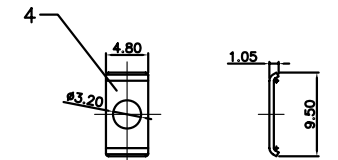

SMALL WASHER

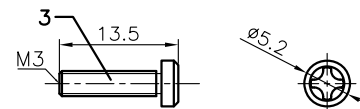

SCREW

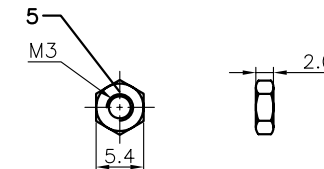

NUT

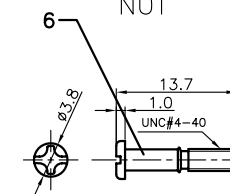

Short BOLT

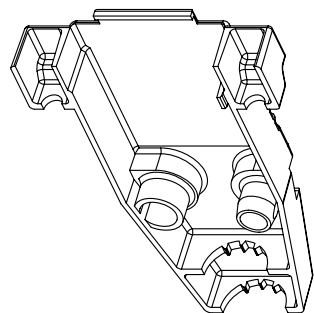

GENERAL TOLERANCE		ANGLE TOLERANCE		PROJECTION	TITLE	D-SUB 9pin Metal Cover	
X.	± 0.60	X.	$\pm 5^\circ$	UNITS	mm		
.X	± 0.38	.X	$\pm 3^\circ$	SHEET SIZE	A4	SERIES	DS1047 SERIES
.XX	± 0.25	.XX	$\pm 2^\circ$	晨翔电子有限公司 CONNFLY CONNFLY ELECTRONIC CO. LTD			
DRAWING TYPE		COSTOMER					
SCALE	1:1	SHEET	1 OF 1				
DRAWING NO.		C-DS1047-09XXX-B					

BOM LIST			
ITEM	PART NAME	Q'ty	NOTES
1	METAL HOOD	2	
2	BOLT	2	
3	SCREW	2	
4	NUT	2	

REV.	DESCRIPTION	DRAWN	CHECKED	APPROVED
A	NEW RELEASE	LJC 03/02/07'		

NOTES:

1. PART NUMBER CODE:
DS1047 - 15 X X X

- Bolt type
L: Long
- Packing type
1: Mix packing
2: Separation packing
- Cover Material
M: Metal(Znic alloy)
- Positions
15: 15pin

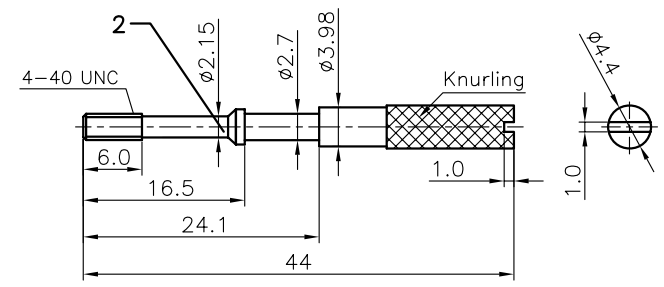
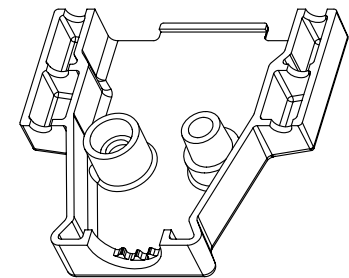
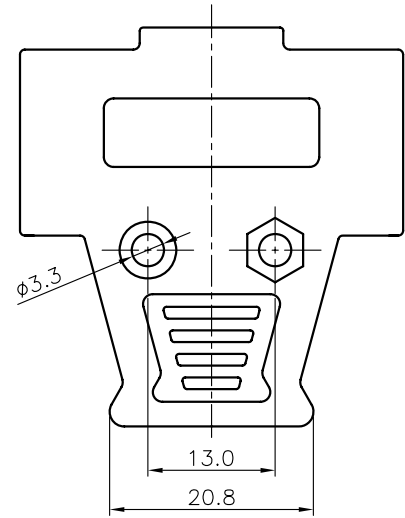
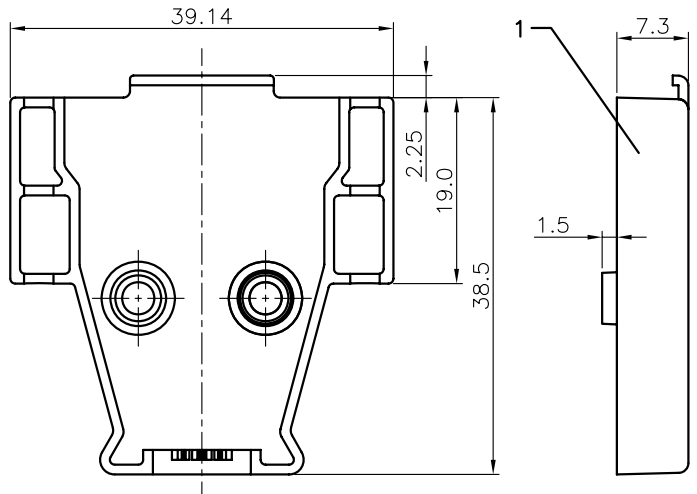

BOLT

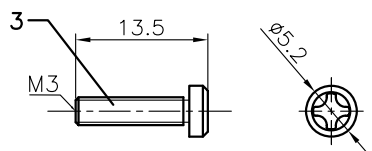
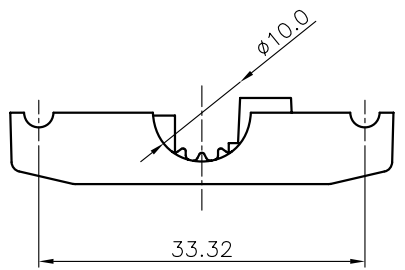

SCREW

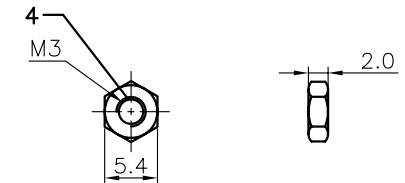

NUT

GENERAL TOLERANCE		ANGLE TOLERANCE		PROJECTION		TITLE	D-SUB 15pin Metal Cover	
X.	±0.60	X.	±5°	UNITS	mm	SHEET	DS1047 SERIES	
.X	±0.38	.X	±3°	SHEET SIZE	A4			
.XX	±0.25	.XX	±2°	晨翔电子有限公司 CONNFLY CONNFLY ELECTRONIC CO. LTD				
DRAWING TYPE		COSTOMER						
SCALE	1:1	SHEET	1 OF 1					
DRAWING NO.		C-DS1047-15XXX						

BOM LIST			
ITEM	PART NAME	Q'ty	NOTES
1	METAL HOOD	2	
2	BOLT	2	
3	NUT	2	
4	SCREW-1	2	
5.1	METAL WASHER	2	
5.2	PLASTIC-1 WASHER	2	
5.3	PLASTIC-2 WASHER	2	
6	SCREW-2	2	
7	SR	1	

REV.	DESCRIPTION	DRAWN	CHECKED	APPROVED
A	NEW RELEASE	LJC 03/02/07'	~	LJC 03/02/07'
B	整理图面	YCH 09/14/07'	~	

NOTES:
1. PART NUMBER CODE:

DS1047 - 25 X X X X

- Wash type
- 1: Metal
- 2: Plastic-1(Lock type)
- 3: Plastic-2(Screw type)
- Long type
- L: Long
- Packing type
- 1: Mix packing
- 2: Separation packing
- Cover Material
- M: Metal(Znic alloy)
- Positions
- 25: 25pin

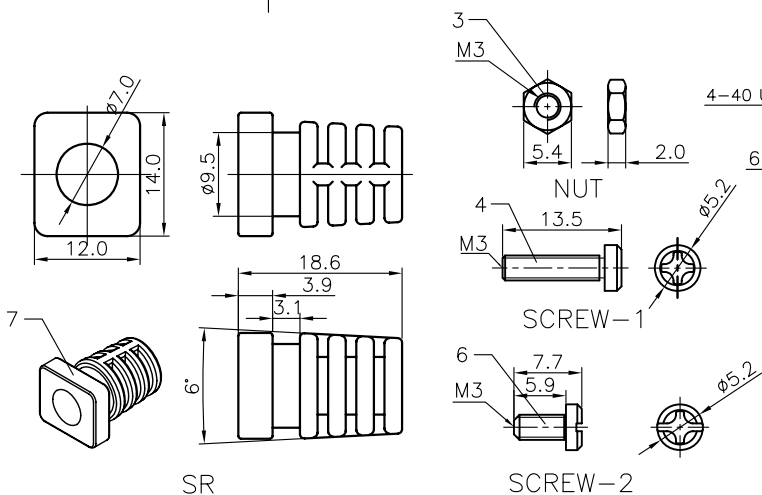
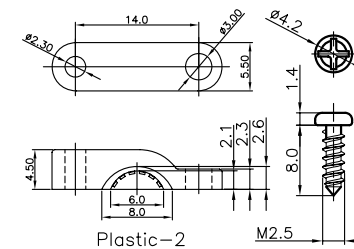
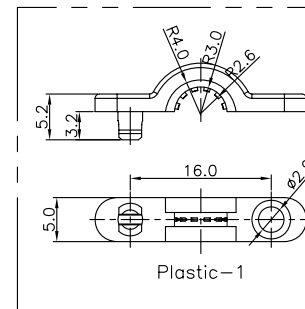
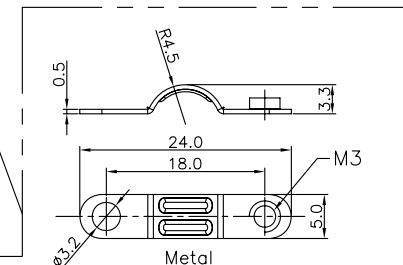
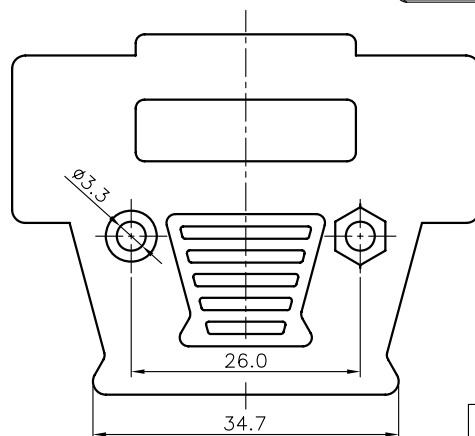
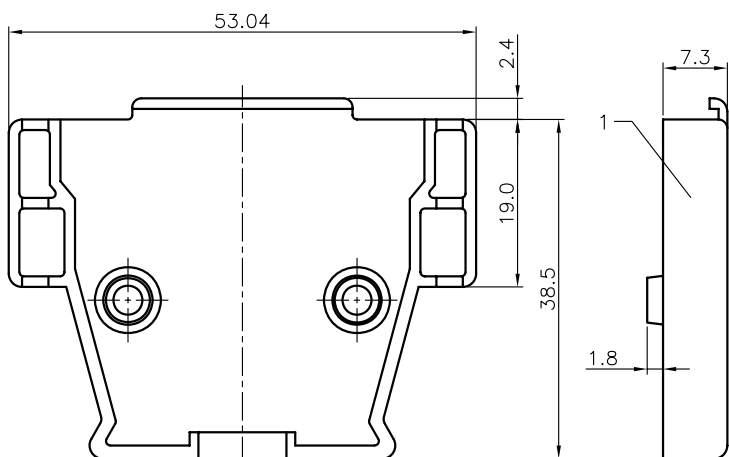
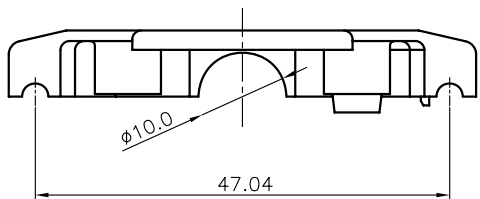
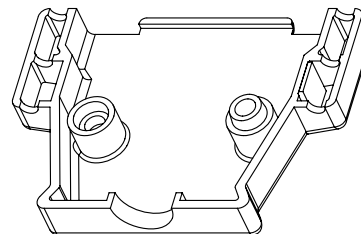

GENERAL TOLERANCE	ANGLE TOLERANCE
X. ± 0.60	X. $\pm 5^\circ$
.X ± 0.38	.X $\pm 3^\circ$
.XX ± 0.25	.XX $\pm 2^\circ$

PROJECTION	TITLE	D-SUB 25pin Metal Cover	
UNITS	mm	SHEET SIZE	A4
SHEET SIZE	A4	SERIES	DS1047 SERIES

DRAWING TYPE	CUSTOMER
SCALE	1:1
DRAWING NO.	C-DS1047-25XXXX

晨翔电子有限公司
CONNFLY CONNFLY ELECTRONIC CO. LTD

BOM LIST			
ITEM	PART NAME	Q'ty	NOTES
1	METAL HOOD	2	
2	BOLT	2	
3	SCREW	2	
4	NUT	2	

REV.	DESCRIPTION	DRAWN	CHECKED	APPROVED
A	NEW RELEASE	LJC 03/02/07'		

NOTES:

1. PART NUMBER CODE:

DS1047 - 37 X X X

- X Bolt type
- L: Long
- X Packing type
- 1: Mix packing
- 2: Separation packing
- X Cover Material
- M: Metal(Znic alloy)
- X Positions
- 37: 37pin

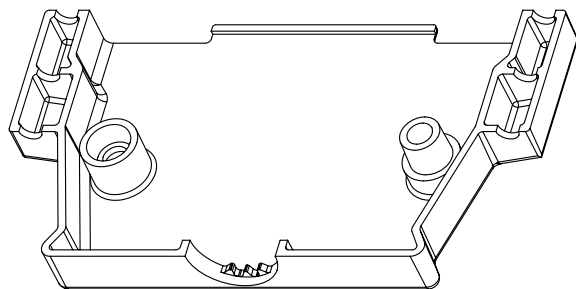
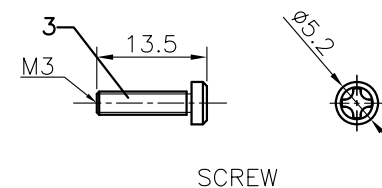
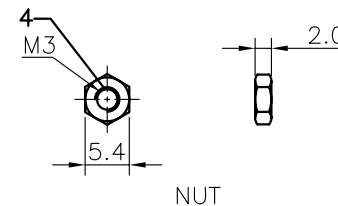
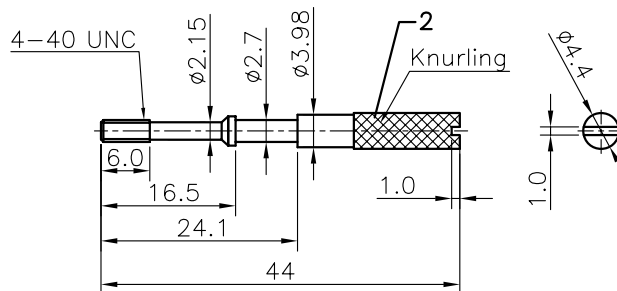
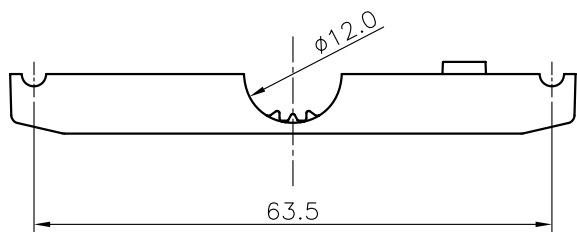
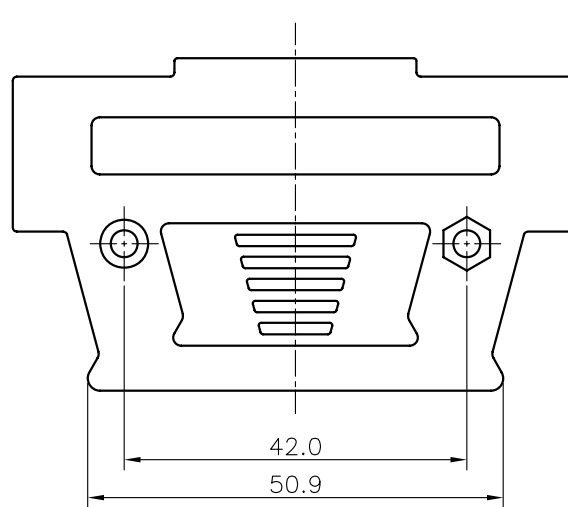
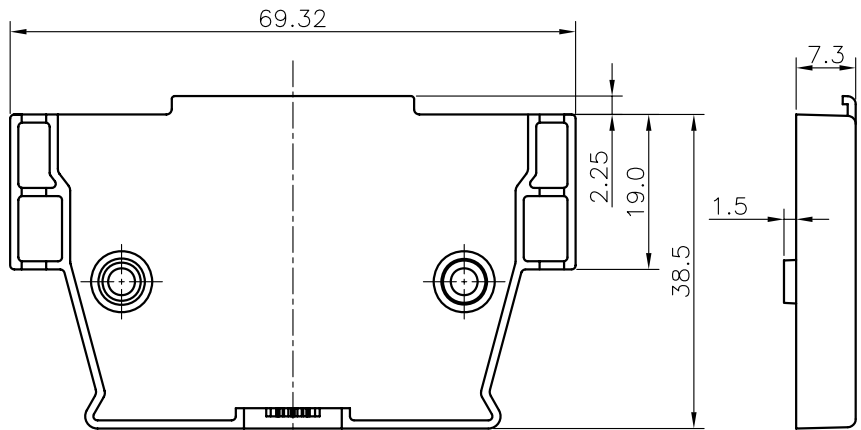

GENERAL TOLERANCE		ANGLE TOLERANCE		PROJECTION		TITLE	
X	±0.60	X	±5°	UNITS	mm	D-SUB 37pin Metal Cover	
.X	±0.38	.X	±3°	SHEET SIZE	A4	SERIES	DS1047 SERIES
.XX	±0.25	.XX	±2°	晨翔电子有限公司 CONNFLY CONNFLY ELECTRONIC CO. LTD			
DRAWING TYPE		COSTOMER					
SCALE	1:1	SHEET	1 OF 1				
DRAWING NO.		C-DS1047-37XXX					

	φF
W/ SR	φ6.5
W/O SR	φ3.0~φ9.5

REV.	DESCRIPTION	DRAWN	CHECKED	APPROVED
A	NEW RELEASE	YCH 03/22/11'	~	

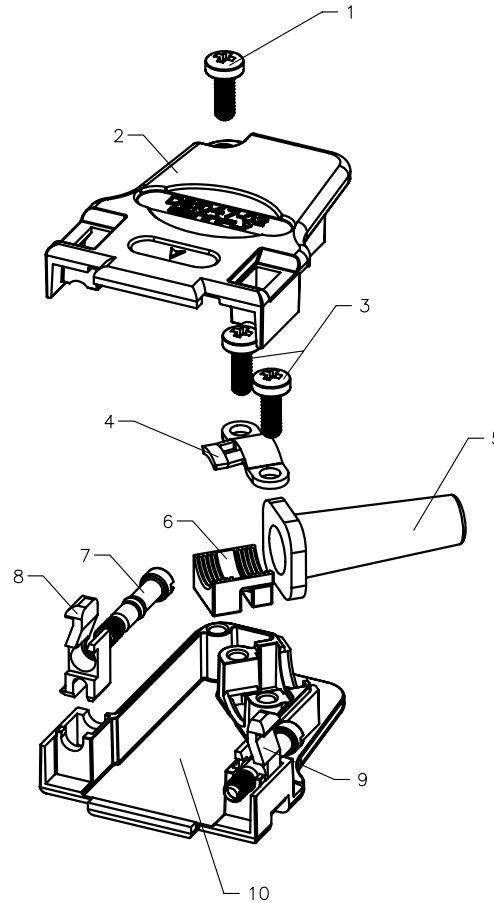
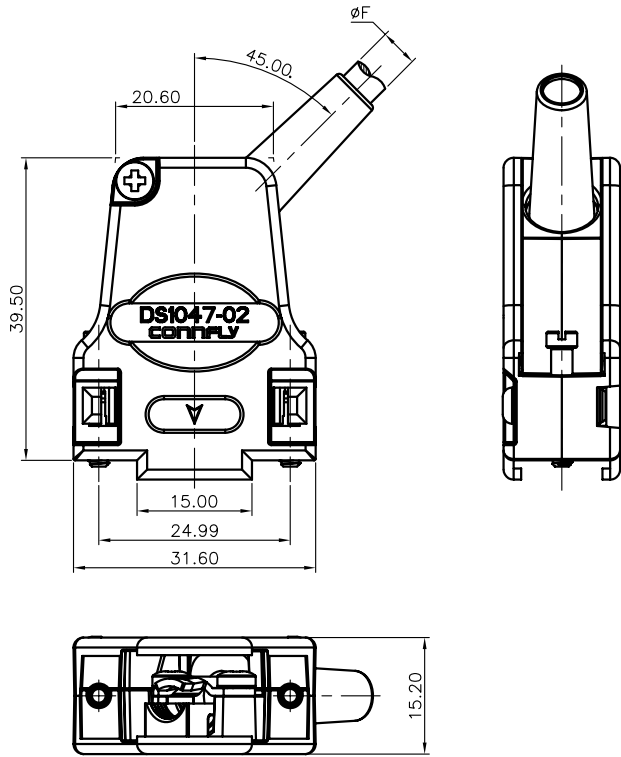

NOTES:

1. PART NUMBER CODE:

DS1047-02 - 09 X X X

- SR Support
- S: W/ SR
- X: W/O SR
- Packing type
- 1: Mix packing
- 2: Separation packing
- Cover Material
- M: Metal(Znic alloy)
- Positions
- 09: 9pin

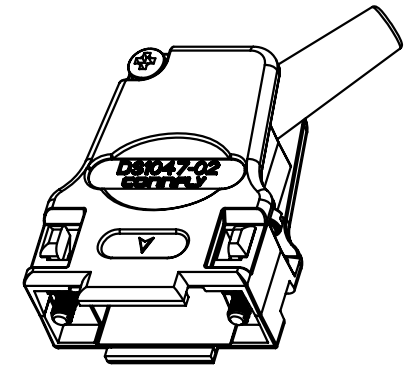

BOM LIST			
ITEM	PART NAME	Q'ty	NOTES
1	SCREW M2.5*8	1	M2.5
2	METAL HOOD-1	1	Znic alloy
3	SCREW M2.5*6	2	M2.5
4	WASHER	1	
5	SR	1	
6	STRAIN RELIEF	1	
7	BOLT	2	UNC 4-40
8	LATCH-1	1	
9	LATCH-2	1	
10	METAL HOOD-2	1	Znic alloy

GENERAL TOLERANCE		ANGLE TOLERANCE		PROJECTION		TITLE	D-SUB 9pin Metal Hoods Large Angled Cable Outlet	
X.	±0.60	X.	±5°	UNITS	mm			
.X	±0.38	.X	±3°	SHEET SIZE	A4	SERIES	DS1047-02 SERIES	
.XX	±0.25	.XX	±2°	晨翔电子有限公司 CONNPLY CONNPLY ELECTRONIC CO. LTD				
DRAWING TYPE		CUSTOMER						
SCALE		1:1						
DRAWING NO.		C-DS1047-02-09XXX						

øF		
TYPE A	W/ SR	ø6.5
	W/O SR	ø3.0~ø9.5
TYPE B	W/ SR	ø9.0
	W/O SR	ø8.5~ø12.5

REV.	DESCRIPTION	DRAWN	CHECKED	APPROVED
A	NEW RELEASE	YCH 03/22/11'	~	

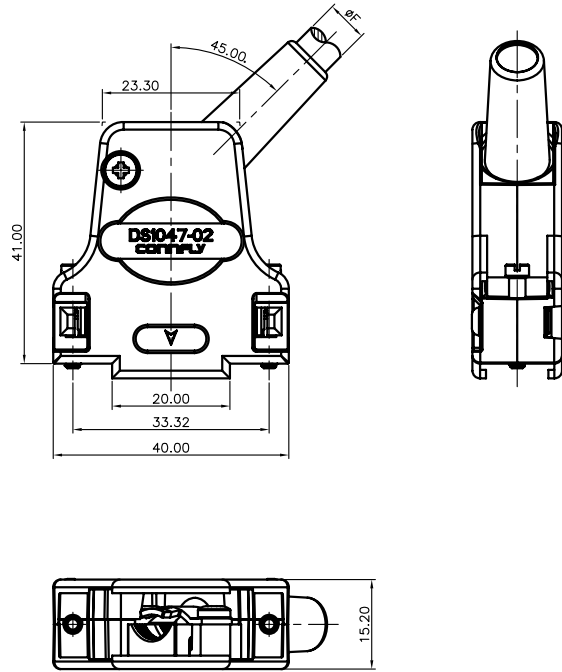

NOTES:

1. PART NUMBER CODE:

DS1047-02 - 15 X X X X

- SR Support
- S: W/ SR
- X: W/O SR
- Type Support
- A: Type A
- B: Type B
- Packing type
- 1: Mix packing
- 2: Separation packing
- Cover Material
- M: Metal(Znic alloy)
- Positions
- 15: 15pin

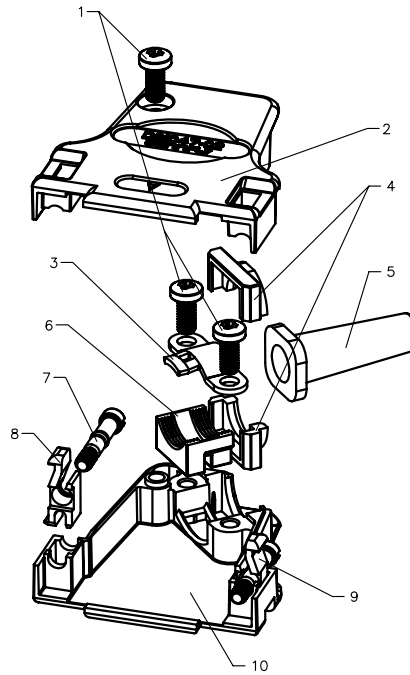

TYPE A

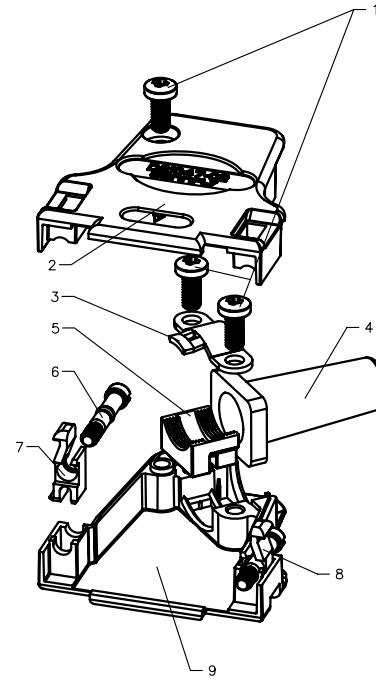

TYPE B

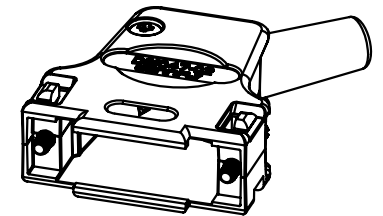

TYPE A BOM LIST			
ITEM	PART NAME	Q'ty	NOTES
1	SCREW	3	M3
2	METAL HOOD-1	1	Znic alloy
3	WASHER	1	
4	CABLE REDUCTION PLATE	2	
5	SR	1	
6	STRAIN RELIEF	1	
7	BOLT	2	UNC 4-40
8	LATCH-1	1	
9	LATCH-2	1	
10	METAL HOOD-2	1	Znic alloy

TYPE B BOM LIST			
ITEM	PART NAME	Q'ty	NOTES
1	SCREW	3	M3
2	METAL HOOD-1	1	Znic alloy
3	WASHER	1	
4	SR	1	
5	STRAIN RELIEF	1	
6	BOLT	2	UNC 4-40
7	LATCH-1	1	
8	LATCH-2	1	
9	METAL HOOD-2	1	Znic alloy

GENERAL TOLERANCE	ANGLE TOLERANCE
X. ±0.60	X. ±5°
.X ±0.38	.X ±3°
.XX ±0.25	.XX ±2°

PROJECTION	TITLE
	D-SUB 15pin Metal Hoods Large Angled Cable Outlet
UNITS	mm
SHEET SIZE	A4
SERIES	DS1047-02 SERIES

DRAWING TYPE	COSTOMER
SCALE	1:1 SHEET 1 OF 1
DRAWING NO.	C-DS1047-02-15XXXX

晨翔电子有限公司
CONNFLY CONNFLY ELECTRONIC CO. LTD

		φF
TYPE A	W/ SR	φ8
	W/O SR	φ3.0~φ8.5
TYPE B	W/ SR	φ9.0
	W/O SR	φ8.5~φ12.5

REV.	DESCRIPTION	DRAWN	CHECKED	APPROVED
A	NEW RELEASE	YCH 03/22/11'	~	

NOTES:
1. PART NUMBER CODE:
DS1047-02 - 25 X X X X

- SR Support
- S: W/ SR
- X: W/O SR
- Type Support
- A: Type A
- B: Type B
- Packing type
- 1: Mix packing
- 2: Separation packing
- Cover Material
- M: Metal(Znic alloy)
- Positions
- 25: 25pin

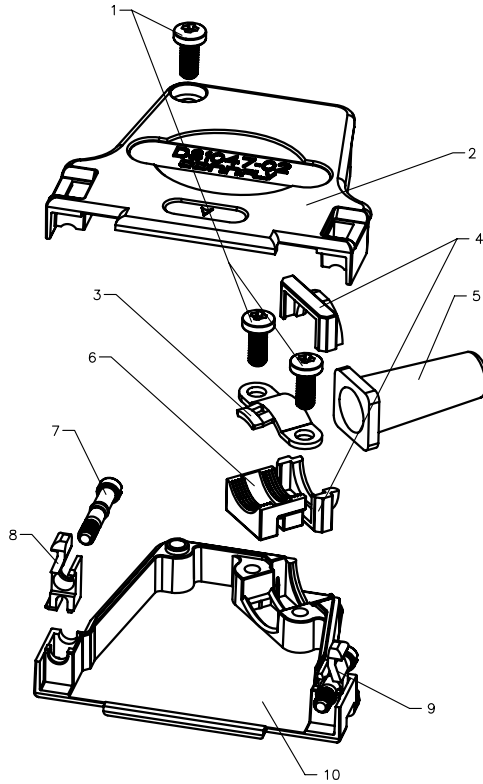
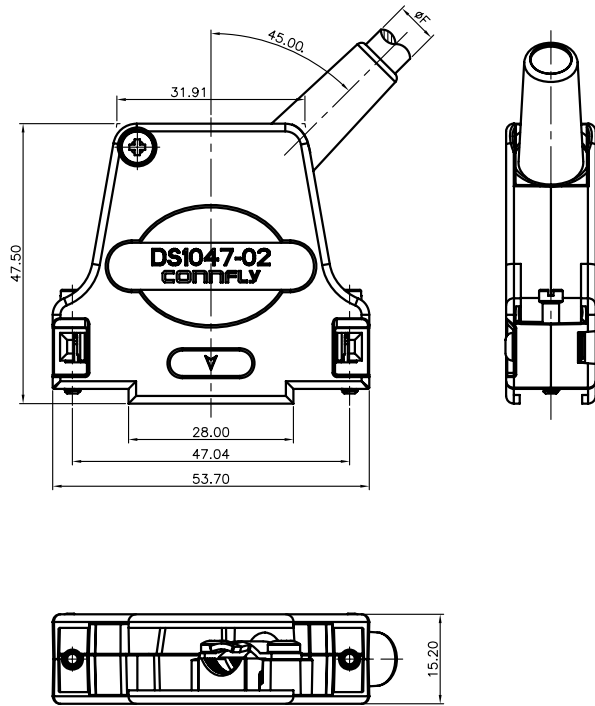

TYPE A

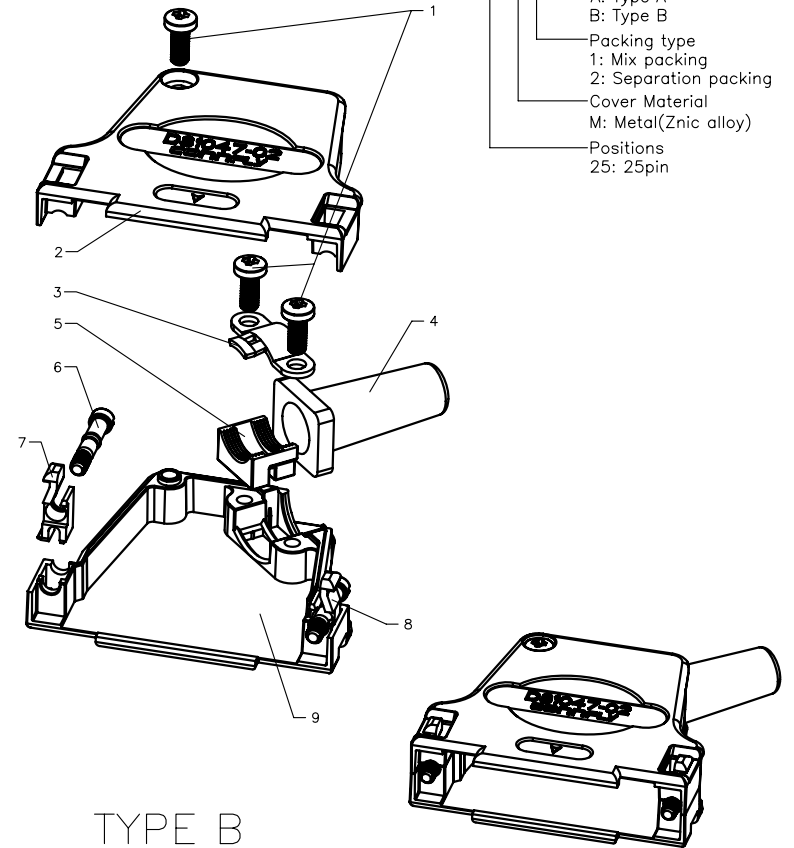

TYPE B

TYPE A BOM LIST			
ITEM	PART NAME	Q'ty	NOTES
1	SCREW	3	M3
2	METAL HOOD-1	1	Znic alloy
3	WASHER	1	
4	CABLE REDUCTION PLATE	2	
5	SR	1	
6	STRAIN RELIEF	1	
7	BOLT	2	UNC 4-40
8	LATCH-1	1	
9	LATCH-2	1	
10	METAL HOOD-2	1	Znic alloy

TYPE B BOM LIST			
ITEM	PART NAME	Q'ty	NOTES
1	SCREW	3	M3
2	METAL HOOD-1	1	Znic alloy
3	WASHER	1	
4	SR	1	
5	STRAIN RELIEF	1	
6	BOLT	2	UNC 4-40
7	LATCH-1	1	
8	LATCH-2	1	
9	METAL HOOD-2	1	Znic alloy

GENERAL TOLERANCE	ANGLE TOLERANCE
X. ±0.60	X. ±5°
.X ±0.38	.X ±3°
.XX ±0.25	.XX ±2°

PROJECTION	TITLE
	D-SUB 25pin Metal Hoods Large Angled Cable Outlet
UNITS	mm
SHEET SIZE	A4
SERIES	DS1047-02 SERIES

DRAWING TYPE	COSTOMER
SCALE	1:1 SHEET 1 OF 1
DRAWING NO.	C-DS1047-02-25XXXX

晨翔电子有限公司
CONNPLY CONNPLY ELECTRONIC CO. LTD

REV.	DESCRIPTION	DRAWN	CHECKED	APPROVED
A	NEW RELEASE	YCH 03/22/11'	~	

	φF	
TYPE A	W/ SR	φ9
	W/O SR	φ3.0~φ12.0
TYPE B	W/ SR	φ11.5
	W/O SR	φ12.0~φ15.0

NOTES:
 1. PART NUMBER CODE:
 DS1047-02 - 37 X X X X

- SR Support
- S: W/ SR
- X: W/O SR
- Type Support
- A: Type A
- B: Type B
- Packing type
- 1: Mix packing
- 2: Separation packing
- Cover Material
- M: Metal(Znic alloy)
- Positions
- 37: 37pin

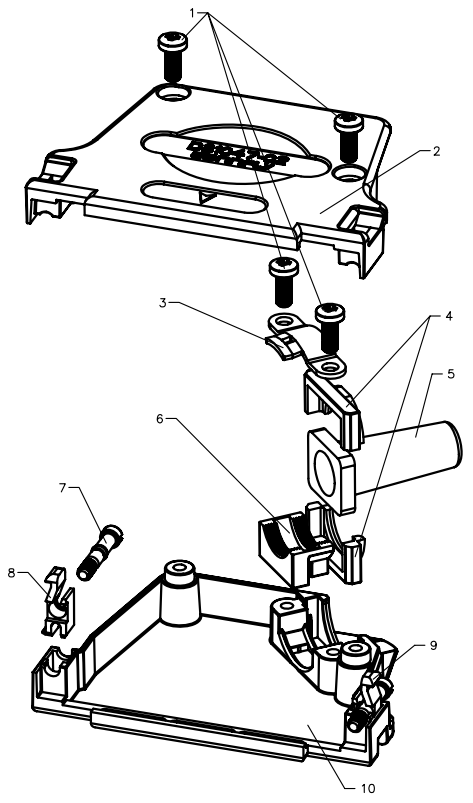
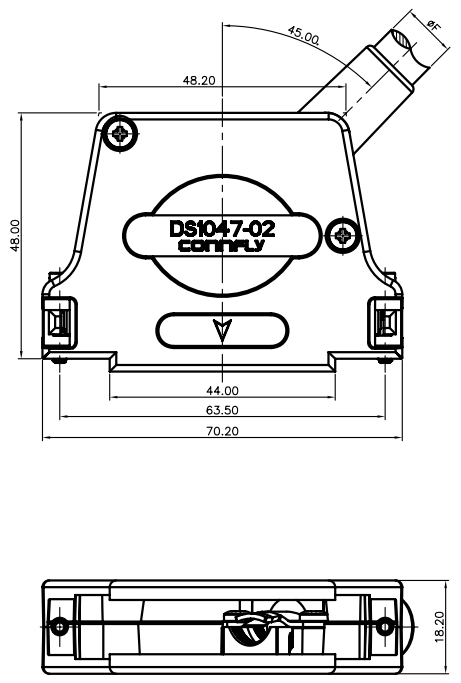

TYPE A

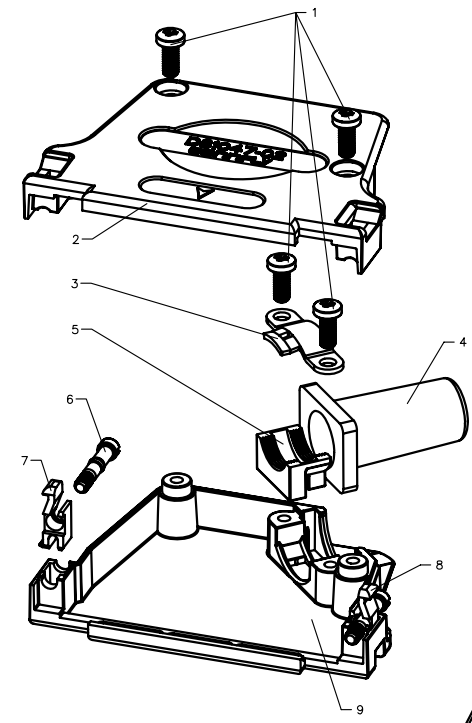

TYPE B

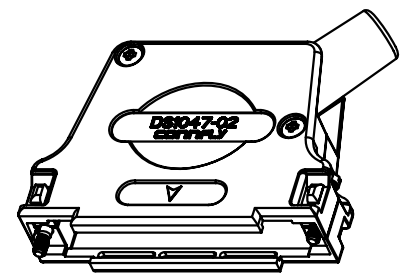

TYPE A BOM LIST			
ITEM	PART NAME	Q'ty	NOTES
1	SCREW	4	M3
2	METAL HOOD-1	1	Znic alloy
3	WASHER	1	
4	CABLE REDUCTION PLATE	2	
5	SR	1	
6	STRAIN RELIEF	1	
7	BOLT	2	UNC 4-40
8	LATCH-1	1	
9	LATCH-2	1	
10	METAL HOOD-2	1	Znic alloy

TYPE B BOM LIST			
ITEM	PART NAME	Q'ty	NOTES
1	SCREW	4	M3
2	METAL HOOD-1	1	Znic alloy
3	WASHER	1	
4	SR	1	
5	STRAIN RELIEF	1	
6	BOLT	2	UNC 4-40
7	LATCH-1	1	
8	LATCH-2	1	
9	METAL HOOD-2	1	Znic alloy

GENERAL TOLERANCE	ANGLE TOLERANCE
X. ±0.60	X. ±5°
.X ±0.38	.X ±3°
.XX ±0.25	.XX ±2°

PROJECTION	TITLE
UNITS	D-SUB 37pin Metal Hoods
SHEET SIZE	Large Angled Cable Outlet
	SERIES DS1047-02 SERIES

DRAWING TYPE	COSTOMER
SCALE	1:1 SHEET 1 OF 1
DRAWING NO.	C-DS1047-02-37XXXX

晨翔电子有限公司
CONNPLY CONNPLY ELECTRONIC CO. LTD

REV.	DESCRIPTION	DRAWN	CHECKED	APPROVED
A	NEW RELEASE	YCH 12/31/09'	~	

NOTES:

1. PART NUMBER CODE:

DS1047-04 - 09 X X

Packing type
 1: Mix packing
 2: Separation packing
 Cover Material
 M: Metal(Znic alloy)
 Positions
 09: 9pin

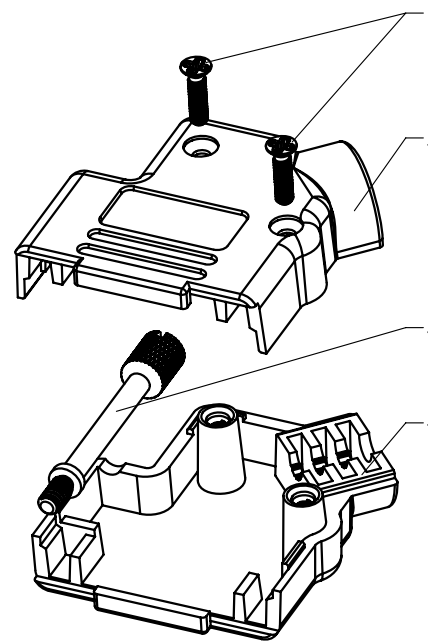
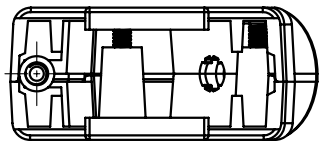
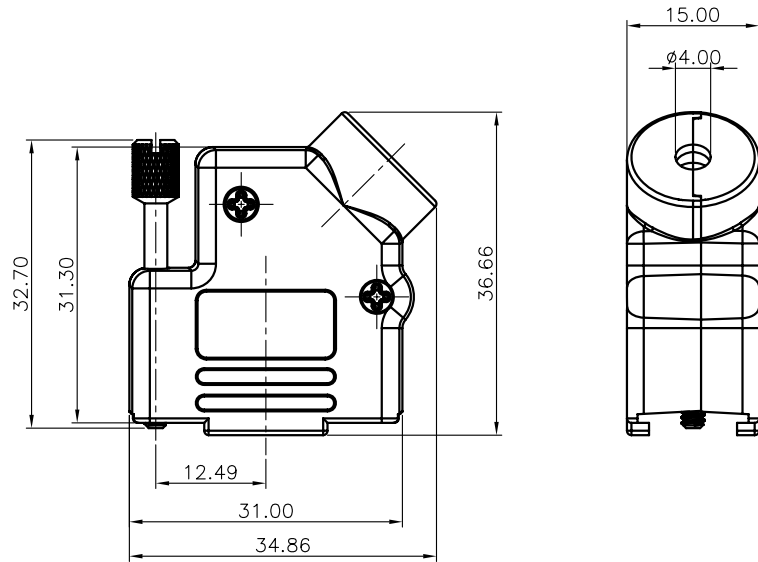

BOM LIST			
ITEM	PART NAME	Q'ty	NOTES
1	SCREW	2	M2
2	METAL HOOD-1	1	
3	BOLT	1	UNC#4-40
4	METAL HOOD-2	1	

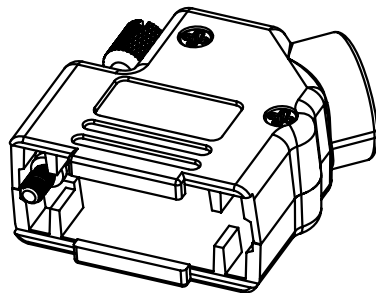

GENERAL TOLERANCE		ANGLE TOLERANCE		PROJECTION		TITLE	D-SUB 9pin Metal Hoods Large Angled Cable Outlet	
X.	±0.60	X.	±5°	UNITS	mm			
.X	±0.38	.X	±3°	SHEET SIZE	A4	SERIES	DS1047-04 SERIES	
.XX	±0.25	.XX	±2°	晨翔电子有限公司 CONNFLY CONNFLY ELECTRONIC CO. LTD				
DRAWING TYPE		COSTOMER						
SCALE	1:1	SHEET	1 OF 1					
DRAWING NO.		C-DS1047-04-09XX						

REV.	DESCRIPTION	DRAWN	CHECKED	APPROVED
A	NEW RELEASE	YCH 12/31/09'	~	

NOTES:

1. PART NUMBER CODE:
DS1047-04 - 15 X X

Packing type
1: Mix packing
2: Separation packing

Cover Material
M: Metal(Znic alloy)

Positions
15: 15pin

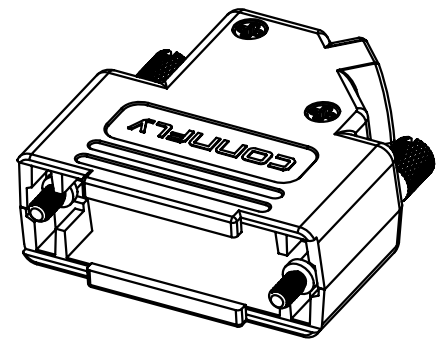
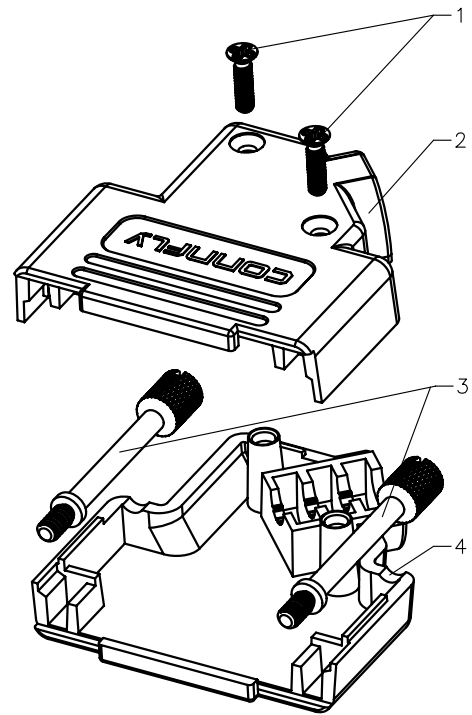
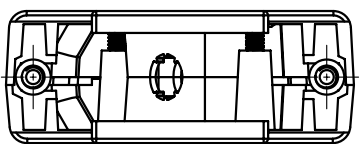
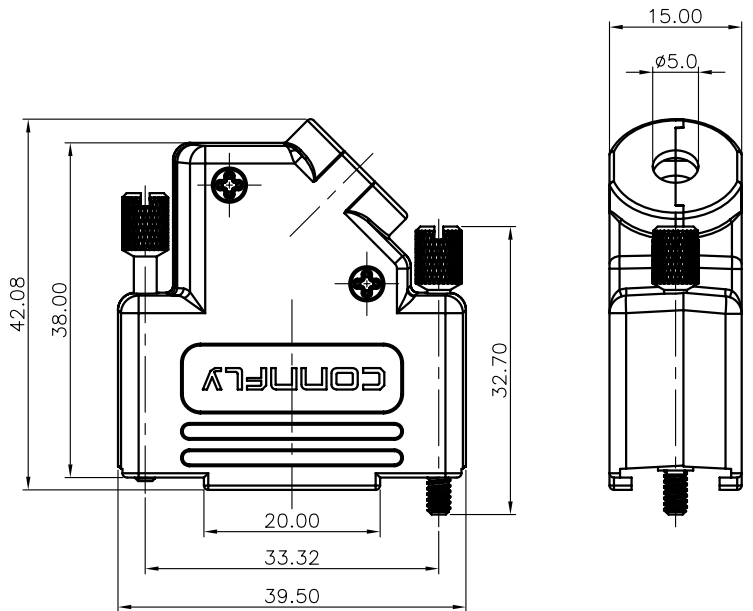

BOM LIST			
ITEM	PART NAME	Q'ty	NOTES
1	SCREW	2	M2
2	METAL HOOD-1	1	
3	BOLT	2	UNC#4-40
4	METAL HOOD-2	1	

GENERAL TOLERANCE		ANGLE TOLERANCE		PROJECTION		TITLE	D-SUB 15pin Metal Hoods Large Angled Cable Outlet	
X.	±0.60	X.	±5°	UNITS	mm			
.X	±0.38	.X	±3°	SHEET SIZE	A4	SERIES	DS1047-04	SERIES
.XX	±0.25	.XX	±2°	晨翔电子有限公司 CONNFLY CONNFLY ELECTRONIC CO. LTD				
DRAWING TYPE		COSTOMER						
SCALE		1:1	SHEET 1 OF 1					
DRAWING NO.		C-DS1047-04-15XX						

REV.	DESCRIPTION	DRAWN	CHECKED	APPROVED
A	NEW RELEASE	YCH 12/31/09'	~	

NOTES:

1. PART NUMBER CODE:
DS1047-04 - 25 X X

Packing type
1: Mix packing
2: Separation packing
Cover Material
M: Metal(Znic alloy)
Positions
25: 25pin

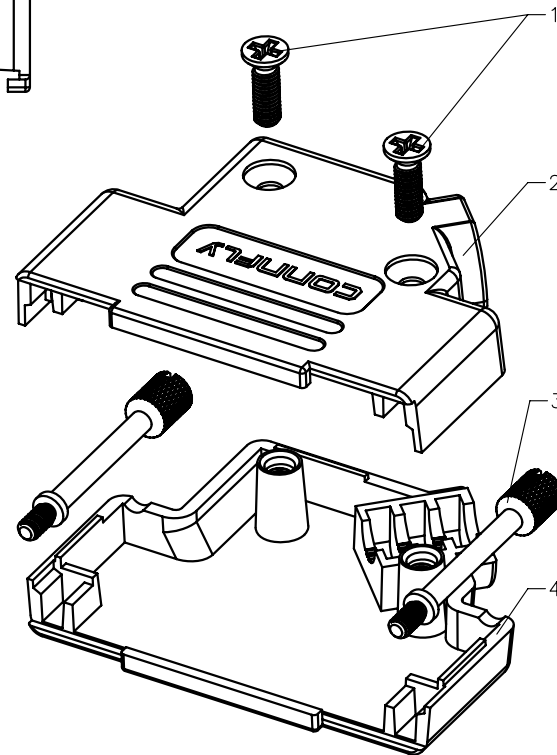
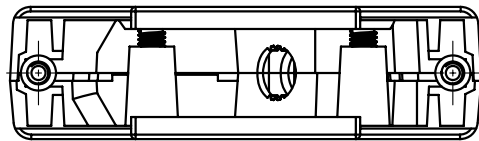
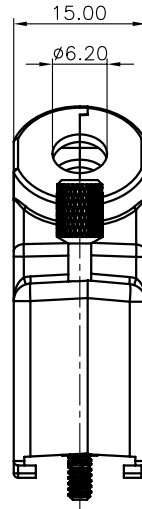
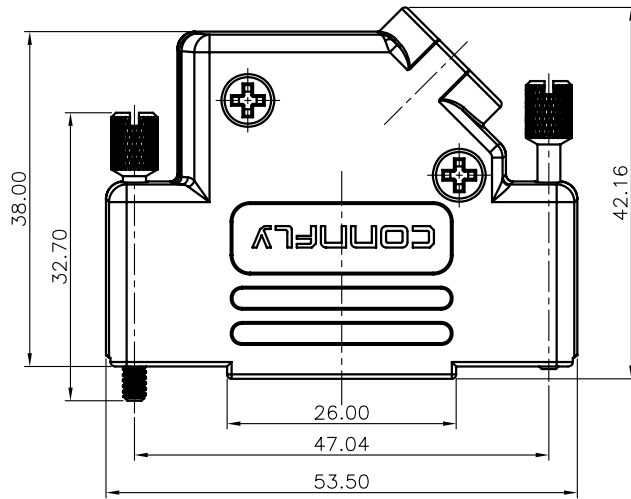

BOM LIST			
ITEM	PART NAME	Q'ty	NOTES
1	SCREW	2	M3
2	METAL HOOD-1	1	
3	BOLT	2	UNC#4-40
4	METAL HOOD-2	1	

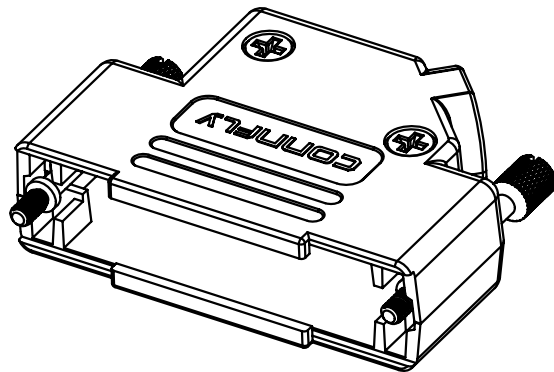

GENERAL TOLERANCE		ANGLE TOLERANCE		PROJECTION	TITLE
X.	± 0.60	X.	$\pm 5^\circ$		D-SUB 25pin Metal Hoods Large Angled Cable Outlet
.X	± 0.38	.X	$\pm 3^\circ$	mm	
.XX	± 0.25	.XX	$\pm 2^\circ$	A4	SERIES DS1047-04 SERIES
DRAWING TYPE		COSTOMER		晨翔电子有限公司 CONFLY CONNFLY ELECTRONIC CO. LTD	
SCALE		1:1	SHEET 1 OF 1		
DRAWING NO.		C-DS1047-04-25XX			

REV.	DESCRIPTION	DRAWN	CHECKED	APPROVED
A	NEW RELEASE	YCH 12/31/09'	~	

NOTES:

1. PART NUMBER CODE:
DS1047-04 - 37 X X

Packing type
1: Mix packing
2: Separation packing

Cover Material
M: Metal(Znic alloy)

Positions
37: 37pin

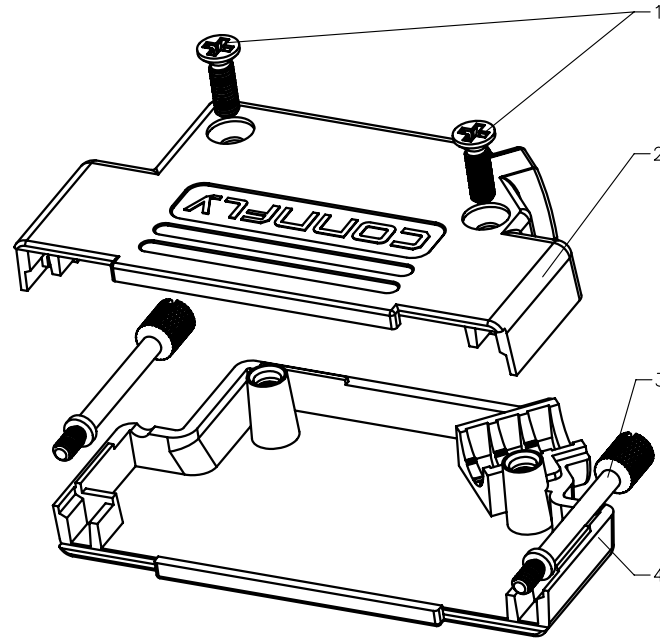
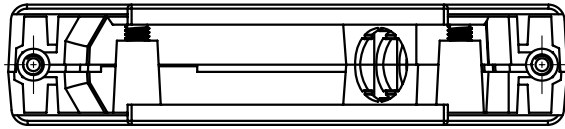
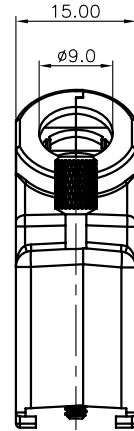
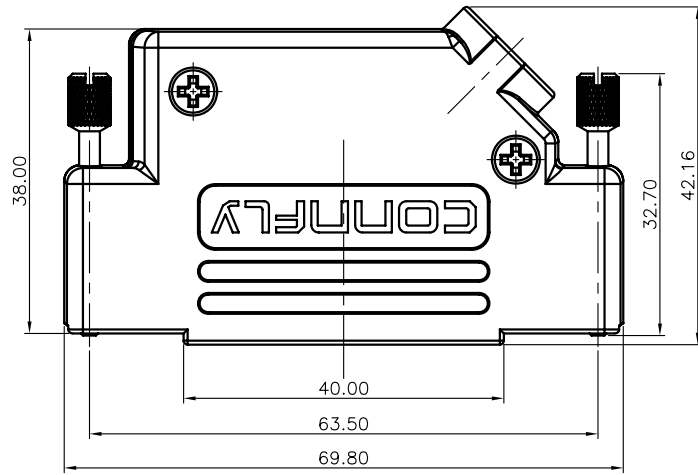

BOM LIST			
ITEM	PART NAME	Q'ty	NOTES
1	SCREW	2	M3
2	METAL HOOD-1	1	
3	BOLT	2	UNC#4-40
4	METAL HOOD-2	1	

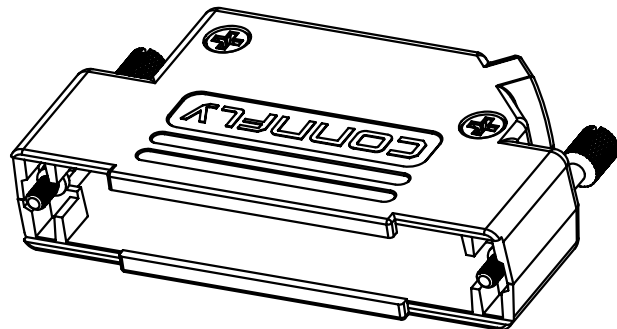

GENERAL TOLERANCE		ANGLE TOLERANCE		PROJECTION	TITLE	D-SUB 37pin Metal Hoods Large Angled Cable Outlet	
X.	±0.60	X.	±5°	mm			
.X	±0.38	.X	±3°	A4	SERIES	DS1047-04 SERIES	
.XX	±0.25	.XX	±2°				
DRAWING TYPE		COSTOMER		 晨翔电子有限公司 CONNFLY CONNFLY ELECTRONIC CO. LTD			
SCALE		1:1	SHEET 1 OF 1				
DRAWING NO.		C-DS1047-04-37XX					

REV.	DESCRIPTION	DRAWN	CHECKED	APPROVED
A	NEW RELEASE	YCH 04/13/11'	~	

ØF
Ø4.0
Ø5.0
Ø7.0
Ø9.0

NOTES:

1. METAL HOOD MATERIAL: Znic alloy

2. PART NUMBER CODE:

DS1047-06 - 09 X X

- X — Packing type
1: Mix packing
- X — Cover Material
M: Metal(Znic alloy)
- 09 — Positions
09: 9pin

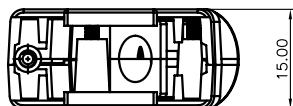
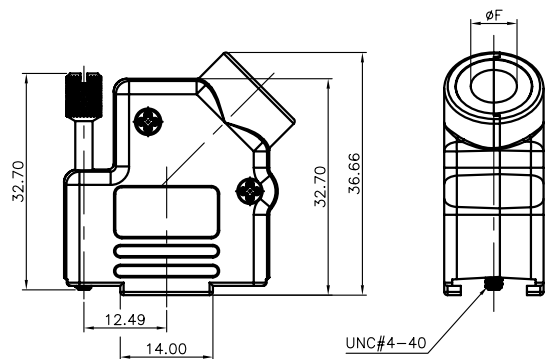

BOM LIST			
ITEM	PART NAME	Q'ty	NOTES
1	SCREW	2	M3
2	UP METAL HOOD	1	Znic alloy
3	SR	2	
4	LONG BOLT	1	UNC 4-40
5	DOWN METAL HOOD	1	Znic alloy

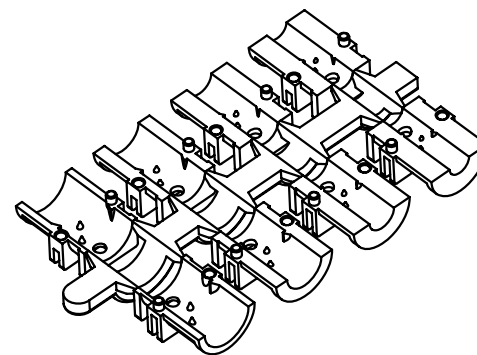
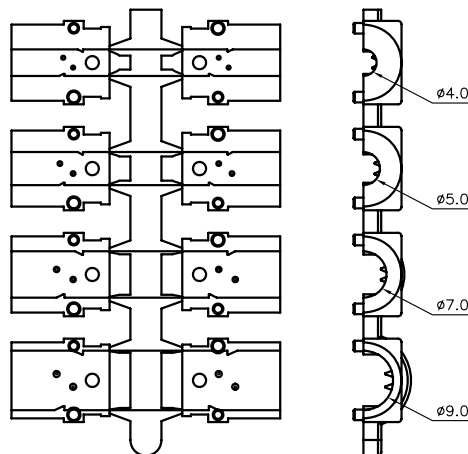
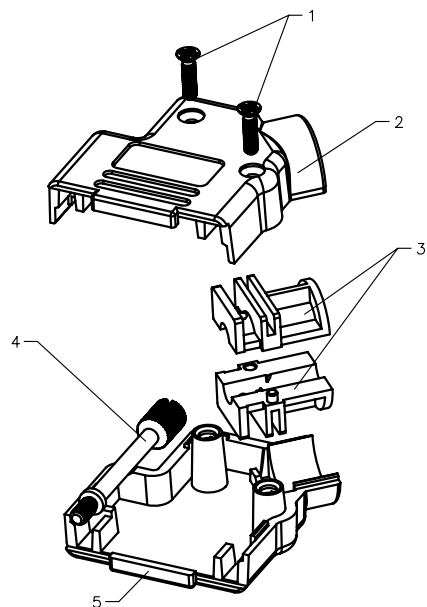

GENERAL TOLERANCE	ANGLE TOLERANCE	PROJECTION		TITLE	D-SUB 09pin Metal Hoods Large Angled Cable Outlet
X. ±0.60	X. ±5°	UNITS	mm	SERIES	DS1047-06 SERIES
.X ±0.38	.X ±3°	SHEET SIZE	A4		
.XX ±0.25	.XX ±2°				
DRAWING TYPE	COSTOMER				
SCALE	1:1	SHEET	1 OF 1		
DRAWING NO.	C-DS1047-06-09XX-A				

晨翔电子有限公司
CONNFLY CONNFLY ELECTRONIC CO. LTD

REV.	DESCRIPTION	DRAWN	CHECKED	APPROVED
A	NEW RELEASE	YCH 04/13/11'	~	

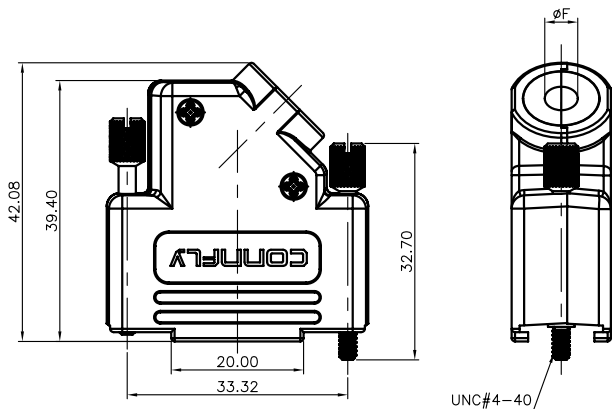

ϕF
$\phi 4.0$
$\phi 5.0$
$\phi 7.0$
$\phi 9.0$

NOTES:

1. METAL HOOD MATERIAL: Znic alloy

2. PART NUMBER CODE:

DS1047-06 - 15 X X

Packing type
1: Mix packing

Cover Material
M: Metal(Znic alloy)

Positions
15: 15pin

BOM LIST			
ITEM	PART NAME	Q'ty	NOTES
1	SCREW	2	M3
2	UP METAL HOOD	1	Znic alloy
3	SR	2	
4	LONG BOLT	2	UNC 4-40
5	DOWN METAL HOOD	1	Znic alloy

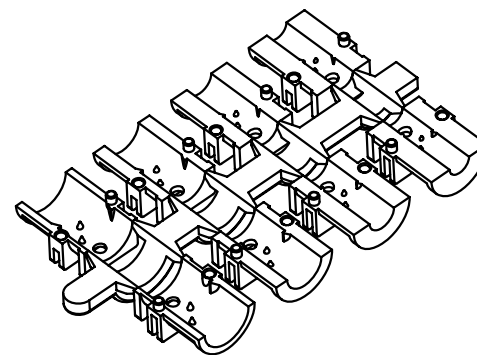
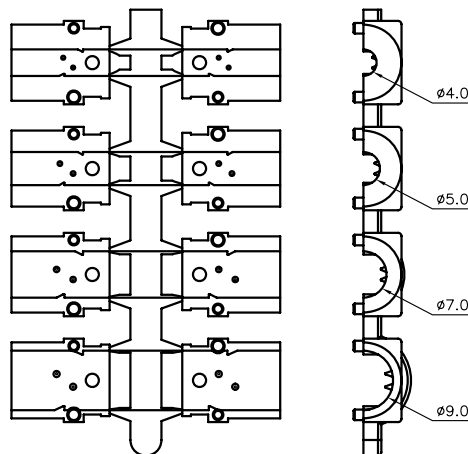
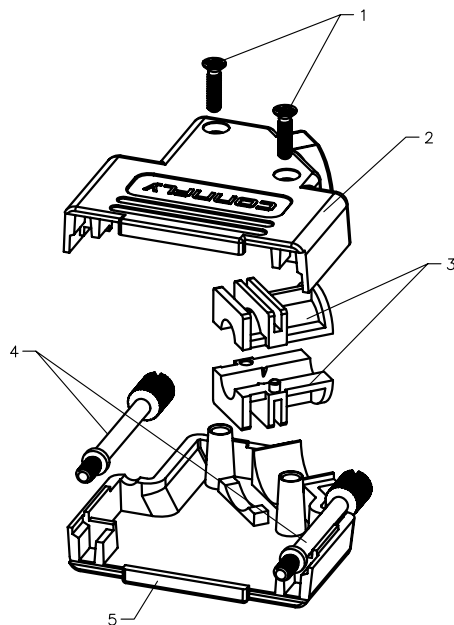
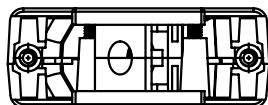

GENERAL TOLERANCE		ANGLE TOLERANCE		PROJECTION	TITLE	D-SUB 15pin Metal Hoods Large Angled Cable Outlet	
X.	± 0.60	X.	$\pm 5^\circ$		mm		
.X	± 0.38	.X	$\pm 3^\circ$				
.XX	± 0.25	.XX	$\pm 2^\circ$				
DRAWING TYPE		COSTOMER		SHEET SIZE	A4	SERIES	DS1047-06 SERIES
SCALE		1:1		SHEET		1 OF 1	
DRAWING NO.		C-DS1047-06-15XX-A					

晨翔电子有限公司
CONNFLY CONNFLY ELECTRONIC CO. LTD

REV.	DESCRIPTION	DRAWN	CHECKED	APPROVED
A	NEW RELEASE	YCH 04/13/11'	~	

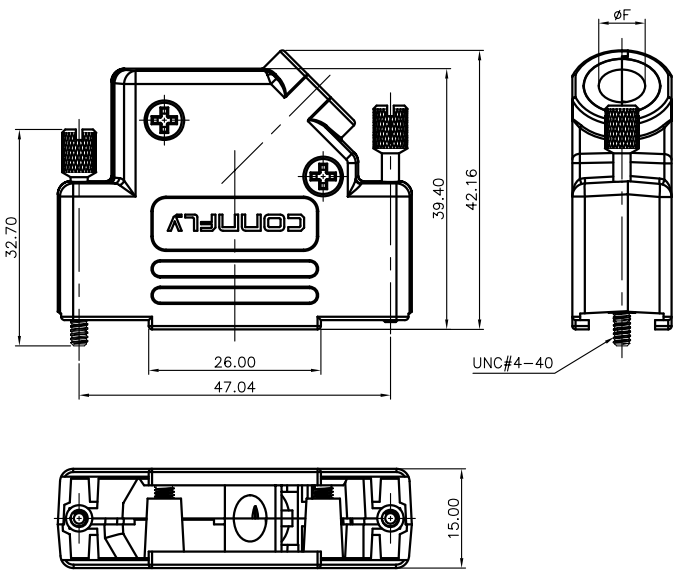

øF
ø4.0
ø5.0
ø7.0
ø9.0

BOM LIST			
ITEM	PART NAME	Q'ty	NOTES
1	SCREW	2	M3
2	UP METAL HOOD	1	Znic alloy
3	SR	2	
4	LONG BOLT	2	UNC 4-40
5	DOWN METAL HOOD	1	Znic alloy

NOTES:

1. METAL HOOD MATERIAL: Znic alloy

2. PART NUMBER CODE:

DS1047-06 - 25 X X

Packing type
1: Mix packing

Cover Material
M: Metal(Znic alloy)

Positions
25: 25pin

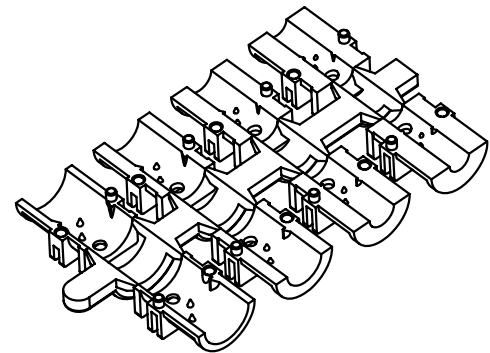
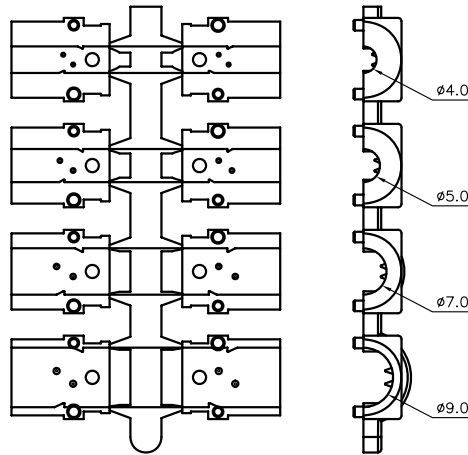
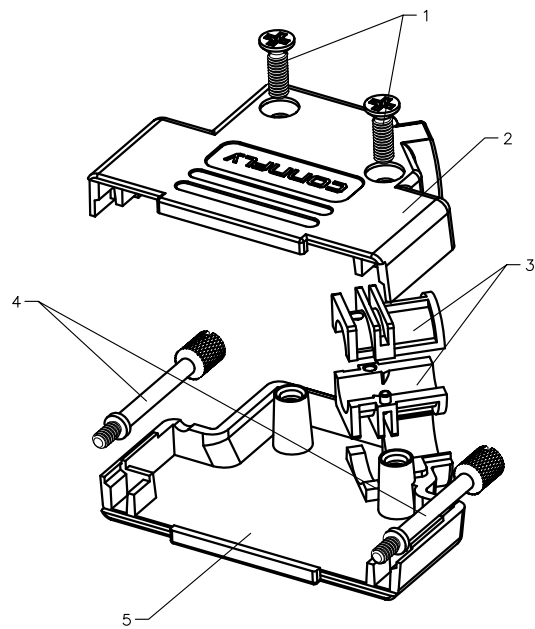

GENERAL TOLERANCE		ANGLE TOLERANCE		PROJECTION	TITLE	D-SUB 25pin Metal Hoods Large Angled Cable Outlet	
X.	±0.60	X.	±5°	mm			
.X	±0.38	.X	±3°	A4	SERIES	DS1047-06 SERIES	
.XX	±0.25	.XX	±2°	 晨翔电子有限公司 CONNFLY CONNFLY ELECTRONIC CO. LTD			
DRAWING TYPE		COSTOMER					
SCALE		1:1 SHEET 1 OF 1					
DRAWING NO.		C-DS1047-06-25XX-A					

REV.	DESCRIPTION	DRAWN	CHECKED	APPROVED
A	NEW RELEASE	YCH 04/13/11'	~	

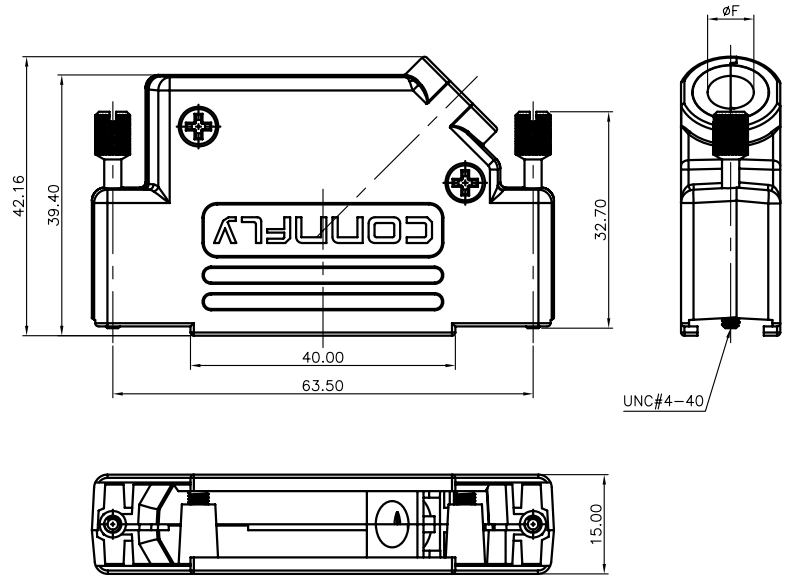

øF
ø4.0
ø5.0
ø7.0
ø9.0

BOM LIST			
ITEM	PART NAME	Q'ty	NOTES
1	SCREW	2	M3
2	UP METAL HOOD	1	Znic alloy
3	SR	2	
4	LONG BOLT	2	UNC 4-40
5	DOWN METAL HOOD	1	Znic alloy

NOTES:

- METAL HOOD MATERIAL: Znic alloy
- PART NUMBER CODE:
DS1047-06 - 37 X X
 - X: Packing type
1: Mix packing
 - X: Cover Material
M: Metal(Znic alloy)
 - 37: Positions
37: 37pin

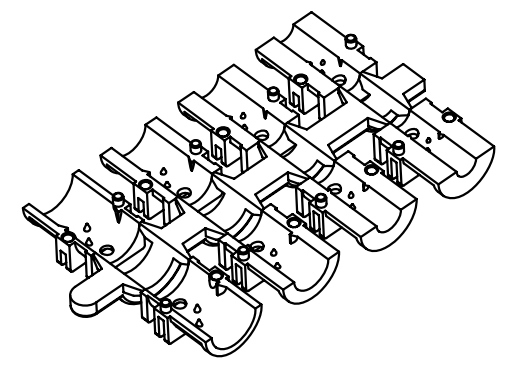
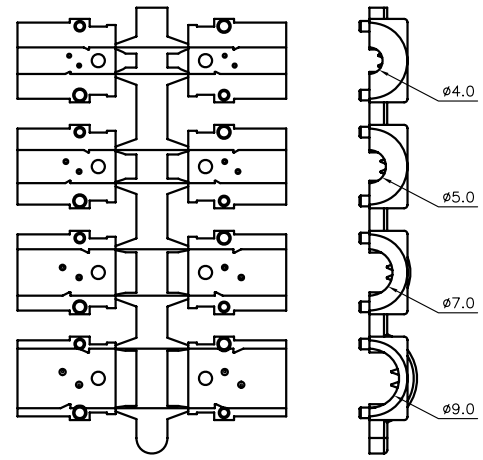
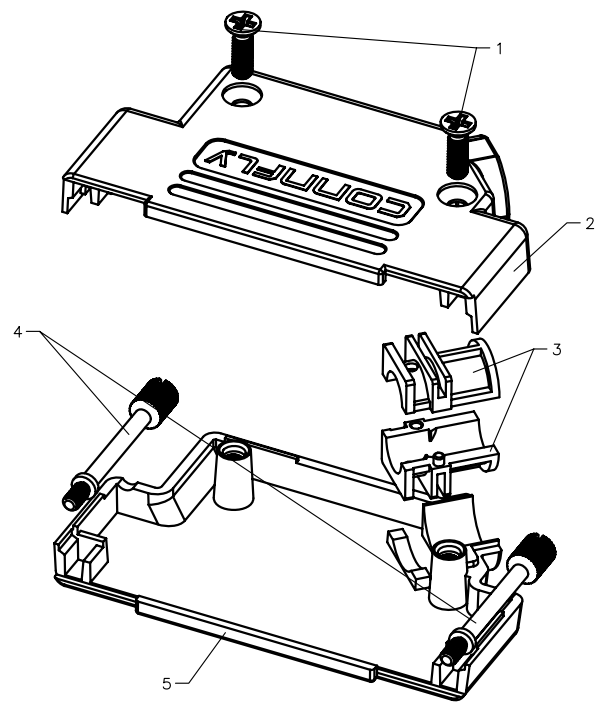

GENERAL TOLERANCE	ANGLE TOLERANCE	PROJECTION		TITLE	D-SUB 37pin Metal Hoods Large Angled Cable Outlet		
X. ±0.60	X. ±5°	UNITS	mm				
.X ±0.38	.X ±3°	SHEET SIZE	A4	SERIES	DS1047-06	SERIES	
.XX ±0.25	.XX ±2°	晨翔电子有限公司 CONNFLY CONNFLY ELECTRONIC CO. LTD					
DRAWING TYPE	CUSTOMER						
SCALE	1:1						SHEET 1 OF 1
DRAWING NO.	C-DS1047-06-37XX-A						

REV.	DESCRIPTION	DRAWN	CHECKED	APPROVED
A	NEW RELEASE	YCH 03/31/11'	~	

NOTES:

- METAL HOOD MATERIAL: Zinc alloy
- PART NUMBER CODE:
DS1047-01 - 09 X X
 - Packing type
1: Mix packing
2: Separation packing
 - Cover Material
M: Metal(Znic alloy)
 - Positions
09: 9pin

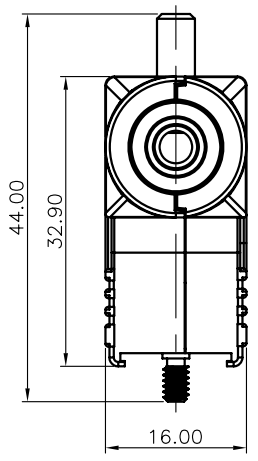
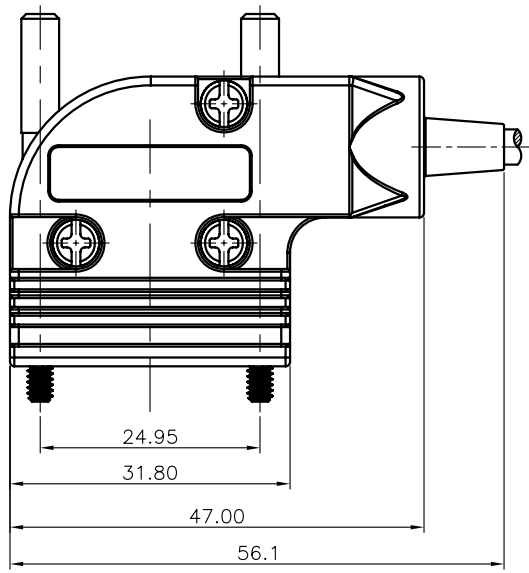

øF	ø4.0
	ø5.0
	ø7.0
	ø9.0

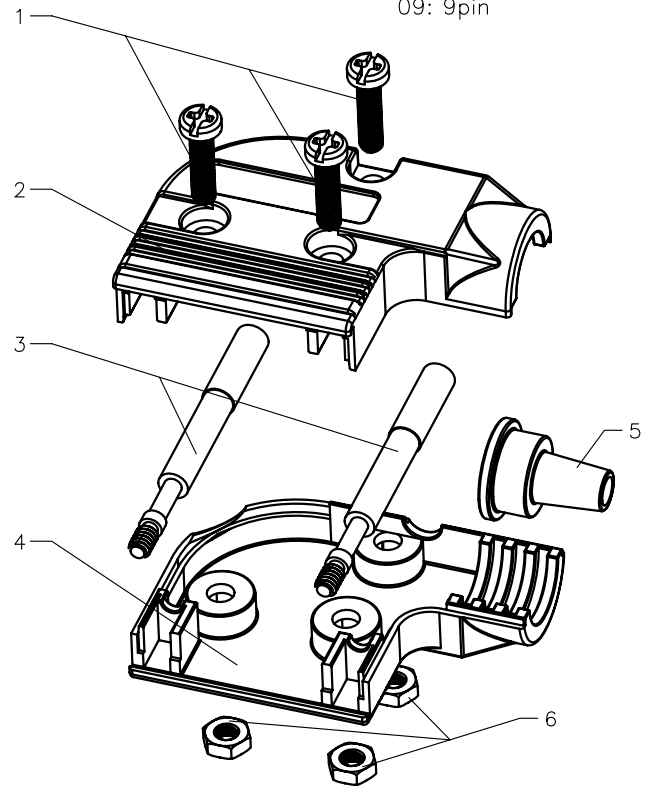
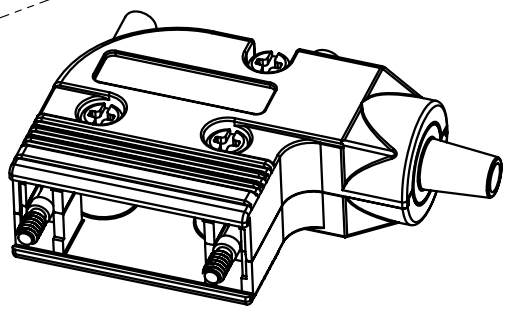
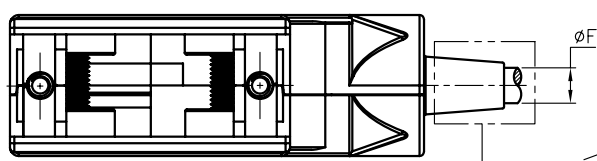
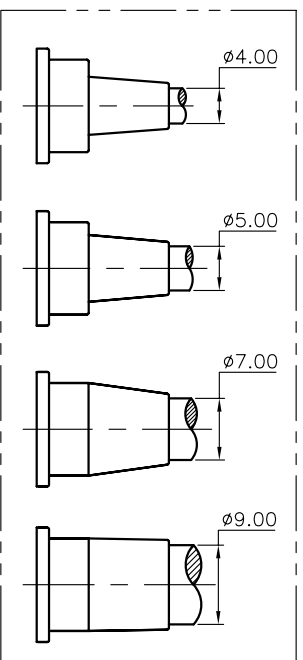

BOM LIST			
ITEM	PART NAME	Q'ty	NOTES
1	SCREW	3	M3
2	UP METAL HOOD	1	Znic alloy
3	LONG BOLT	2	UNC 4-40
4	DOWN METAL HOOD	1	Znic alloy
5	SR	4	
6	NUT	3	M3

GENERAL TOLERANCE	ANGLE TOLERANCE	PROJECTION	TITLE
X. ±0.60	X. ±5°	UNITS	D-SUB 9pin Metal Cover
.X ±0.38	.X ±3°	SHEET SIZE	90° type
.XX ±0.25	.XX ±2°		SERIES DS1047-01 SERIES
DRAWING TYPE	COSTOMER	 晨翔电子有限公司 CONNFLY CONNFLY ELECTRONIC CO. LTD	
SCALE	1:1 SHEET 1 OF 1		
DRAWING NO.	C-DS1047-01-09XX-A		

REV.	DESCRIPTION	DRAWN	CHECKED	APPROVED
A	NEW RELEASE	YCH 03/31/11'	~	

NOTES:

1. METAL HOOD MATERIAL: Zinc alloy

2. PART NUMBER CODE:

DS1047-01 - 15 X X

Packing type
1: Mix packing
2: Separation packing

Cover Material
M: Metal(Zinc alloy)

Positions
15: 15pin

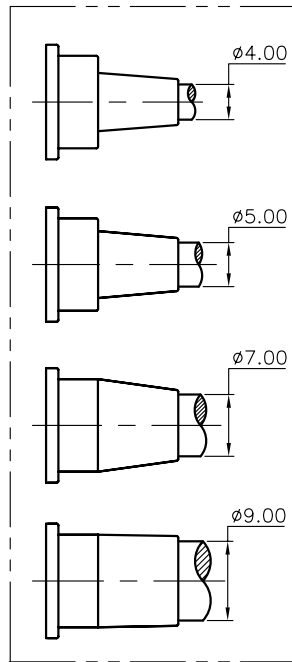
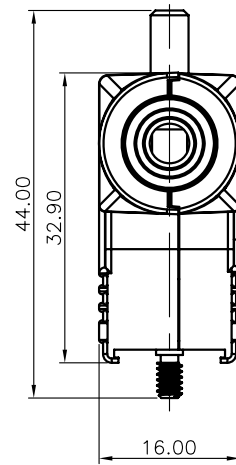
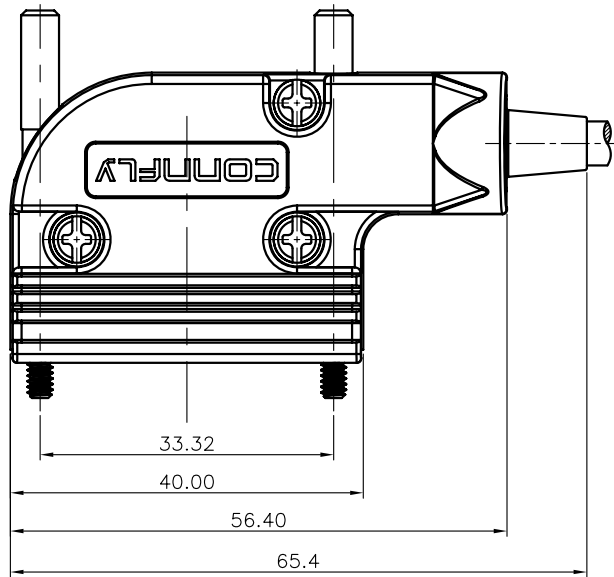

ϕF	
	$\phi 4.0$
	$\phi 5.0$
	$\phi 7.0$
	$\phi 9.0$

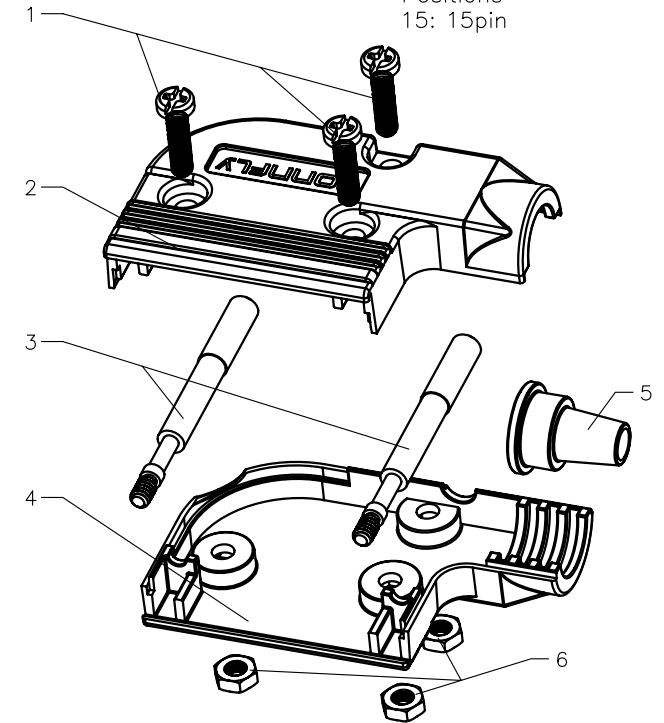
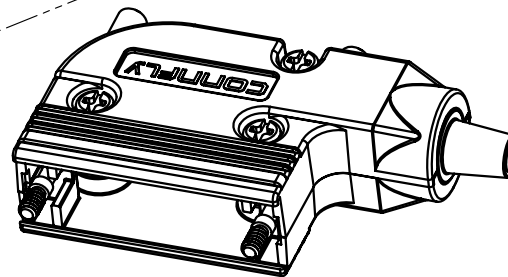
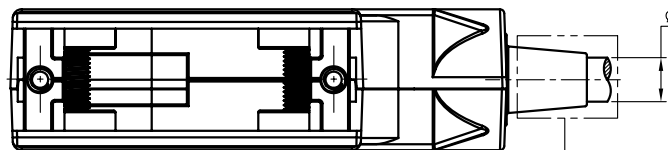

BOM LIST			
ITEM	PART NAME	Q'ty	NOTES
1	SCREW	3	M3
2	UP METAL HOOD	1	Znic alloy
3	LONG BOLT	2	UNC 4-40
4	DOWN METAL HOOD	1	Znic alloy
5	SR	4	
6	NUT	3	M3

GENERAL TOLERANCE	ANGLE TOLERANCE
X. ± 0.60	X. $\pm 5^\circ$
.X ± 0.38	.X $\pm 3^\circ$
.XX ± 0.25	.XX $\pm 2^\circ$

PROJECTION	TITLE
	D-SUB 15pin Metal Cover 90° type
UNITS	mm
SHEET SIZE	A4
SERIES	DS1047-01 SERIES

DRAWING TYPE	COSTOMER
SCALE	1:1 SHEET 1 OF 1
DRAWING NO.	C-DS1047-01-15XX-A

晨翔电子有限公司
CONNFly CONNFly ELECTRONIC CO. LTD

REV.	DESCRIPTION	DRAWN	CHECKED	APPROVED
A	NEW RELEASE	YCH 03/31/11'	~	

NOTES:

1. METAL HOOD MATERIAL: Zinc alloy

2. PART NUMBER CODE:

DS1047-01 - 25 X X

Packing type
1: Mix packing
2: Separation packing

Cover Material
M: Metal(Zinc alloy)

Positions
25: 25pin

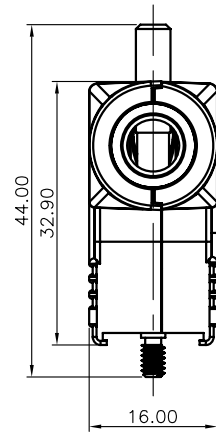
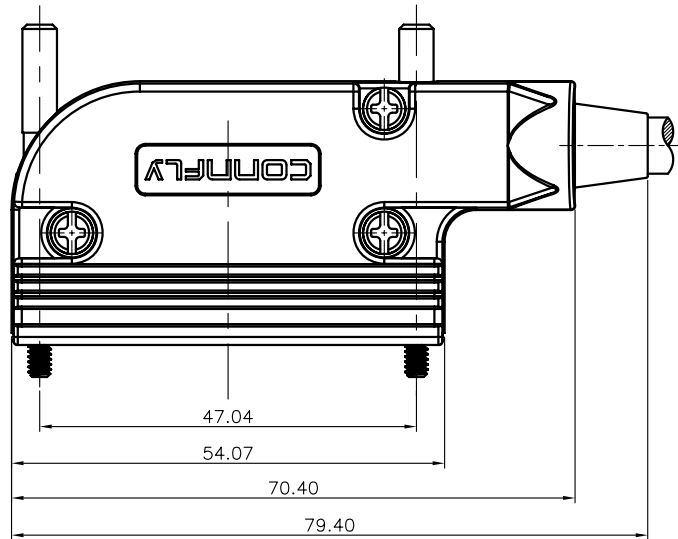

ØF	Ø
	Ø4.0
	Ø5.0
	Ø7.0
	Ø9.0

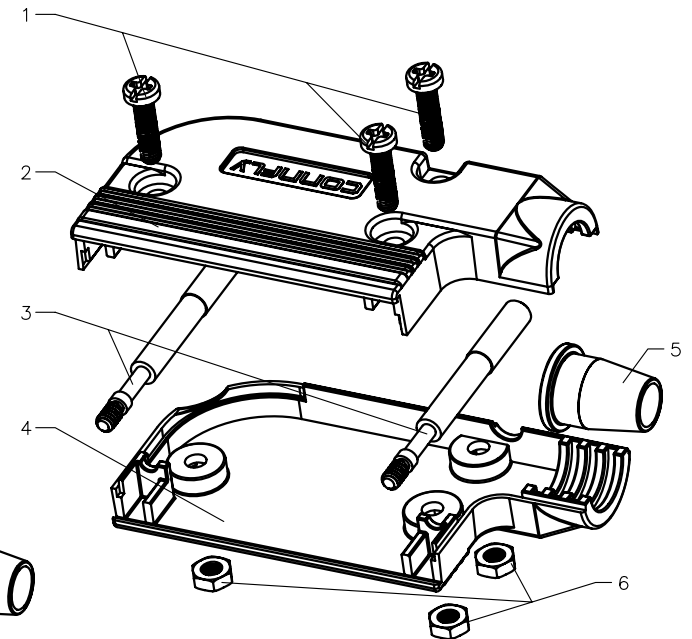
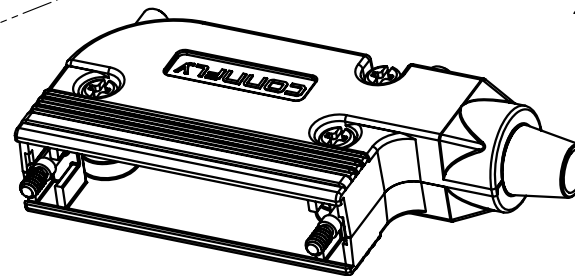
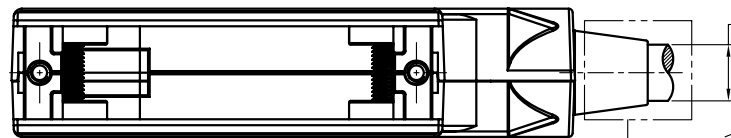
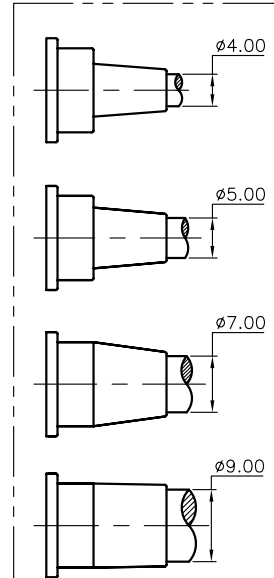

BOM LIST			
ITEM	PART NAME	Q'ty	NOTES
1	SCREW	3	M3
2	UP METAL HOOD	1	Znic alloy
3	LONG BOLT	2	UNC 4-40
4	DOWN METAL HOOD	1	Znic alloy
5	SR	4	
6	NUT	3	M3

GENERAL TOLERANCE	ANGLE TOLERANCE
X. ±0.60	X. ±5°
.X ±0.38	.X ±3°
.XX ±0.25	.XX ±2°

PROJECTION	TITLE	D-SUB 25pin Metal Cover 90° type	
UNITS	mm	SERIES	DS1047-01 SERIES
SHEET SIZE	A4		

DRAWING TYPE	CUSTOMER		
SCALE	1:1	SHEET	1 OF 1
DRAWING NO.	C-DS1047-01-25XX-A		

 晨翔电子有限公司
CONNFLY CONNFLY ELECTRONIC CO. LTD

REV.	DESCRIPTION	DRAWN	CHECKED	APPROVED
A	NEW RELEASE	YCH 03/31/11'	~	

NOTES:

1. METAL HOOD MATERIAL: Zinc alloy

2. PART NUMBER CODE:

DS1047-01 - 37 X X

Packing type
1: Mix packing
2: Separation packing

Cover Material
M: Metal(Znic alloy)

Positions
37: 37pin

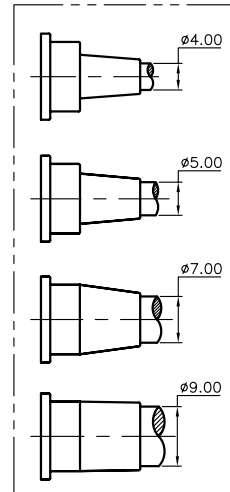
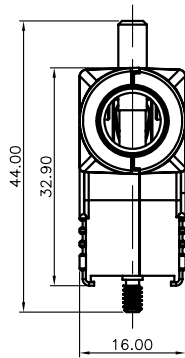
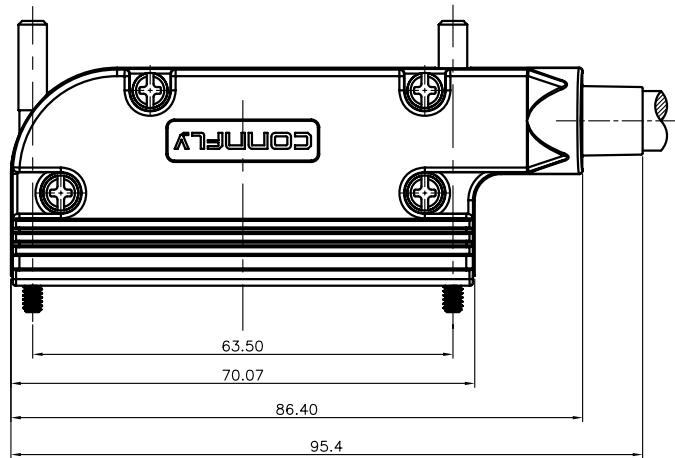

ϕF	
	$\phi 4.0$
	$\phi 5.0$
	$\phi 7.0$
	$\phi 9.0$

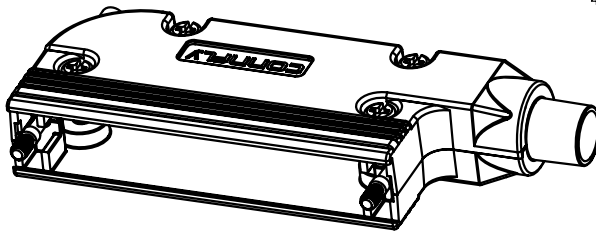
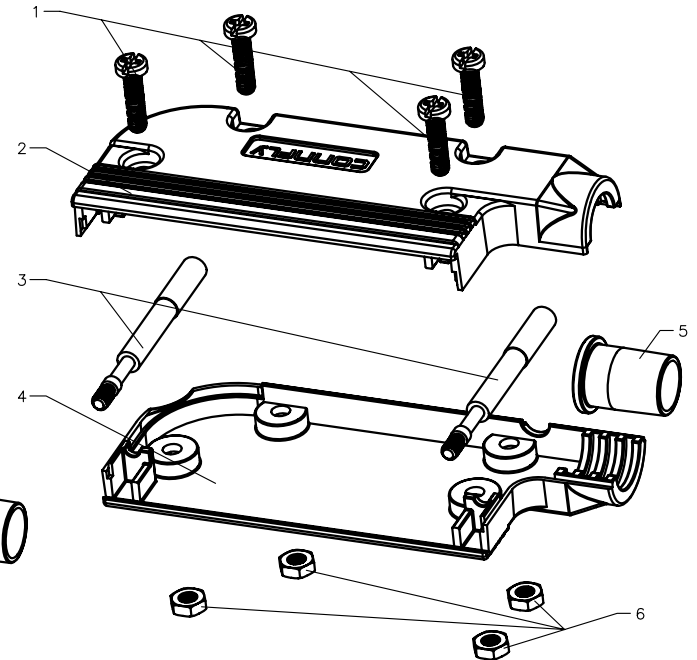
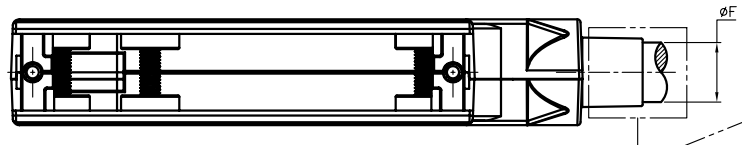

BOM LIST			
ITEM	PART NAME	Q'ty	NOTES
1	SCREW	4	M3
2	UP METAL HOOD	1	Znic alloy
3	LONG BOLT	2	UNC 4-40
4	DOWN METAL HOOD	1	Znic alloy
5	SR	4	
6	NUT	4	M3

GENERAL TOLERANCE		ANGLE TOLERANCE	
X.	± 0.60	X.	$\pm 5^\circ$
.X	± 0.38	.X	$\pm 3^\circ$
.XX	± 0.25	.XX	$\pm 2^\circ$

PROJECTION	TITLE	D-SUB 37pin Metal Cover 90° type	
UNITS	mm		
SHEET SIZE	A4	SERIES	DS1047-01 SERIES

DRAWING TYPE	CUSTOMER		
SCALE	1:1	SHEET	1 OF 1
DRAWING NO.	C-DS1047-01-37XX-A		

 晨翔电子有限公司
CONNFLY CONNFLY ELECTRONIC CO. LTD

	ϕF
W/ SR	$\phi 6.5$
W/O SR	$\phi 3.0 \sim \phi 9.5$

REV.	DESCRIPTION	DRAWN	CHECKED	APPROVED
A	NEW RELEASE	YCH 03/22/11'	~	

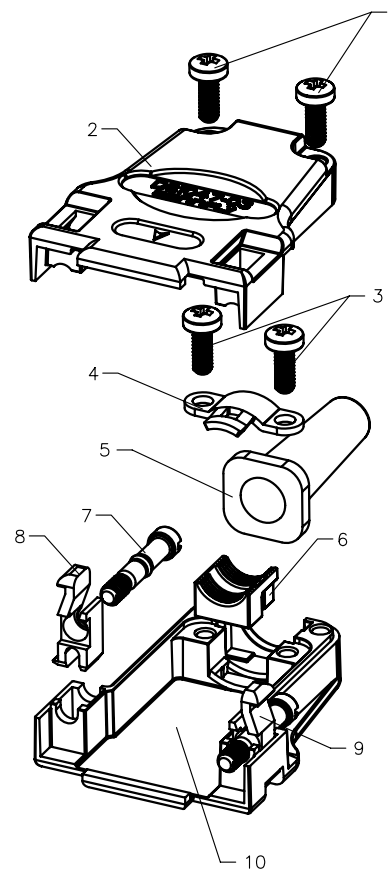
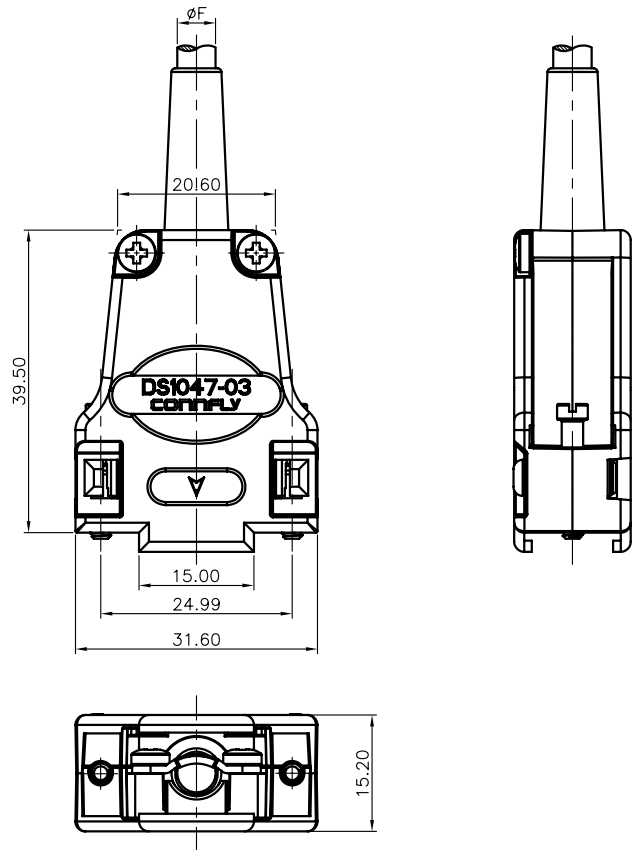

NOTES:

1. PART NUMBER CODE:

DS1047-03 - 09 X X X

- SR Support
- S: W/ SR
- X: W/O SR
- Packing type
- 1: Mix packing
- 2: Separation packing
- Cover Material
- M: Metal(Znic alloy)
- Positions
- 09: 9pin

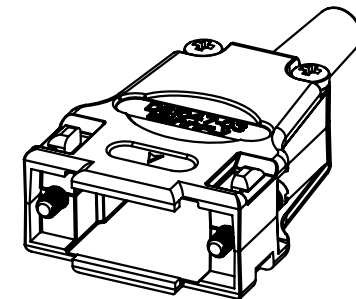

BOM LIST			
ITEM	PART NAME	Q'ty	NOTES
1	SCREW M2.5*8	2	M2.5
2	METAL HOOD-1	1	Znic alloy
3	SCREW M2.5*6	2	M2.5
4	WASHER	1	
5	SR	1	
6	STRAIN RELIEF	1	
7	BOLT	2	UNC 4-40
8	LATCH-1	1	
9	LATCH-2	1	
10	METAL HOOD-2	1	Znic alloy

GENERAL TOLERANCE	ANGLE TOLERANCE	PROJECTION		TITLE	D-SUB 9pin Metal Hoods	
X. ± 0.60	X. $\pm 5^\circ$	UNITS	mm		Straight Cable Outlet Type	
.X ± 0.38	.X $\pm 3^\circ$	SHEET SIZE	A4	SERIES	DS1047-03 SERIES	
.XX ± 0.25	.XX $\pm 2^\circ$					
DRAWING TYPE	COSTOMER		晨翔电子有限公司 CONNPLY CONNPLY ELECTRONIC CO. LTD			
SCALE	1:1	SHEET				1 OF 1
DRAWING NO.	C-DS1047-03-09XXX					

φF		
TYPE A	W/ SR	φ6.5
	W/O SR	φ3.0~φ9.5
TYPE B	W/ SR	φ9.0
	W/O SR	φ8.5~φ12.5

REV.	DESCRIPTION	DRAWN	CHECKED	APPROVED
A	NEW RELEASE	YCH 03/22/11'	~	

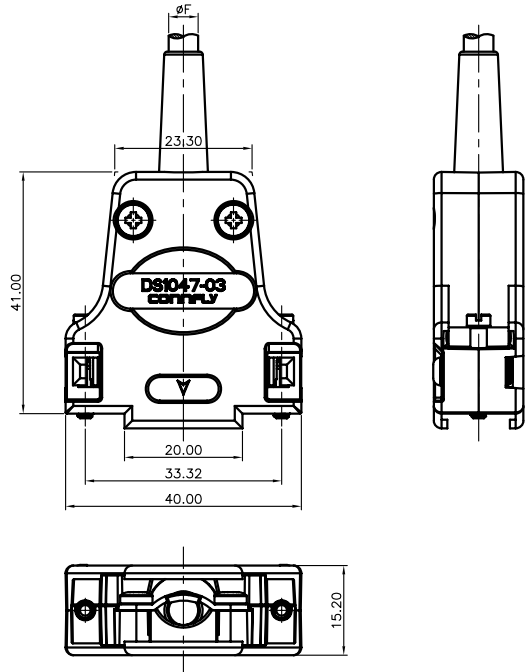

NOTES:

1. PART NUMBER CODE:

DS1047-03 - 15 X X X X

- SR Support
- S: W/ SR
- X: W/O SR
- Type Support
- A: Type A
- B: Type B
- Packing type
- 1: Mix packing
- 2: Separation packing
- Cover Material
- M: Metal(Znic alloy)
- Positions
- 15: 15pin

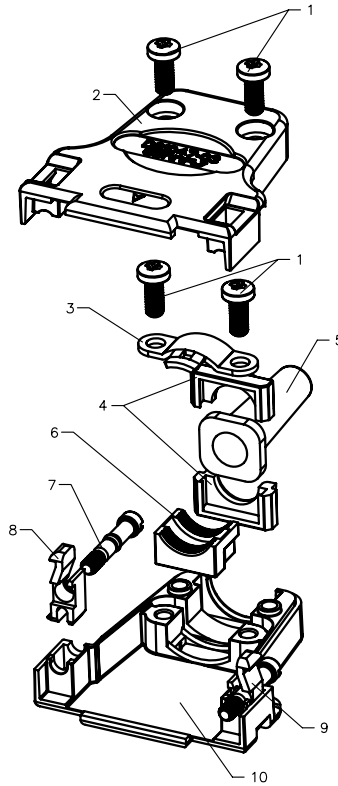

TYPE A

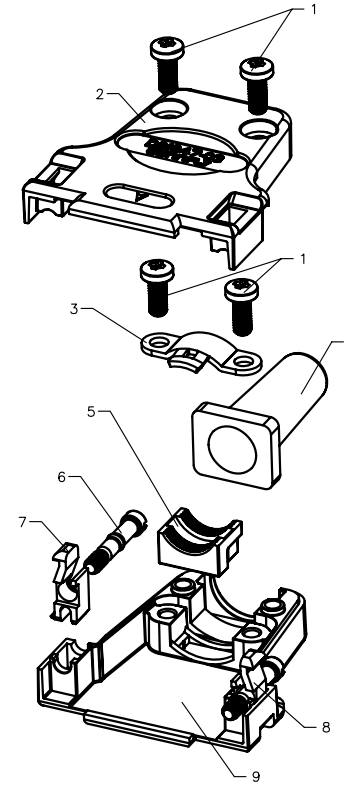

TYPE B

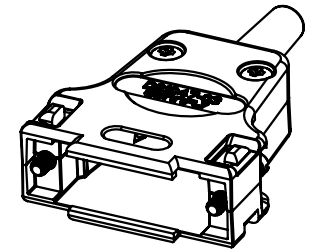

TYPE A BOM LIST			
ITEM	PART NAME	Q'ty	NOTES
1	SCREW	4	M3
2	METAL HOOD-1	1	Znic alloy
3	WASHER	1	
4	CABLE REDUCTION PLATE	2	
5	SR	1	
6	STRAIN RELIEF	1	
7	BOLT	2	UNC 4-40
8	LATCH-1	1	
9	LATCH-2	1	
10	METAL HOOD-2	1	Znic alloy

TYPE B BOM LIST			
ITEM	PART NAME	Q'ty	NOTES
1	SCREW	4	M3
2	METAL HOOD-1	1	Znic alloy
3	WASHER	1	
4	SR	1	
5	STRAIN RELIEF	1	
6	BOLT	2	UNC 4-40
7	LATCH-1	1	
8	LATCH-2	1	
9	METAL HOOD-2	1	Znic alloy

GENERAL TOLERANCE		ANGLE TOLERANCE		PROJECTION	TITLE
X.	±0.60	X.	±5°		D-SUB 15pin Metal Hoods Straight Cable Outlet Type
.X	±0.38	.X	±3°	mm	
.XX	±0.25	.XX	±2°	A4	
DRAWING TYPE				CUSTOMER	
SCALE		1:1	SHEET		1 OF 1
DRAWING NO.		C-DS1047-03-15XXXX			
晨翔电子有限公司 CONNFLY CONNFLY ELECTRONIC CO. LTD					

REV.	DESCRIPTION	DRAWN	CHECKED	APPROVED
A	NEW RELEASE	YCH 03/22/11'	~	

	øF	
TYPE A	W/ SR	ø8
	W/O SR	ø3.0~ø8.5
TYPE B	W/ SR	ø9.0
	W/O SR	ø8.5~ø12.5

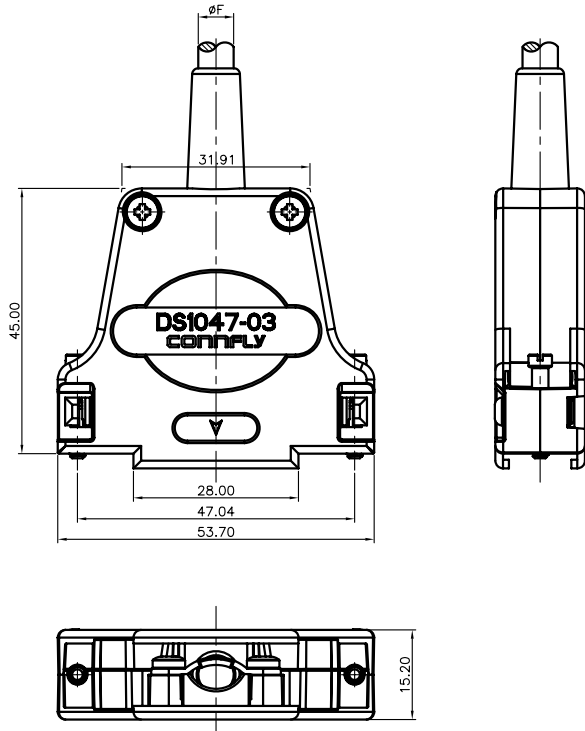

NOTES:
 1. PART NUMBER CODE:
 DS1047-03 - 25 X X X X

- SR Support
- S: W/ SR
- X: W/O SR
- Type Support
- A: Type A
- B: Type B
- Packing type
- 1: Mix packing
- 2: Separation packing
- Cover Material
- M: Metal(Znic alloy)
- Positions
- 25: 25pin

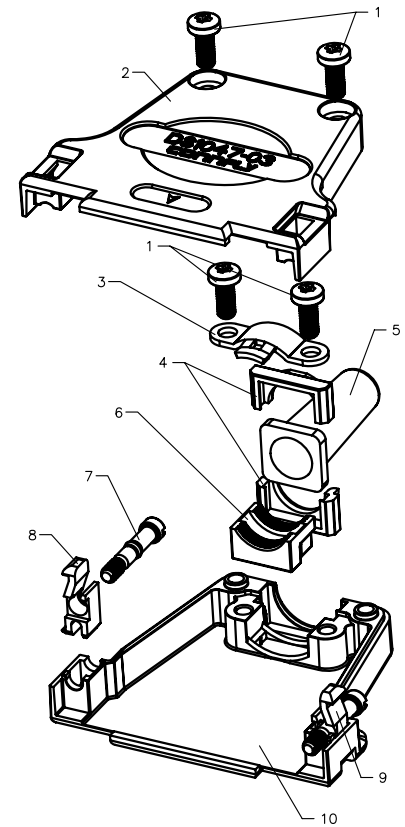

TYPE A

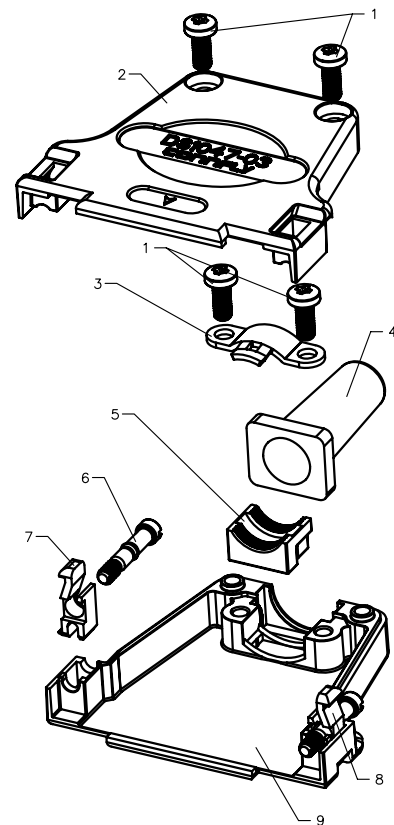

TYPE B

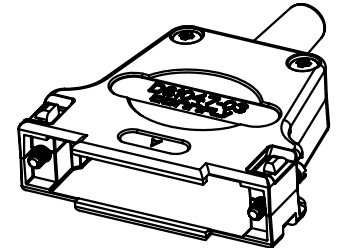

ITEM	PART NAME	Q'ty	NOTES
1	SCREW	4	M3
2	METAL HOOD-1	1	Znic alloy
3	WASHER	1	
4	CABLE REDUCTION PLATE	2	
5	SR	1	
6	STRAIN RELIEF	1	
7	BOLT	2	UNC 4-40
8	LATCH-1	1	
9	LATCH-2	1	
10	METAL HOOD-2	1	Znic alloy

ITEM	PART NAME	Q'ty	NOTES
1	SCREW	4	M3
2	METAL HOOD-1	1	Znic alloy
3	WASHER	1	
4	SR	1	
5	STRAIN RELIEF	1	
6	BOLT	2	UNC 4-40
7	LATCH-1	1	
8	LATCH-2	1	
9	METAL HOOD-2	1	Znic alloy

GENERAL TOLERANCE	ANGLE TOLERANCE	PROJECTION	TITLE
X. ±0.60	X. ±5°	mm	D-SUB 25pin Metal Hoods Straight Cable Outlet Type
.X ±0.38	.X ±3°	A4	SERIES DS1047-03 SERIES
.XX ±0.25	.XX ±2°		
DRAWING TYPE	COSTOMER	 晨翔电子有限公司 CONNPLY ELECTRONIC CO. LTD	
SCALE	1:1 SHEET 1 OF 1		
DRAWING NO.	C-DS1047-03-25XXXX		

	φF	
TYPE A	W/ SR	φ9
	W/O SR	φ3.0~φ12.0
TYPE B	W/ SR	φ11.5
	W/O SR	φ12.0~φ15.0

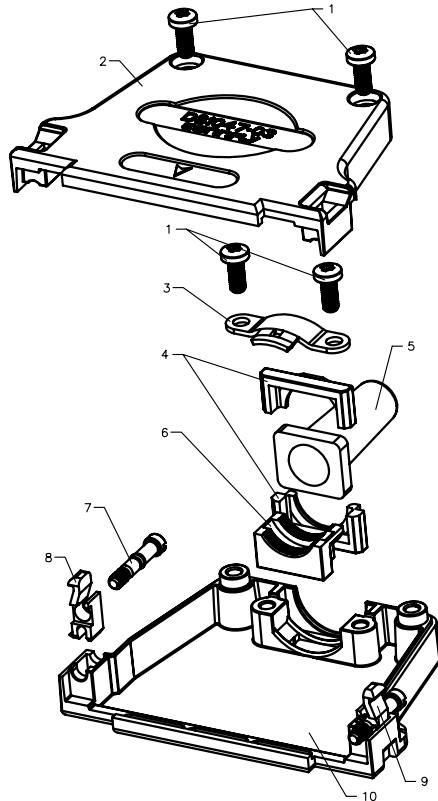
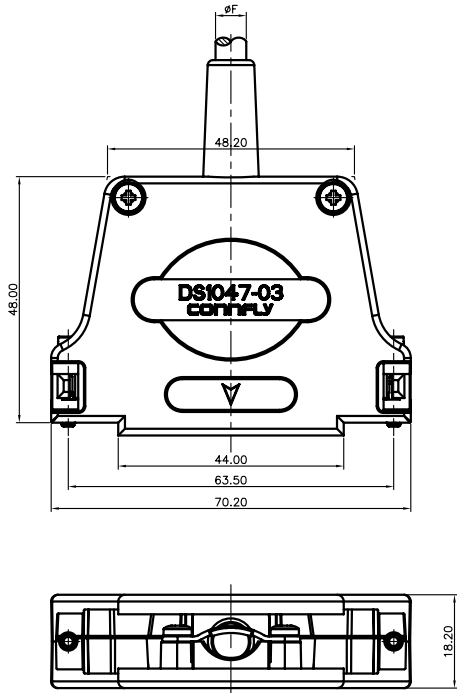

TYPE A

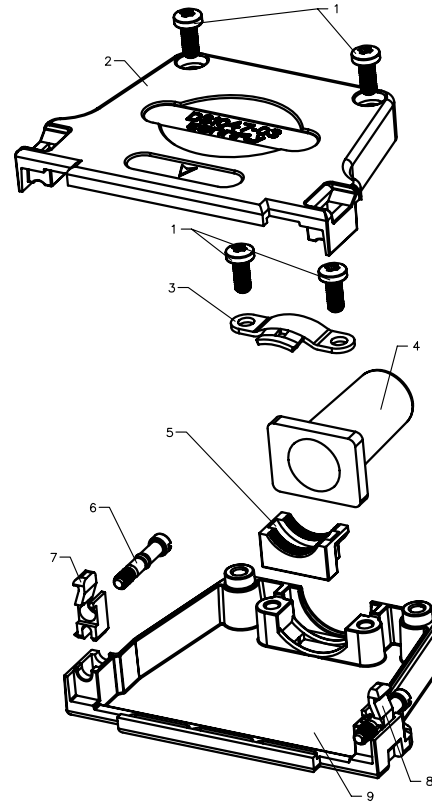

TYPE B

NOTES:
 1. PART NUMBER CODE:
 DS1047-03 - 37 X X X X
 SR Support
 S: W/ SR
 X: W/O SR
 Type Support
 A: Type A
 B: Type B
 Packing type
 1: Mix packing
 2: Separation packing
 Cover Material
 M: Metal(Znic alloy)
 Positions
 37: 37pin

TYPE A BOM LIST			
ITEM	PART NAME	Q'ty	NOTES
1	SCREW	4	M3
2	METAL HOOD-1	1	Znic alloy
3	WASHER	1	
4	CABLE REDUCTION PLATE	2	
5	SR	1	
6	STRAIN RELIEF	1	
7	BOLT	2	UNC 4-40
8	LATCH-1	1	
9	LATCH-2	1	
10	METAL HOOD-2	1	Znic alloy

TYPE B BOM LIST			
ITEM	PART NAME	Q'ty	NOTES
1	SCREW	4	M3
2	METAL HOOD-1	1	Znic alloy
3	WASHER	1	
4	SR	1	
5	STRAIN RELIEF	1	
6	BOLT	2	UNC 4-40
7	LATCH-1	1	
8	LATCH-2	1	
9	METAL HOOD-2	1	Znic alloy

GENERAL TOLERANCE	ANGLE TOLERANCE
X. ±0.60	X. ±5°
.X ±0.38	.X ±3°
.XX ±0.25	.XX ±2°

PROJECTION	TITLE
UNITS	D-SUB 37pin Metal Hoods Straight Cable Outlet Type
SHEET SIZE	SERIES DS1047-03 SERIES

DRAWING TYPE	COSTOMER
SCALE	1:1 SHEET 1 OF 1
DRAWING NO.	C-DS1047-03-37XXXX

晨翔电子有限公司
CONNFLY CONNPLY ELECTRONIC CO. LTD

REV.	DESCRIPTION	DRAWN	CHECKED	APPROVED
A	NEW RELEASE	YCH 12/31/09'	~	

NOTES:
 1. PART NUMBER CODE:
 DS1047-05 - 37 X X

- Packing type
 - 1: Mix packing
 - 2: Separation packing
- Cover Material
 - M: Metal(Znic alloy)
- Positions
 - 37: 37pin

BOM LIST			
ITEM	PART NAME	Q'ty	NOTES
1	METAL HOOD-1	1	
2	METAL HOOD-2	1	
3	LOCATOR	2	
4	SR	1	
5	SCREW	4	
6	WASHER	1	

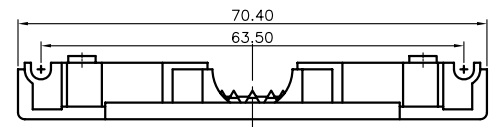
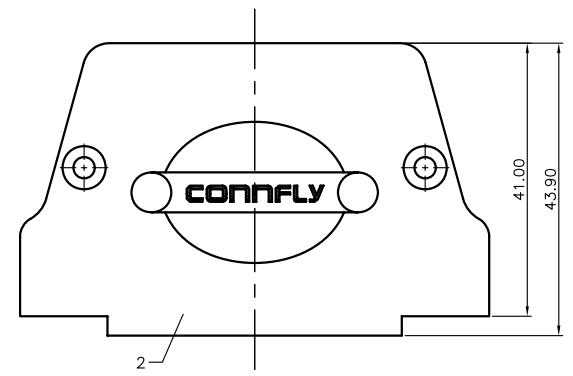
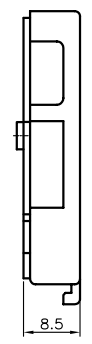
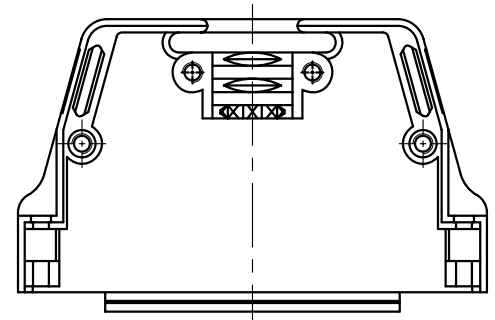
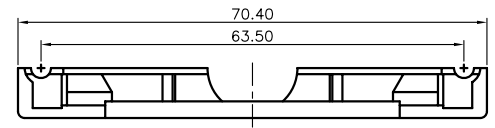
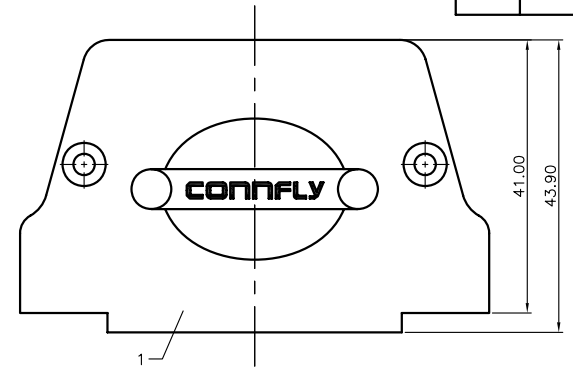
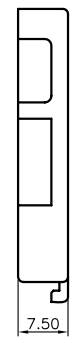
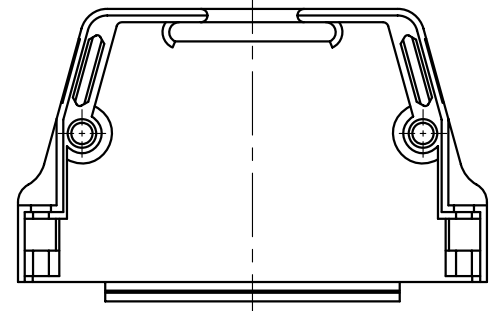
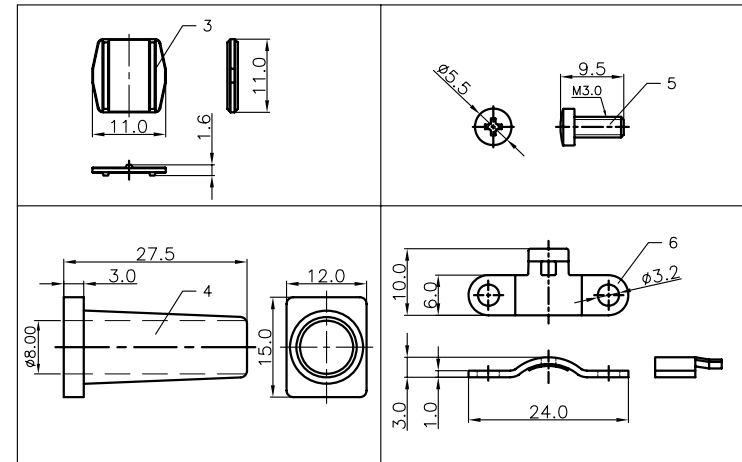

GENERAL TOLERANCE	ANGLE TOLERANCE
X. ±0.60	X. ±5°
.X ±0.38	.X ±3°
.XX ±0.25	.XX ±2°

PROJECTION	TITLE	D-SUB 37pin Metal Hoods Straight Cable Outlet Type	
UNITS	mm		
SHEET SIZE	A4	SERIES	DS1047-05 SERIES

DRAWING TYPE	COSTOMER		
SCALE	1:1	SHEET	1 OF 1
DRAWING NO.	C-DS1047-05-37XX		

晨翔电子有限公司
CONNFLY CONNFLY ELECTRONIC CO. LTD

REV.	DESCRIPTION	DRAWN	CHECKED	APPROVED
A	NEW RELEASE	YCH 12/14/11'	~	

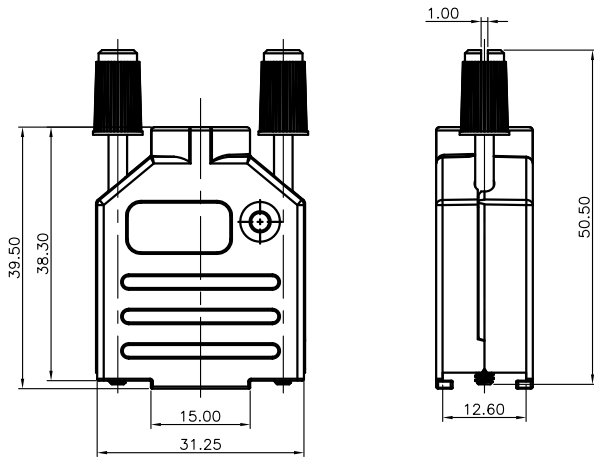

BOM LIST			
ITEM	PART NAME	Q'ty	NOTES
1	UP METAL HOOD	2	Znic alloy
2	SR	2	
3	LONG BOLT	2	UNC 4-40

NOTES:

1. METAL HOOD MATERIAL: Znic alloy

2. PART NUMBER CODE:

DS1049 - 09 X X
 Packing type
 1: Mix packing
 Cover Material
 M: Metal(Znic alloy)
 Positions
 09: 9pin

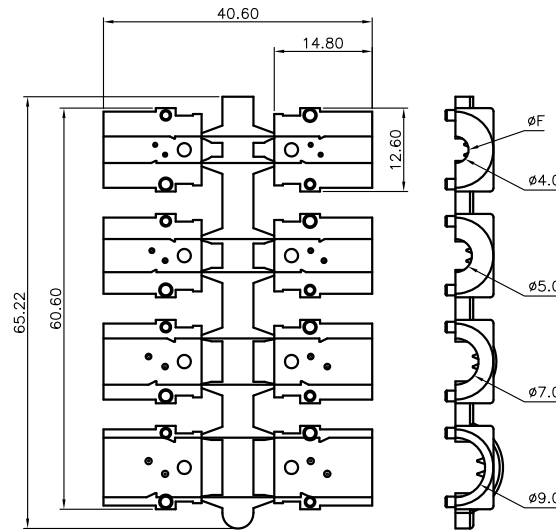
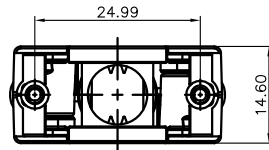

ϕF
$\phi 4.0$
$\phi 5.0$
$\phi 7.0$
$\phi 9.0$

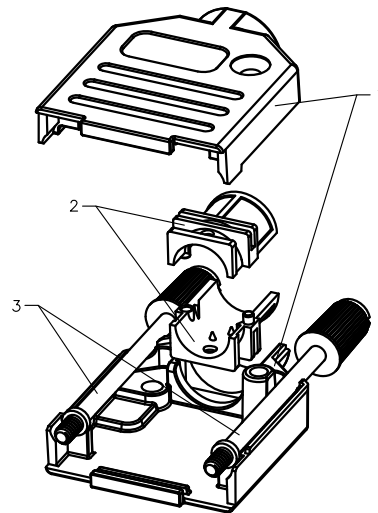
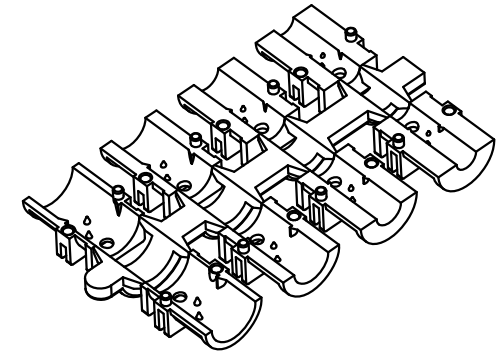

GENERAL TOLERANCE	ANGLE TOLERANCE
X. ± 0.60	X. $\pm 5^\circ$
.X ± 0.38	.X $\pm 3^\circ$
.XX ± 0.25	.XX $\pm 2^\circ$

PROJECTION	TITLE
	D-SUB 9pin Metal Hoods
UNITS	mm
SHEET SIZE	A4
SERIES	DS1049 SERIES

DRAWING TYPE	COSTOMER
SCALE	1:1 SHEET 1 OF 1
DRAWING NO.	C-DS1049-09XX-A

晨翔电子有限公司
CONNFLY CONNFLY ELECTRONIC CO. LTD

REV.	DESCRIPTION	DRAWN	CHECKED	APPROVED
A	NEW RELEASE	YCH 12/14/11'	~	

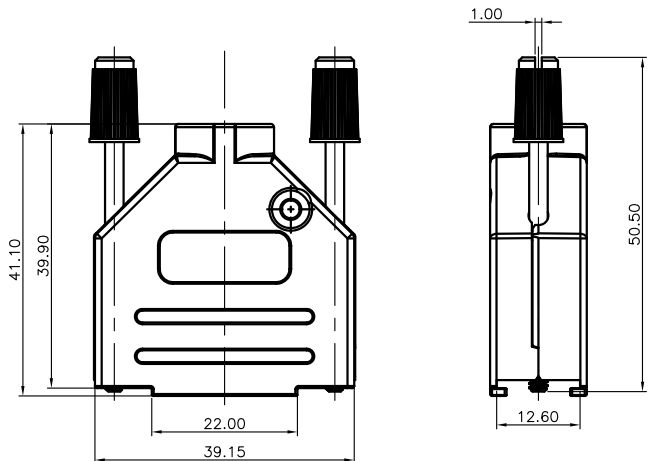

BOM LIST			
ITEM	PART NAME	Q'ty	NOTES
1	UP METAL HOOD	2	Znic alloy
2	SR	2	
3	LONG BOLT	2	UNC 4-40

NOTES:

1. METAL HOOD MATERIAL: Znic alloy

2. PART NUMBER CODE:

DS1049 - 15 X X
 Packing type
 1: Mix packing
 Cover Material
 M: Metal(Znic alloy)
 Positions
 15: 15pin

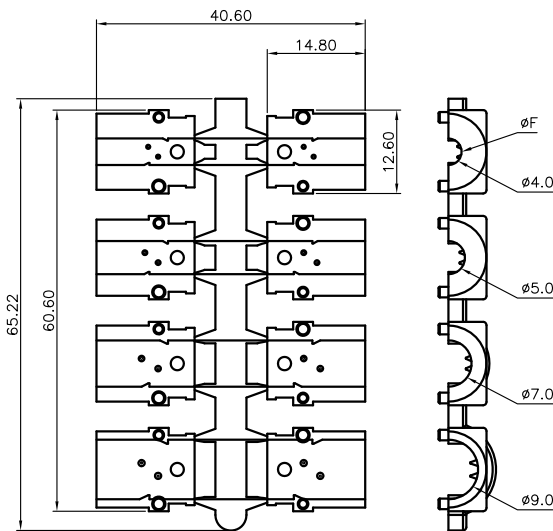
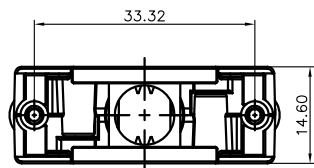

ϕF
$\phi 4.0$
$\phi 5.0$
$\phi 7.0$
$\phi 9.0$

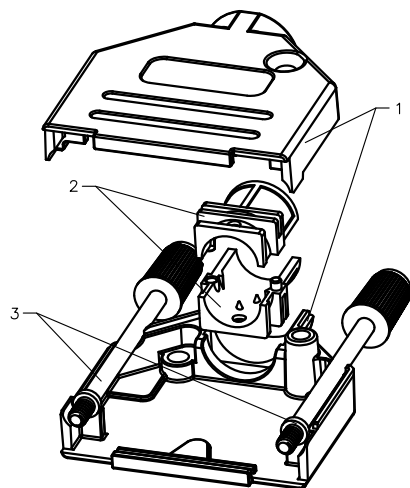
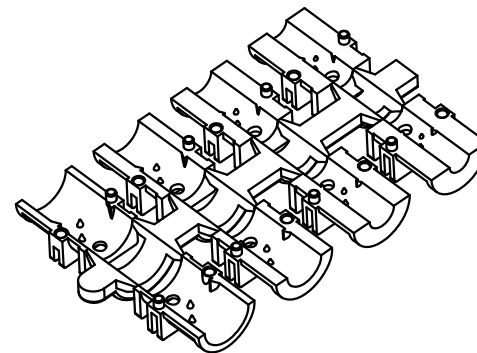

GENERAL TOLERANCE	ANGLE TOLERANCE
X. ± 0.60	X. $\pm 5^\circ$
.X ± 0.38	.X $\pm 3'$
.XX ± 0.25	.XX $\pm 2'$

PROJECTION	TITLE
UNITS	D-SUB 15pin Metal Hoods
SHEET SIZE	SERIES DS1049 SERIES

DRAWING TYPE	COSTOMER
SCALE	1:1 SHEET 1 OF 1
DRAWING NO.	C-DS1049-15XX-A

 晨翔电子有限公司
CONNFLY CONNFLY ELECTRONIC CO. LTD

REV.	DESCRIPTION	DRAWN	CHECKED	APPROVED
A	NEW RELEASE	YCH 12/14/11'	~	

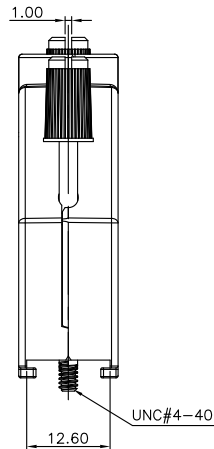
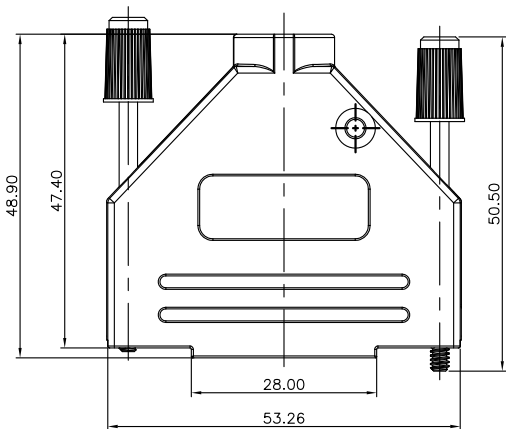

BOM LIST			
ITEM	PART NAME	Q'ty	NOTES
1	UP METAL HOOD	2	Znic alloy
2	SR	2	
3	LONG BOLT	2	UNC 4-40

NOTES:

1. METAL HOOD MATERIAL: Znic alloy

2. PART NUMBER CODE:

DS1049 - 25 X X

Packing type
1: Mix packing

Cover Material
M: Metal(Znic alloy)

Positions
25: 25pin

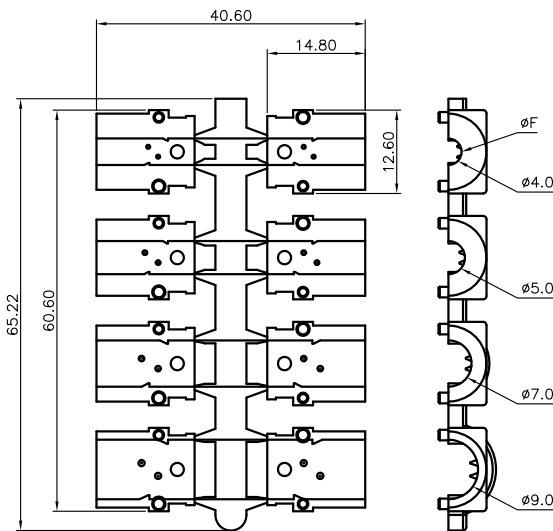
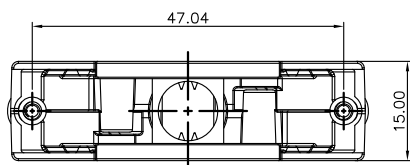

ϕF
$\phi 4.0$
$\phi 5.0$
$\phi 7.0$
$\phi 9.0$

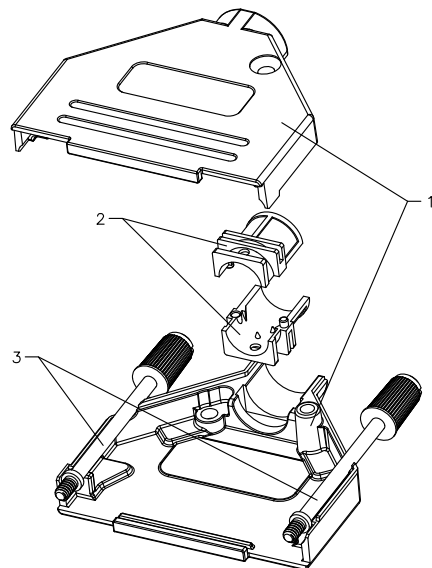
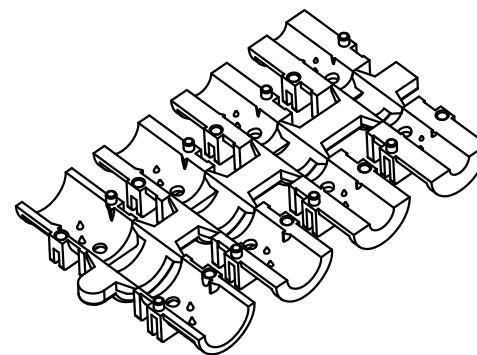

GENERAL TOLERANCE	ANGLE TOLERANCE
X. ± 0.60	X. $\pm 5^\circ$
.X ± 0.38	.X $\pm 3^\circ$
.XX ± 0.25	.XX $\pm 2^\circ$

PROJECTION	TITLE
UNITS: mm	D-SUB 25pin Metal Hoods
SHEET SIZE: A4	SERIES: DS1049 SERIES

DRAWING TYPE	COSTOMER
SCALE: 1:1	SHEET: 1 OF 1
DRAWING NO.: C-DS1049-25XX-A	

 晨翔电子有限公司
CONNFLY CONNFLY ELECTRONIC CO. LTD