

BOM LIST			
ITEM	PART NAME	Q'ty	NOTES
1	PLASTIC HOOD	2	ABS
2	2.1 LONG BOLT	2	#4-40
	2.2 SHORT BOLT	2	#4-40
3	NUT	2	M3
4	LONG SCREW	2	M3
5	SMALL WASHER	2	
6	SHORT SCREW	2	M3
7	7.1 METAL WASHER	2	M3
	7.2 PLASTIC-1 WASHER	2	ABS
	7.3 PLASTIC-2 WASHER	2	ABS

REV.	DESCRIPTION	DRAWN	CHECKED	APPROVED
A	NEW RELEASE	LJH 08/13/05'	~	LJC 08/13/05'
B	整理图画	YCH 09/13/07'	~	LJC 09/13/07'
C	整理英制短螺丝尺寸	YCH 07/18/08'	~	LJC 07/18/08'
D	增加“全包装”类型	YCH 05/20/10'	~	LJC 05/20/10'
E	改M3*12的螺钉为M3*10	YCH 08/30/10'	~	

NOTES:

1. Hardwares are all Nickel plated.

2. PART NUMBER CODE:
DS1045 - 09 X X X X X

Washer type
1: Metal
2: Plastic-1(Lock type)
3: Plastic-2(Screw type)

Bolt type
L: Long
S: Short

Packing type
1: Mix packing
2: Separation packing
Q: Full packing

Cover Material
P: Plastic(ABS)

Cover Color
A: Gray
B: Black
V: Ivory

Position
09: 9pin

GENERAL TOLERANCE	ANGLE TOLERANCE
X. ±0.60	X. ±5°
.X ±0.38	.X ±3°
.XX ±0.25	.XX ±2°

PROJECTION	TITLE
UNITS: mm	D-SUB 9pin Hood
SHEET SIZE: A4	SERIES: DS1045 SERIES

DRAWING TYPE	CUSTOMER
SCALE: 1:1	SHEET: 1 OF 1
DRAWING NO.:	C-DS1045-09XXXXX-E

晨翔电子有限公司
CONNFLY CONNFLY ELECTRONIC CO. LTD

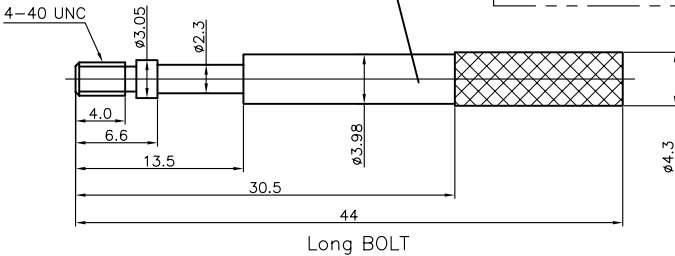
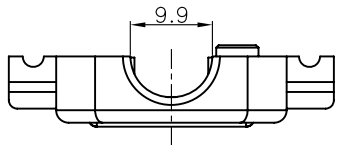
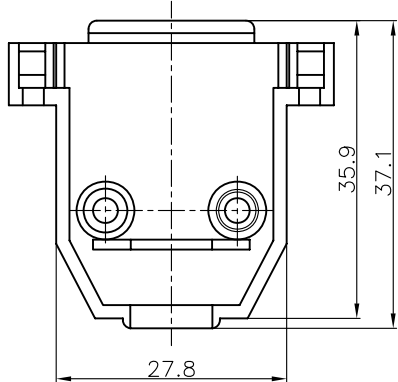
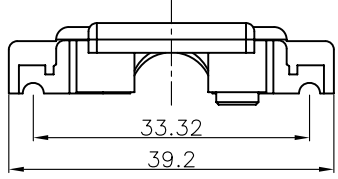

BOM LIST			
ITEM	PART NAME	Q'ty	NOTES
1	PLASTIC HOOD	2	ABS
2	2.1 LONG BOLT	2	#4-40
	2.2 SHORT BOLT	2	#4-40
3	NUT	2	M3
4	LONG SCREW	2	M3
5	SMALL WASHER	2	
6	SHORT SCREW	2	M3
7	7.1 METAL WASHER	2	M3
	7.2 PLASTIC-1 WASHER	2	ABS
	7.3 PLASTIC-2 WASHER	2	ABS

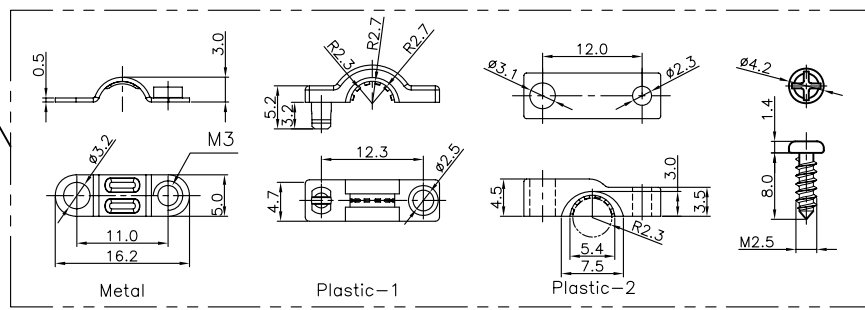
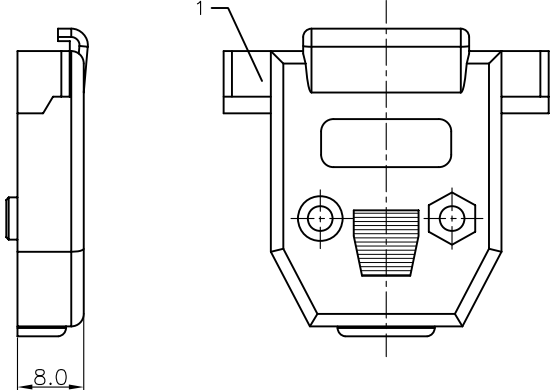

REV.	DESCRIPTION	DRAWN	CHECKED	APPROVED
A	NEW RELEASE	LJH 05/18/05'	~	LJC 05/18/05'
B	整理图画	YCH 09/13/07'	~	LJC 09/13/07'
C	整理英制短螺丝尺寸	YCH 07/18/08'	~	LJC 07/18/08'
D	增加“全包装”类型	YCH 05/20/10'	~	

NOTES:
 1. Hardwares are all Nickel plated.
 2. PART NUMBER CODE:

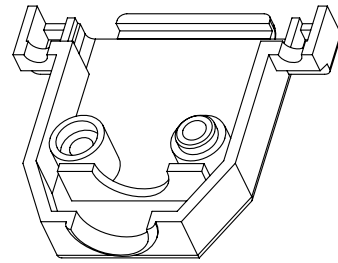

DS1045 - 15 X X X X X
 Washer type
 1: Metal
 2: Plastic-1(Lock type)
 3: Plastic-2(Screw type)
 Bolt type
 L: Long
 S: Short
 Packing type
 1: Mix packing
 2: Separation packing
 Q: Full packing
 Cover Material
 P: Plastic(ABS)
 Cover Color
 A: Gray
 B: Black
 V: Ivory
 Position
 15: 15pin

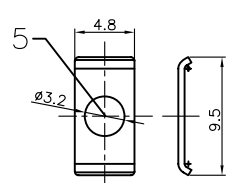
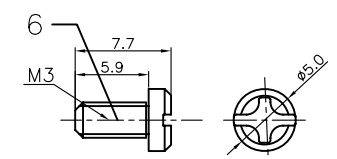
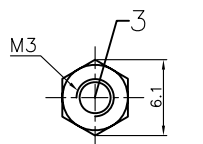
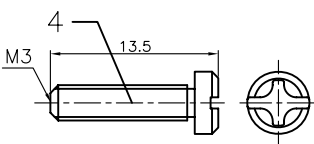
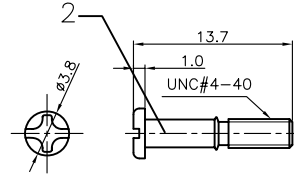

GENERAL TOLERANCE	ANGLE TOLERANCE
X. ±0.60	X. ±5°
.X ±0.38	.X ±3°
.XX ±0.25	.XX ±2°

PROJECTION	TITLE
UNITS: mm	D-SUB 15pin Hood
SHEET SIZE: A4	SERIES: DS1045 SERIES

DRAWING TYPE	COSTOMER
SCALE: 1:1	SHEET: 1 OF 1
DRAWING NO.:	C-DS1045-15XXXXX-D

晨翔电子有限公司
CONNFLY CONNFLY ELECTRONIC CO. LTD

BOM LIST			
ITEM	PART NAME	Q'ty	NOTES
1	PLASTIC HOOD	2	ABS
2	2.1 LONG BOLT	2	#4-40
	2.2 SHORT BOLT	2	#4-40
3	NUT	2	M3
4	LONG SCREW	2	M3
5	SMALL WASHER	2	
6	SHORT SCREW	2	M3
7	7.1 METAL WASHER	2	M3
	7.2 PLASTIC-1 WASHER	2	ABS
	7.3 PLASTIC-2 WASHER	2	ABS

REV.	DESCRIPTION	DRAWN	CHECKED	APPROVED
A	NEW RELEASE	LJH 10/26/05'	~	LJC 10/26/05'
B	整理图画	YCH 09/13/07'	~	LJC 09/13/07'
C	整理英制短螺丝尺寸	YCH 07/18/08'	~	LJC 07/18/08'
D	增加“全包装”类型	YCH 05/20/10'	~	

NOTES:

1. Hardware are all Nickel plated.
2. PART NUMBER CODE:

DS1045 - 25 X X X X X

- Washer type
- 1: Metal
- 2: Plastic-1(Lock type)
- 3: Plastic-2(Screw type)

- Bolt type
- L: Long
- S: Short
- Packing type
- 1: Mix packing
- 2: Separation packing
- Q: Full packing

- Cover Material
- P: Plastic(ABS)
- Cover Color
- A: Gray
- B: Black
- V: Ivory
- Position
- 25: 25pin

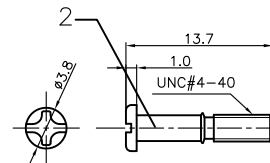

Short BOLT

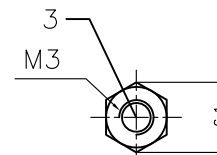

NUT t=2.3mm

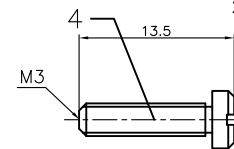

LONG SCREW

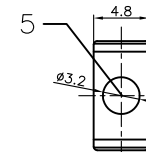

SMALL WASHER

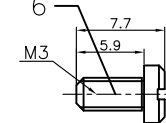

SHORT SCREW

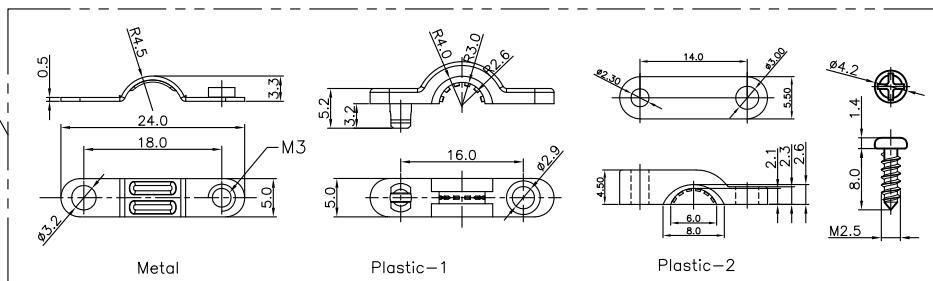

Metal

Plastic-1

Plastic-2

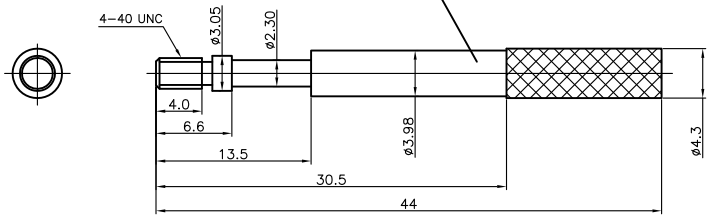
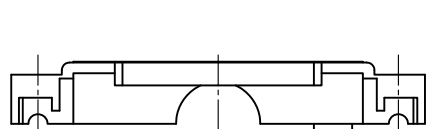
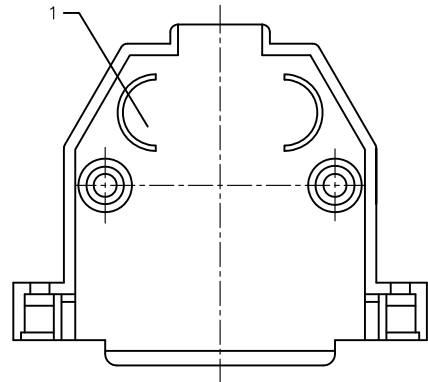
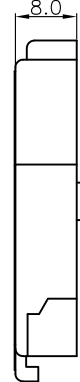
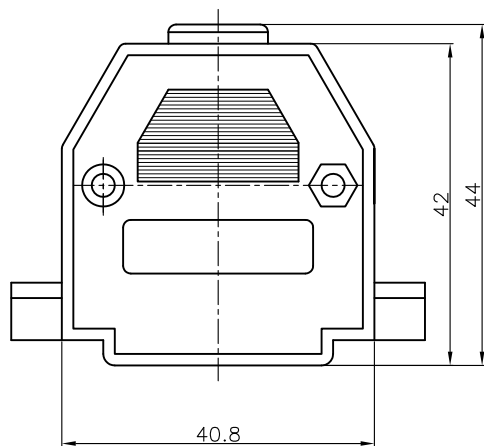
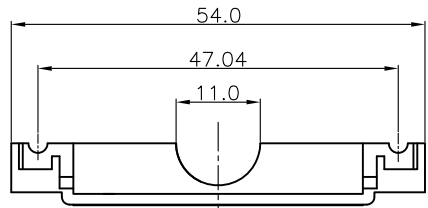

Long BOLT

GENERAL TOLERANCE	ANGLE TOLERANCE
X. ±0.60	X. ±5°
.X ±0.38	.X ±3°
.XX ±0.25	.XX ±2°

PROJECTION	TITLE
UNITS mm	D-SUB 25pin Hood
SHEET SIZE A4	SERIES DS1045 SERIES

DRAWING TYPE	COSTOMER
SCALE 1:1	SHEET 1 OF 1
DRAWING NO. C-DS1045-25XXXXX-D	

晨翔电子有限公司
CONNFLY CONNFLY ELECTRONIC CO. LTD

BOM LIST			
ITEM	PART NAME	Q'ty	NOTES
1	PLASTIC HOOD	2	ABS
2	LONG BOLT	2	#4-40
	SHORT BOLT	2	#4-40
3	NUT	2	M3
4	LONG SCREW	2	M3
5	SMALL WASHER	2	
6	SHORT SCREW	2	M3
7	METAL WASHER	2	M3
	PLASTIC-1 WASHER	2	ABS
	PLASTIC-2 WASHER	2	ABS

REV.	DESCRIPTION	DRAWN	CHECKED	APPROVED
A	NEW RELEASE	LJH 10/26/05'	~	LJC 10/26/05'
B	整理图面	YCH 09/13/07'	~	LJC 09/13/07'
C	整理英制短螺丝尺寸	YCH 07/18/08'	~	LJC 07/18/08'
D	增加“全包装”类型	YCH 05/20/10'	~	

NOTES:

1. Hardware are all Nickel plated.
2. PART NUMBER CODE:

DS1045 - 37 X X X X X

- Washer type
- 1: Metal
- 2: Plastic-1(Lock type)
- 3: Plastic-2(Screw type)
- Bolt type
- L: Long
- S: Short
- Packing type
- 1: Mix packing
- 2: Separation packing
- Q: Full packing
- Cover Material
- P: Plastic(ABS)
- Cover Color
- A: Gray
- B: Black
- V: Ivory
- Position
- 37: 37pin

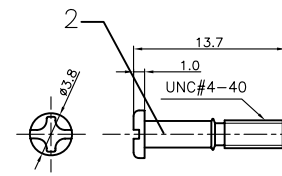
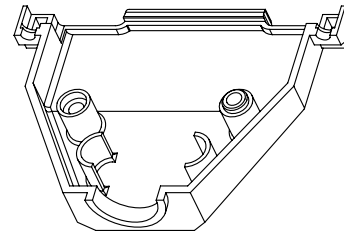

Short BOLT

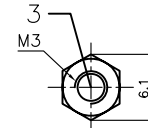

NUT t=2.3mm

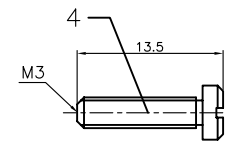

LONG SCREW

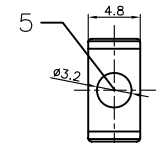

SMALL WASHER

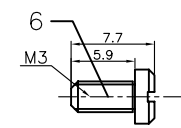

SHORT SCREW

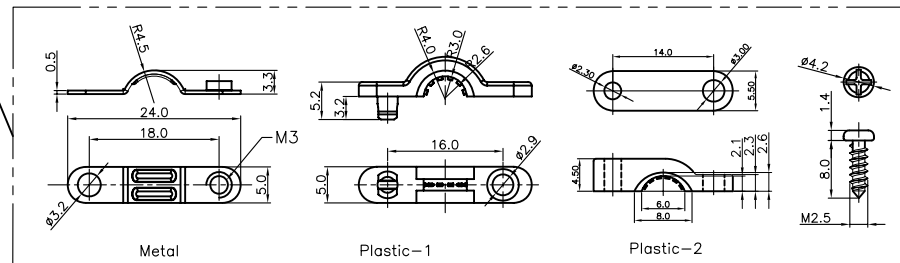

Metal

Plastic-1

Plastic-2

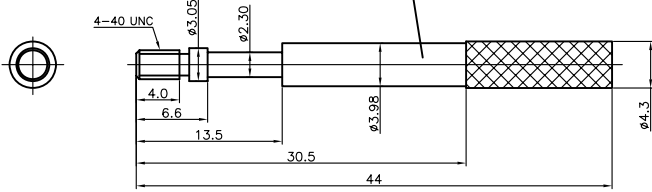
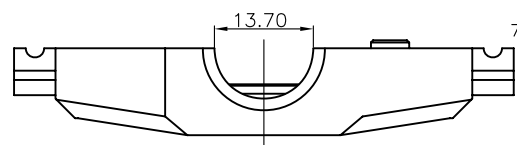
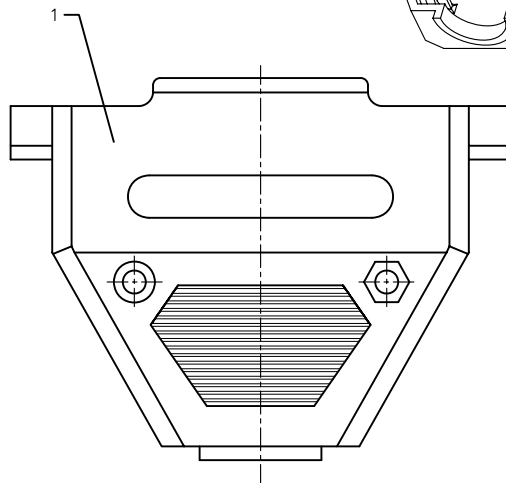
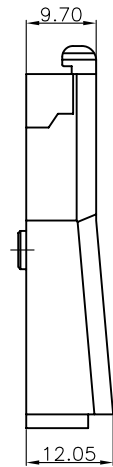
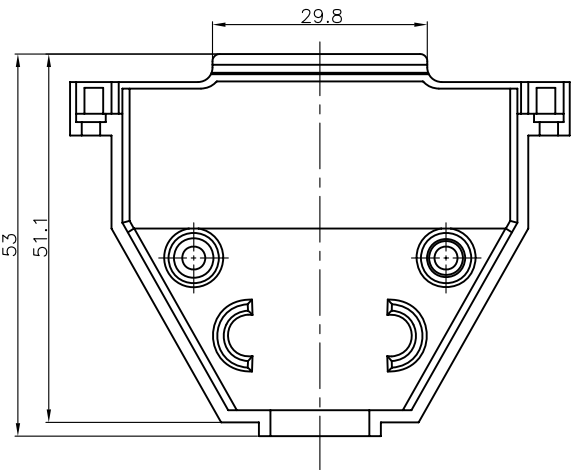
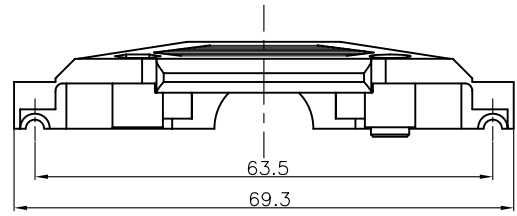

Long BOLT

GENERAL TOLERANCE	ANGLE TOLERANCE
X. ±0.60	X. ±5°
.X ±0.38	.X ±3°
.XX ±0.25	.XX ±2°

PROJECTION	TITLE
	D-SUB 37pin Hood
UNITS	mm
SHEET SIZE	A4
SERIES	DS1045 SERIES

DRAWING TYPE	COSTOMER
SCALE	1:1 SHEET 1 OF 1
DRAWING NO.	C-DS1045-37XXXXX-D

晨翔电子有限公司
CONNFLY CONNFLY ELECTRONIC CO. LTD

REV.	DESCRIPTION	DRAWN	CHECKED	APPROVED
A	NEW RELEASE	YCH 05/24/11'	~	

NOTES:

1. PART NUMBER CODE:

DS1045 - 50 X X X

- Packing type
- 1: Mix packing
- 2: Separation packing
- Cover Color
- A: Gray
- B: Black
- Cover Material
- P: Plastic(ABS)
- Position
- 50: 50pin

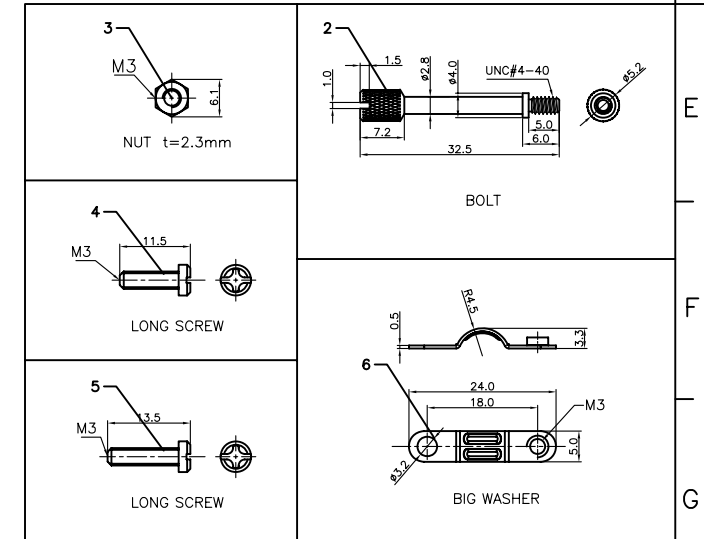
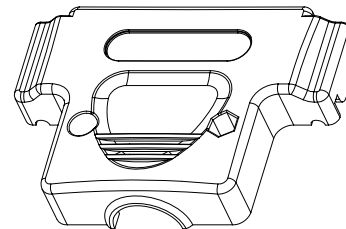
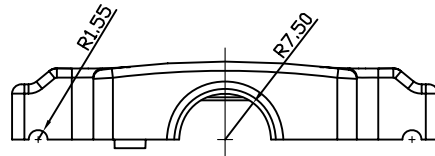
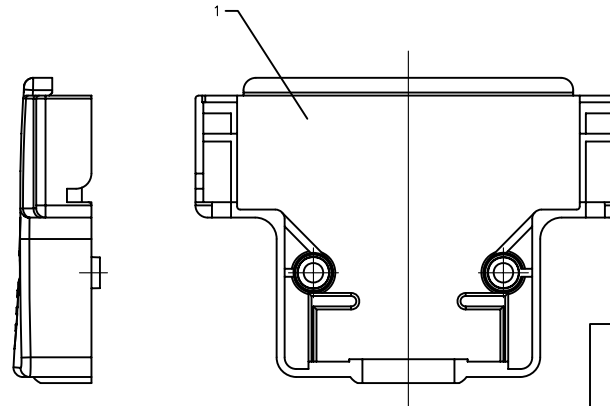
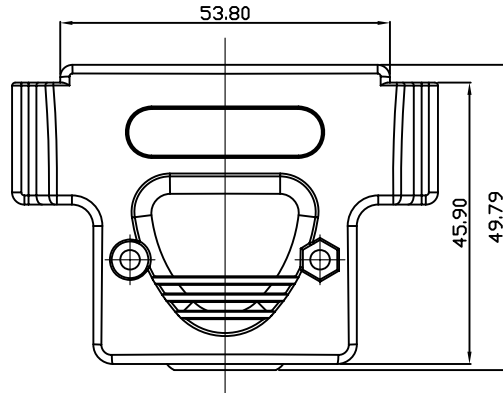
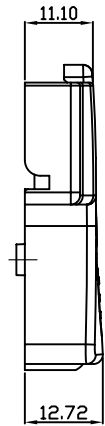
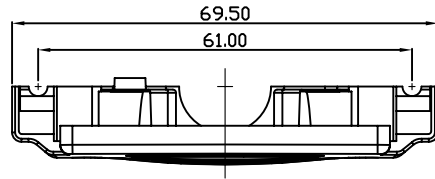

BOM LIST			
ITEM	PART NAME	Q'ty	NOTES
1	PLASTIC HOOD	2	ABS
2	BOLT	2	#4-40
3	NUT	2	M3
4	M3*10 SCREW	2	M3
5	M3*12 SCREW	2	M3
6	BIG WASHER	2	M3

GENERAL TOLERANCE		ANGLE TOLERANCE	
X.	±0.60	X.	±5°
.X	±0.38	.X	±3°
.XX	±0.25	.XX	±2°

PROJECTION	TITLE	D-SUB 50pin HOOD	
UNITS	mm	SHEET	1 OF 1
SHEET SIZE	A4	SERIES	DS1045 SERIES

DRAWING TYPE	CUSTOMER		
SCALE	1:1	SHEET	1 OF 1
DRAWING NO.	C-DS1045-50XXX		

晨翔电子有限公司
CONNFLY CONNFLY ELECTRONIC CO. LTD

REV.	DESCRIPTION	DRAWN	CHECKED	APPROVED
A	NEW RELEASE	LJH 12/20/05'	~	LJC 12/20/05'
B	整理图面	YCH 09/14/07'	~	

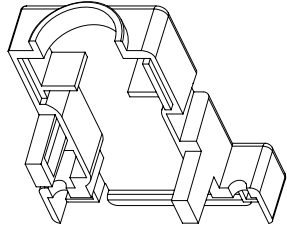

NOTES:

1. PART NUMBER CODE:

DS1048 - 09 X X X X

- Bolt type
L: Long
S: Short
- Packing type
1: Mix packing
2: Separation packing
- Cover Material
P: Plastic(ABS)
- Cover Color
A: Gray
B: Black
V: Ivory
- Position
09: 9pin

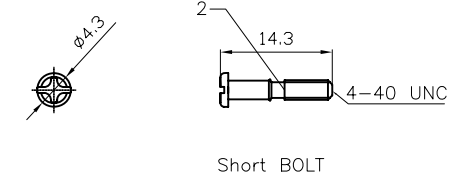
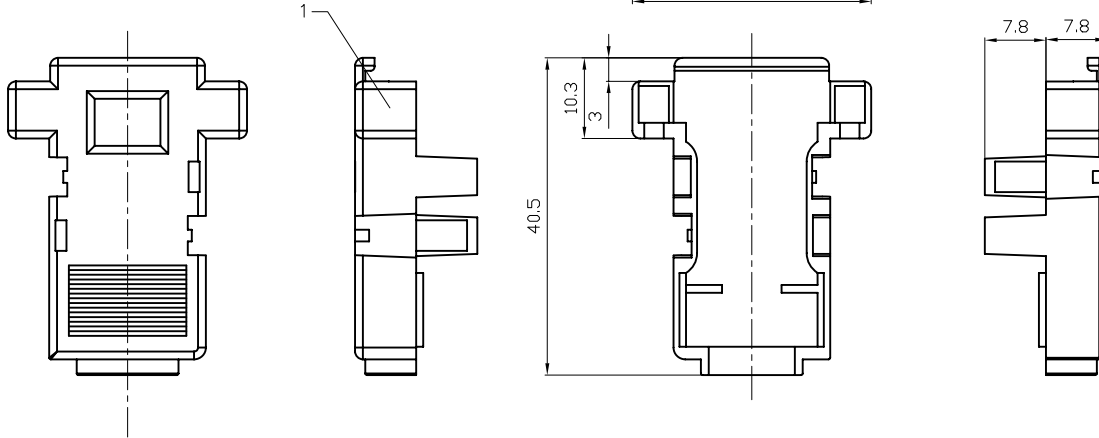

Short BOLT

BOM LIST			
ITEM	PART NAME	Q'ty	NOTES
1	PLASTIC HOOD	2	ABS
2	BOLT	2	#4-40

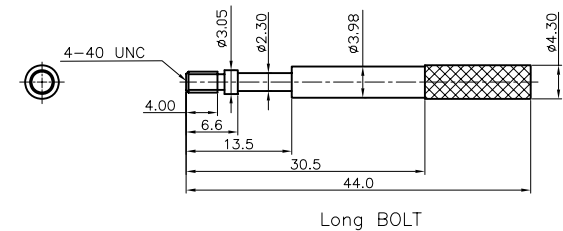
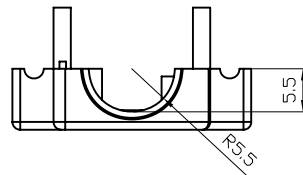

Long BOLT

GENERAL TOLERANCE		ANGLE TOLERANCE		PROJECTION	TITLE
X.	±0.60	X.	±5°		PLASTIC FROM THE LOCK TYPE
.X	±0.38	.X	±3°	UNITS	mm
.XX	±0.25	.XX	±2°	SHEET SIZE	A4
DRAWING TYPE		COSTOMER		SERIES	DS1048 SERIES
SCALE		1:1	SHEET	1 OF 1	
DRAWING NO.		C-DS1048-09XXXX			

晨翔电子有限公司
CONNFLY CONNFLY ELECTRONIC CO. LTD

REV.	DESCRIPTION	DRAWN	CHECKED	APPROVED
A	NEW RELEASE	LJH 12/20/05'	~	LJC 12/20/05'
B	整理图面	YCH 09/14/07'	~	

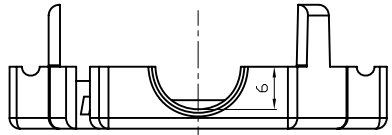
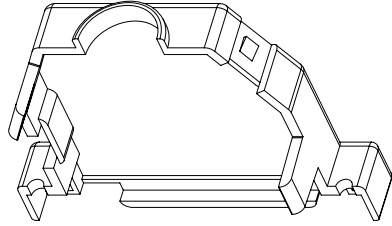

BOM LIST			
ITEM	PART NAME	Q'ty	NOTES
1	PLASTIC HOOD	2	ABS
2	BOLT	2	#4-40

NOTES:

1. PART NUMBER CODE:

DS1048 - 25 X X X X

Bolt type
L: Long
S: Short

Packing type
1: Mix packing
2: Separation packing

Cover Material
P: Plastic(ABS)

Cover Color
A: Gray
B: Black
V: Ivory

Position
25: 25pin

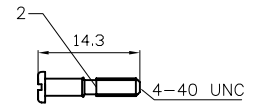
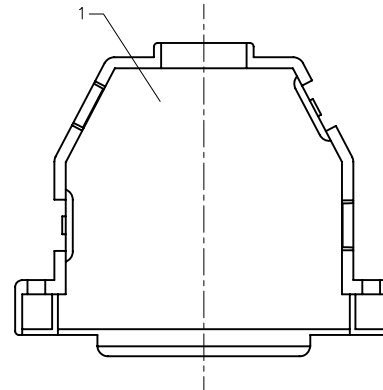
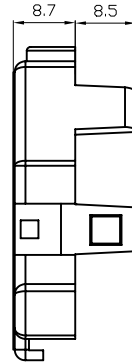
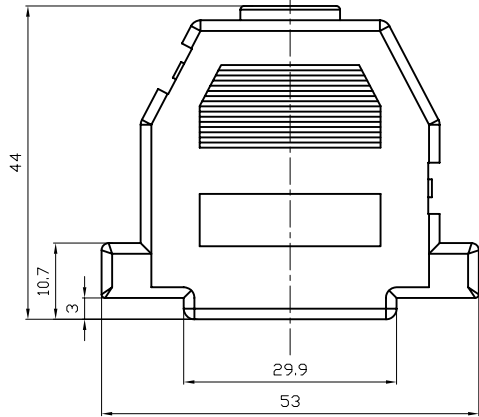
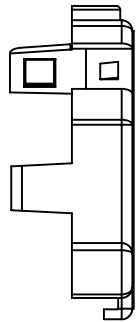

Short BOLT

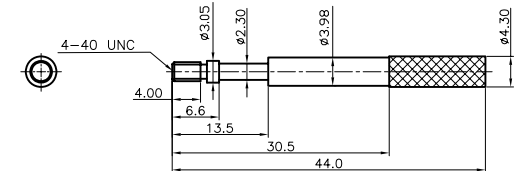

Long BOLT

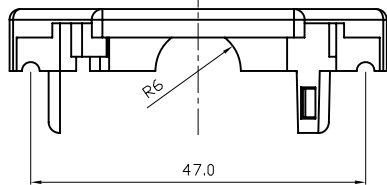

GENERAL TOLERANCE		ANGLE TOLERANCE		PROJECTION		TITLE	PLASTIC FROM THE LOCK TYPE	
X.	±0.60	X.	±5°	UNITS	mm	SHEET SIZE	A4	
.X	±0.38	.X	±3°	SHEET SIZE	A4	SERIES	DS1048 SERIES	
.XX	±0.25	.XX	±2°	晨翔电子有限公司 CONNFLY CONNFLY ELECTRONIC CO. LTD				
DRAWING TYPE		COSTOMER						
SCALE	1:1	SHEET	1 OF 1					
DRAWING NO.		C-DS1048-25XXXX						

REV.	DESCRIPTION	DRAWN	CHECKED	APPROVED
A	NEW RELEASE	YCH 02/23/08'	~	

NOTES:

- HOODS MATERIAL:ABS
- PART NUMBER CODE:

DS1055- X X X X X X

Bolt type
L: Long
Contact plating
0: (D-SUB Selective gold flash
RJ45 Full gold flash)

Cover color
V: Ivory
B: Black
A: Gray
Position
8: 8p8c
4: 4p4c

Connector type
M: Male
F: Female

No. of contact
09: 9pos.
15: 15pos.
25: 25pos.
37: 37pos.

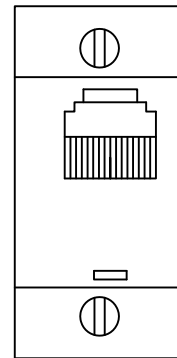
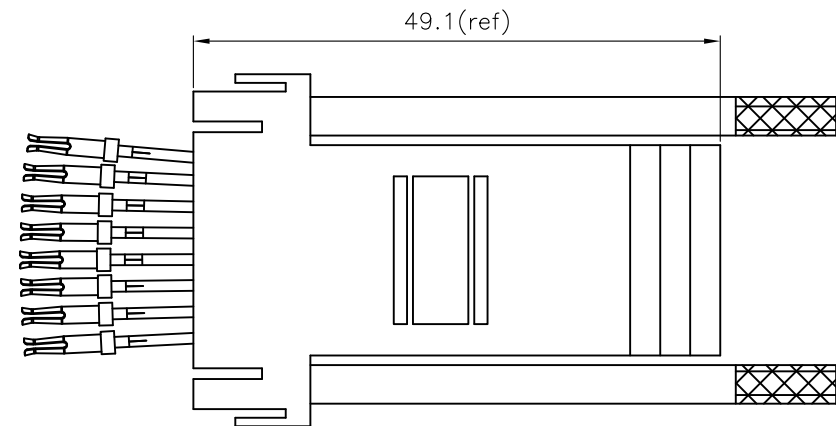
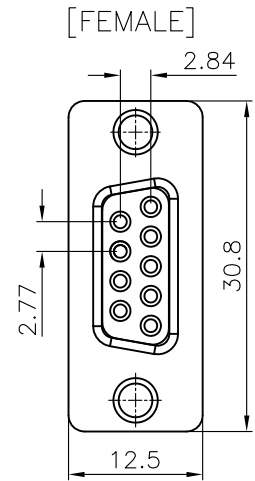
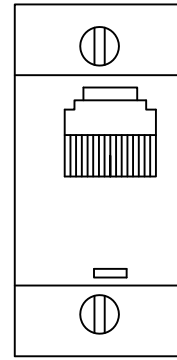
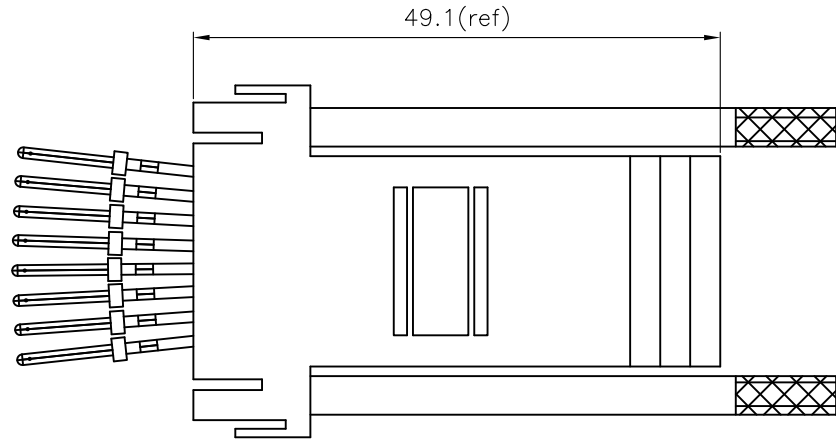
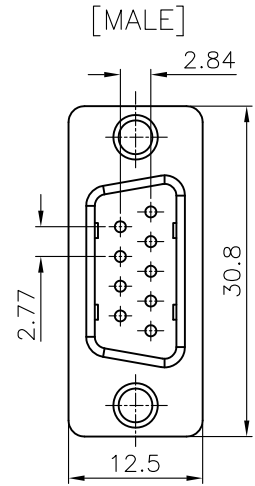

GENERAL TOLERANCE		ANGLE TOLERANCE	
X.	±0.60	X.	±5°
.X	±0.38	.X	±3°
.XX	±0.25	.XX	±2°

PROJECTION		TITLE	D-SUB CRIMP TYPE AND PCB JACK	
UNITS	mm	SHEET SIZE	A4	
SHEET SIZE	A4	SERIES	DS1055 SERIES	

DRAWING TYPE	CUSTOMER		
SCALE	1:1	SHEET	1 OF 1
DRAWING NO.	C-DS1055-XXXXXXX		

晨翔电子有限公司
CONNFLY CONNFLY ELECTRONIC CO. LTD

REV.	DESCRIPTION	DRAWN	CHECKED	APPROVED
A	NEW RELEASE	YCH 08/30/07'	~	

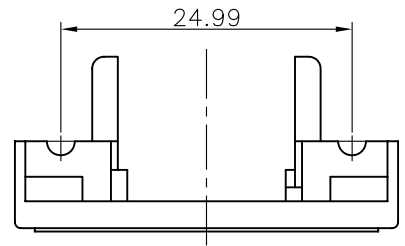

BOM LIST			
ITEM	PART NAME	Q'ty	NOTES
1	PLASTIC HOOD	2	ABS
2	BOLT	4	#4-40

NOTES:
 1. HOODS MATERIAL: ABS
 2. PART NUMBER CODE:
 DS1061 - 09 X X X

- Packing type
 1: Mix packing
 2: Separation packing
- Cover Color
 A: Gray
 B: Black
 V: Ivory
- Cover Material
 P: Plastic(ABS)
- Position
 09: 9pin

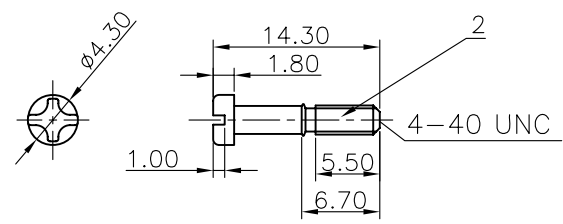
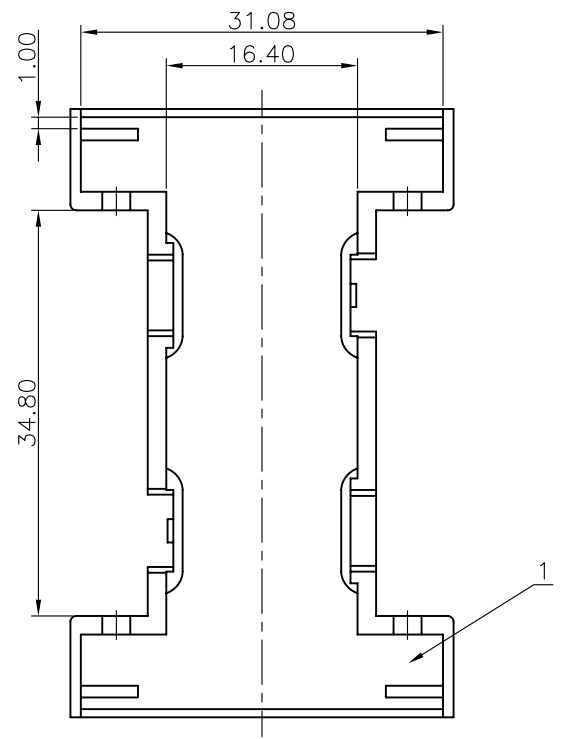
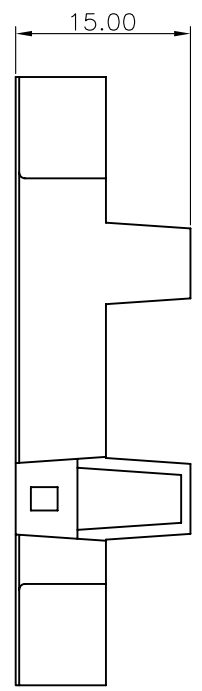
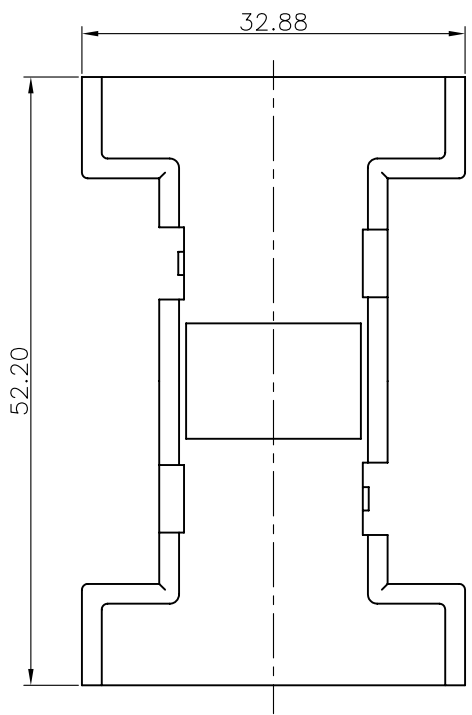

GENERAL TOLERANCE		ANGLE TOLERANCE		PROJECTION		TITLE	
X. ±0.60	.X ±0.38	.X ±5°	.X ±3°	UNITS	mm	D-SUB 9pin Cover	
.XX ±0.25		.XX ±2°		SHEET SIZE	A4	SERIES	DS1061 SERIES
DRAWING TYPE		COSTOMER		晨翔电子有限公司 CONNFLY CONNFLY ELECTRONIC CO. LTD			
SCALE		1:1					
DRAWING NO.		C-DS1061-09XXX					

REV.	DESCRIPTION	DRAWN	CHECKED	APPROVED
A	NEW RELEASE	YCH 08/30/07'	~	

BOM LIST			
ITEM	PART NAME	Q'ty	NOTES
1	PLASTIC HOOD	2	ABS
2	BOLT	4	#4-40

1. HOODS MATERIAL: ABS
 2. PART NUMBER CODE:

DS1061 - 25 X X X

Packing type
 1: Mix packing
 2: Separation packing
 Cover Color
 A: Gray
 B: Black
 V: Ivory
 Cover Material
 P: Plastic(ABS)
 Position
 25: 25pin

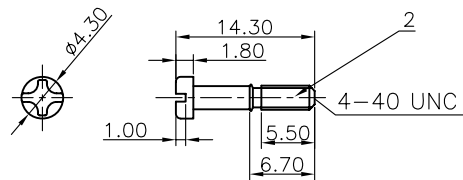
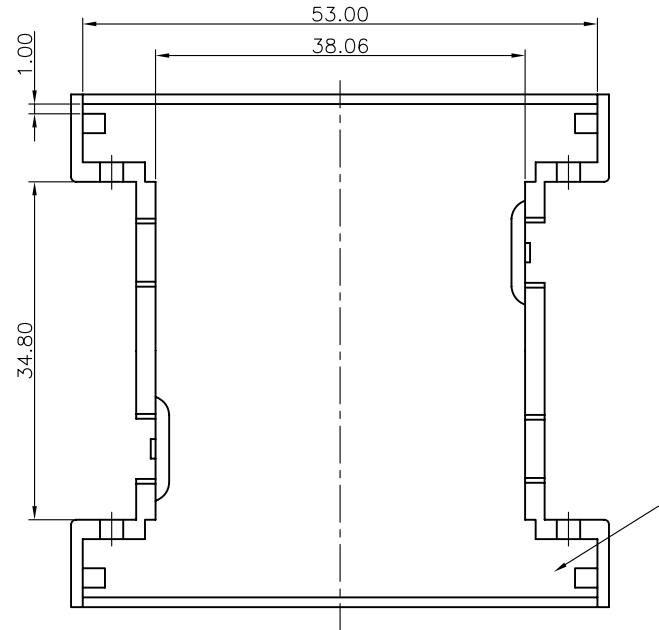
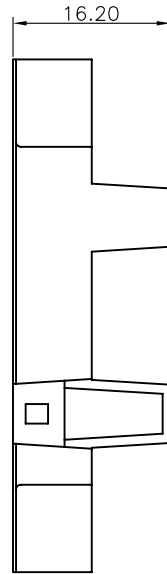
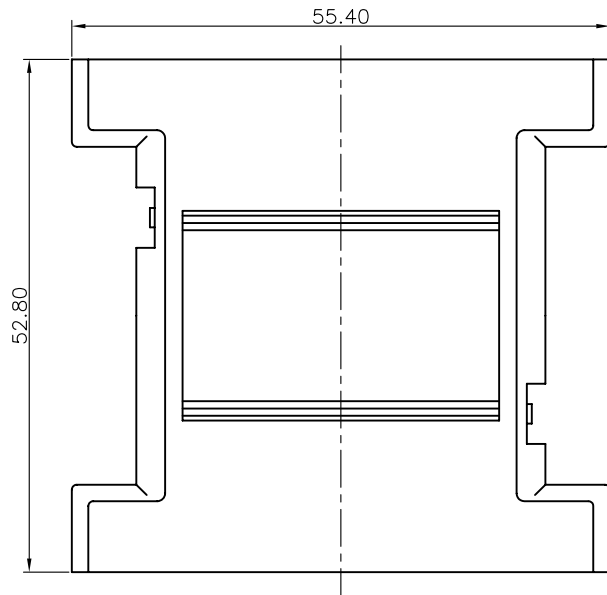
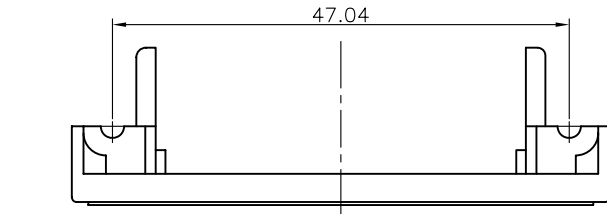

GENERAL TOLERANCE		ANGLE TOLERANCE		PROJECTION		TITLE	D-SUB 25pin Cover		
X.	±0.60	X.	±5°	UNITS	mm	SERIES	DS1061 SERIES		
.X	±0.38	.X	±3°	SHEET SIZE	A4				
.XX	±0.25	.XX	±2°						
DRAWING TYPE		COSTOMER			晨翔电子有限公司 CONNFLY CONNFLY ELECTRONIC CO. LTD				
SCALE		1:1	SHEET 1 OF 1						
DRAWING NO.		C-DS1061-25XXX							

REV.	DESCRIPTION	DRAWN	CHECKED	APPROVED
A	NEW RELEASE	YCH 12/16/09'	~	

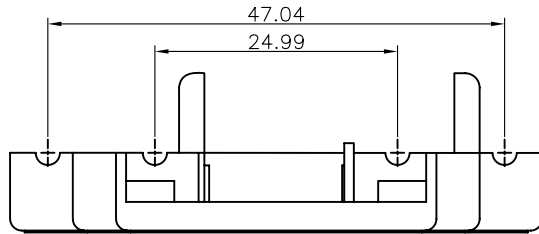

BOM LIST			
ITEM	PART NAME	Q'ty	NOTES
1	PLASTIC HOOD	2	ABS
2	BOLT	4	#4-40

1. HOODS MATERIAL: ABS
 2. PART NUMBER CODE:
 DS1061-01 - 925 X X X

Packing type
 1: Mix packing
 2: Separation packing
 Cover Color
 A: Gray
 B: Black
 V: Ivory
 Cover Material
 P: Plastic(ABS)
 Position
 925: 9 to 25pin

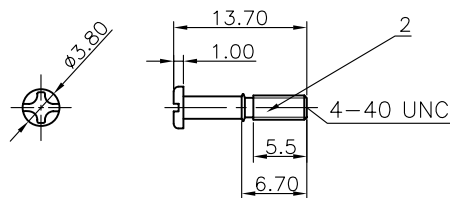
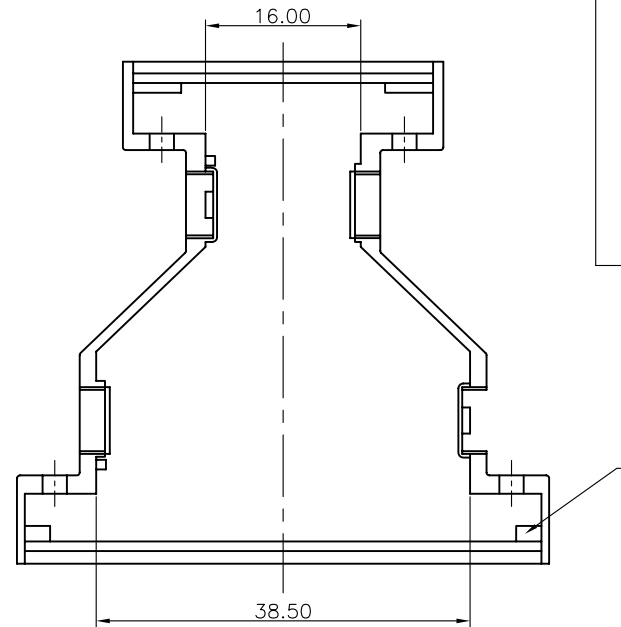
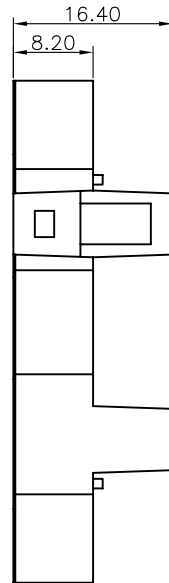
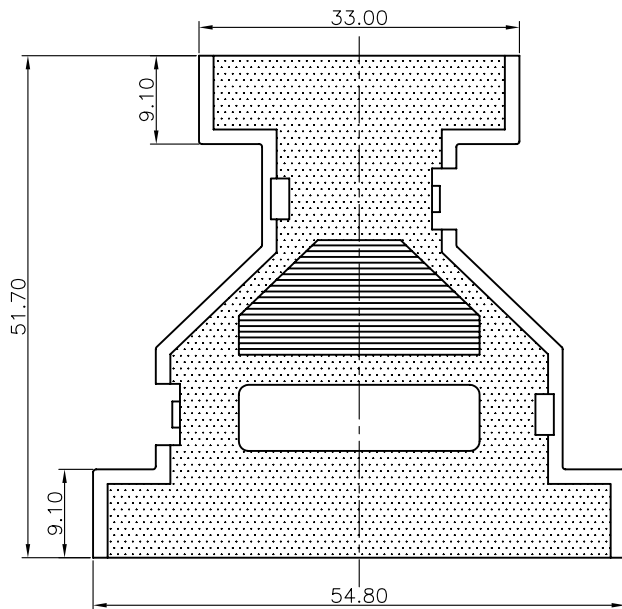

GENERAL TOLERANCE		ANGLE TOLERANCE		PROJECTION	TITLE	D-SUB 9 TO 25 PLASTIC HOODS	
X. ±0.60	.X ±0.38	.X ±5°	.X ±3°	mm		SHEET SIZE	DS1061-01 SERIES
.XX ±0.25		.XX ±2°		A4			
DRAWING TYPE		CUSTOMER		 晨翔电子有限公司 CONNFLY CONNFLY ELECTRONIC CO. LTD			
SCALE	1:1	SHEET	1 OF 1				
DRAWING NO.	C-DS1061-01-925XXX						