

BOM LIST			
ITEM	PART NAME	Q'ty	NOTES
1	PLASTIC HOOD	2	ABS
2	2.1 LONG BOLT	2	#4-40
	2.2 SHORT BOLT	2	#4-40
3	NUT	2	M3
4	LONG SCREW	2	M3
5	SMALL WASHER	2	
6	SHORT SCREW	2	M3
7	7.1 METAL WASHER	2	M3
	7.2 PLASTIC-1 WASHER	2	ABS
	7.3 PLASTIC-2 WASHER	2	ABS

REV.	DESCRIPTION	DRAWN	CHECKED	APPROVED
A	NEW RELEASE	LJH 08/13/05'	~	LJC 08/13/05'
B	整理图画	YCH 09/13/07'	~	LJC 05/20/10'
C	改M3*12的螺钉为M3*10	YCH 08/30/10'	~	

NOTES:

1. PART NUMBER CODE:

DS1046 - 09 X X X X

- Washer type
- 1: Metal
- 2: Plastic-1(Lock type)
- 3: Plastic-2(Screw type)
- Bolt type
- L: Long
- S: Short
- Packing type
- 1: Mix packing
- 2: Separation packing
- Cover Material
- C: Chromium plating
- Position
- 09: 9pin

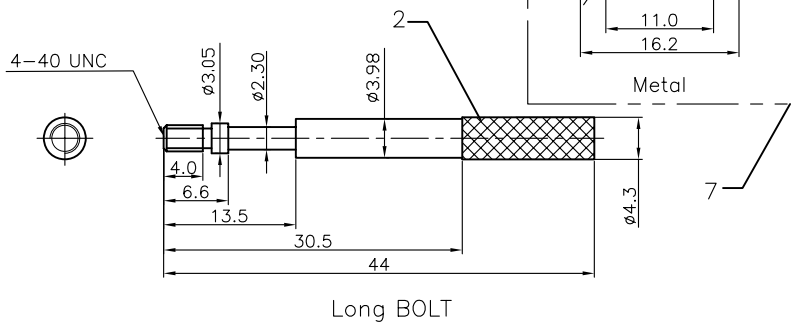
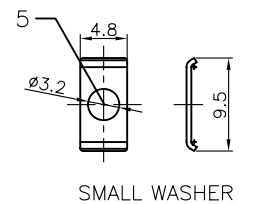
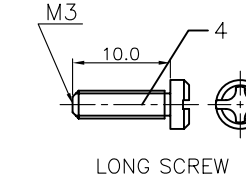
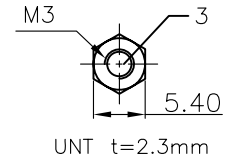
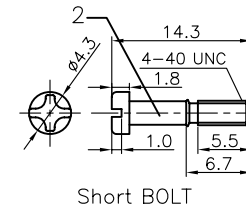
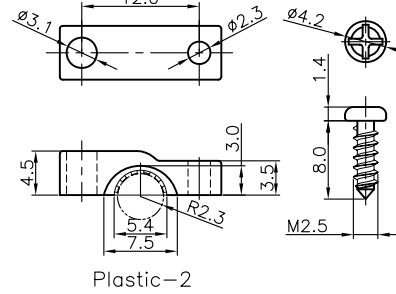
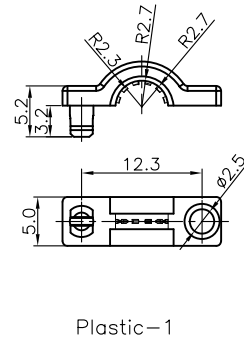
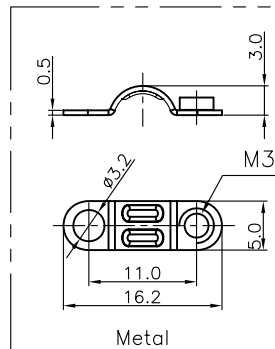
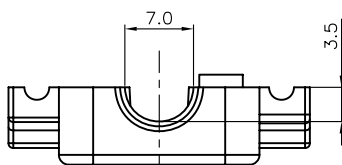
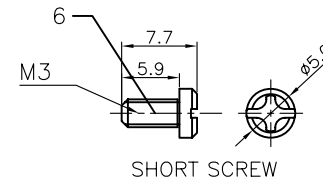
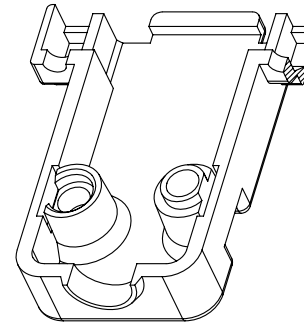
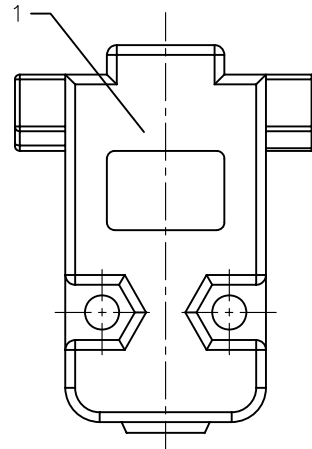
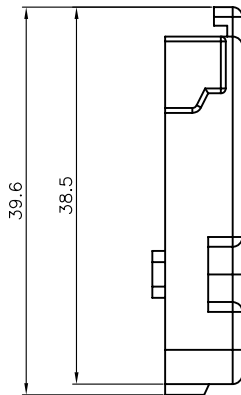
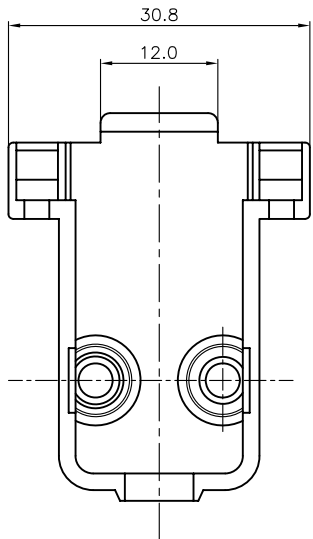
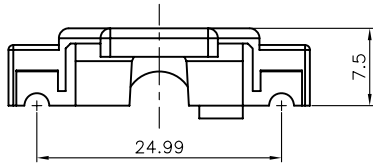

GENERAL TOLERANCE		ANGLE TOLERANCE		PROJECTION	TITLE
X.	±0.60	X.	±5°	mm	
.X	±0.38	.X	±3°	A4	
.XX	±0.25	.XX	±2°	SHEET SIZE	SERIES DS1046 SERIES
DRAWING TYPE		COSTOMER			
SCALE		1:1 SHEET 1 OF 1			
DRAWING NO.		C-DS1046-09XXXX-C			

晨翔电子有限公司  
CONNFLY CONNFLY ELECTRONIC CO. LTD

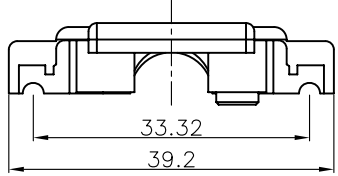

BOM LIST			
ITEM	PART NAME	Q'ty	NOTES
1	PLASTIC HOOD	2	ABS
2	2.1 LONG BOLT	2	#4-40
	2.2 SHORT BOLT	2	#4-40
3	NUT	2	M3
4	LONG SCREW	2	M3
5	SMALL WASHER	2	
6	SHORT SCREW	2	M3
7	7.1 METAL WASHER	2	M3
	7.2 PLASTIC-1 WASHER	2	ABS
	7.3 PLASTIC-2 WASHER	2	ABS

REV.	DESCRIPTION	DRAWN	CHECKED	APPROVED
A	NEW RELEASE	LJH 05/18/05'	~	LJC 05/18/05'
B	整理图面	YCH 09/13/07'	~	

NOTES:

1. PART NUMBER CODE:

DS1046 - 15 X X X X

- Washer type
- 1: Metal
- 2: Plastic-1(Lock type)
- 3: Plastic-2(Screw type)
- Bolt type
- L: Long
- S: Short
- Packing type
- 1: Mix packing
- 2: Separation packing
- Cover Material
- C: Chromium plating
- Position
- 15: 15pin

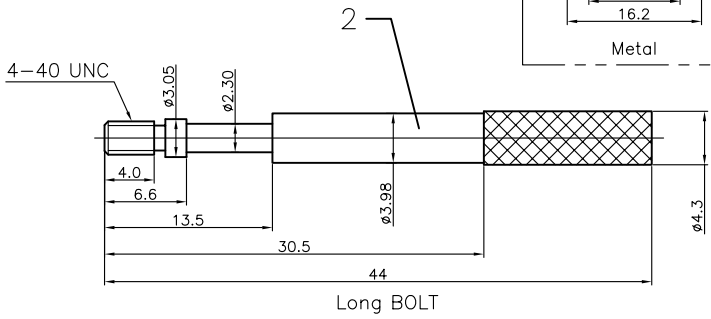
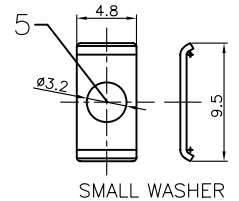
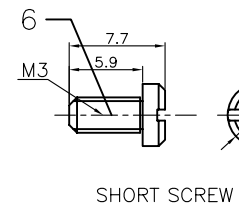
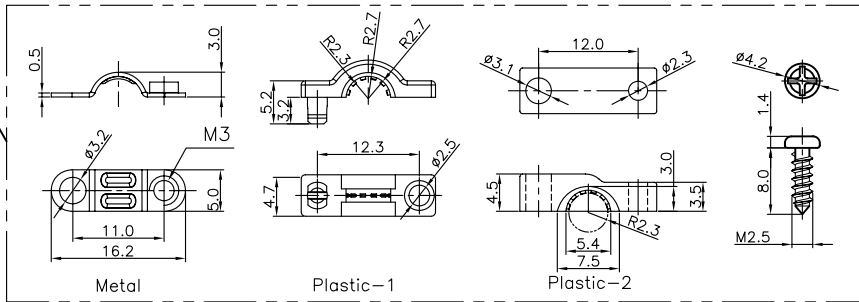
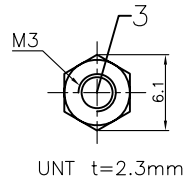
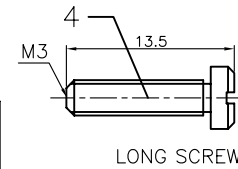
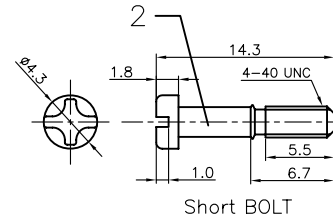
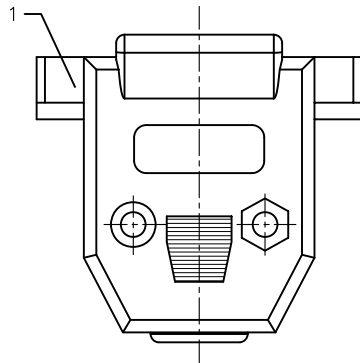
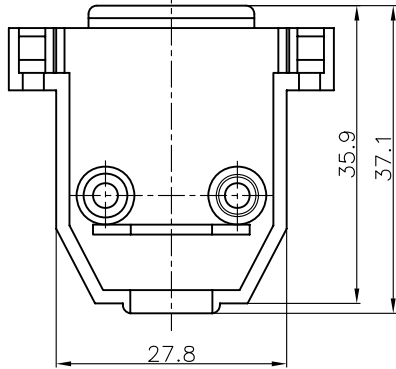
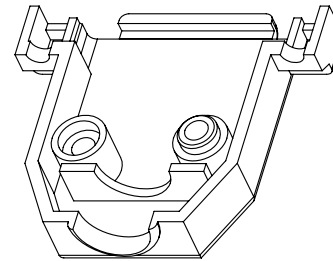

GENERAL TOLERANCE	ANGLE TOLERANCE
X. ±0.60	X. ±5°
.X ±0.38	.X ±3°
.XX ±0.25	.XX ±2°

PROJECTION	TITLE
UNITS mm	D-SUB 15pin Hood Chromium Plated
SHEET SIZE A4	SERIES DS1046 SERIES

DRAWING TYPE	COSTOMER
SCALE 1:1	SHEET 1 OF 1
DRAWING NO. C-DS1046-15XXXX	

 晨翔电子有限公司  
CONNFLY CONNFLY ELECTRONIC CO. LTD

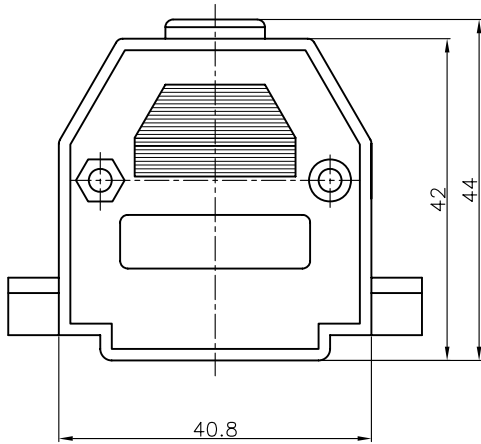
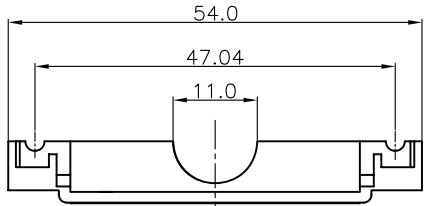

BOM LIST			
ITEM	PART NAME	Q'ty	NOTES
1	PLASTIC HOOD	2	ABS
2	2.1 LONG BOLT	2	#4-40
	2.2 SHORT BOLT	2	#4-40
3	NUT	2	M3
4	LONG SCREW	2	M3
5	SMALL WASHER	2	
6	SHORT SCREW	2	M3
7	7.1 METAL WASHER	2	M3
	7.2 PLASTIC-1 WASHER	2	ABS
	7.3 PLASTIC-2 WASHER	2	ABS

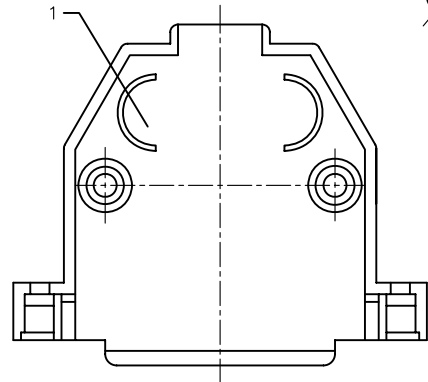
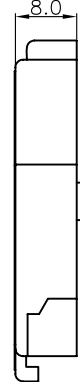

REV.	DESCRIPTION	DRAWN	CHECKED	APPROVED
A	NEW RELEASE	LJH 10/26/05'	~	LJC 10/26/05'
B	整理图画	YCH 09/13/07'	~	

NOTES:  
 1. PART NUMBER CODE:  
 DS1046 - 25 X X X X  
 Washer type  
 1: Metal  
 2: Plastic-1(Lock type)  
 3: Plastic-2(Screw type)  
 Bolt type  
 L: Long  
 S: Short  
 Packing type  
 1: Mix packing  
 2: Separation packing  
 Cover Material  
 C: Chromium plating  
 Position  
 25: 25pin

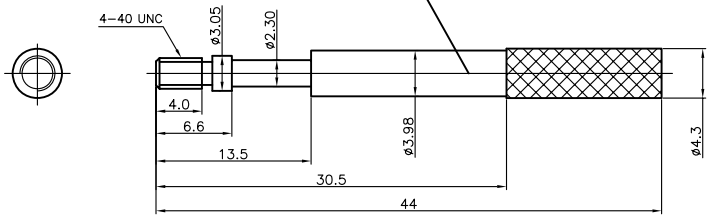
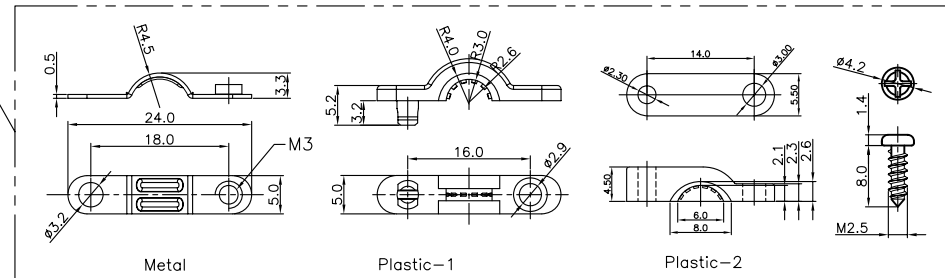
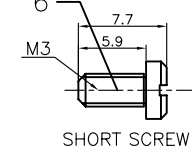
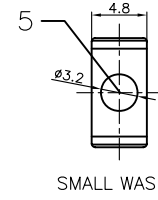
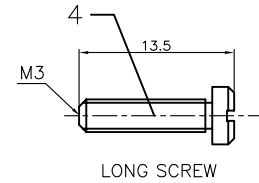
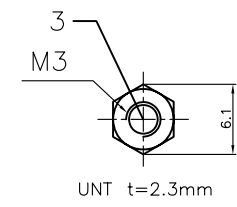
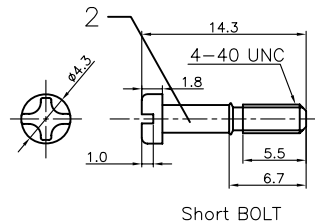

GENERAL TOLERANCE	ANGLE TOLERANCE	PROJECTION	TITLE
X. ±0.60	X. ±5°	UNITS	D-SUB 25pin Hood Chromium plated
.X ±0.38	.X ±3°	SHEET SIZE	SERIES DS1046 SERIES
.XX ±0.25	.XX ±2°		
DRAWING TYPE	COSTOMER	晨翔电子有限公司 <b>CONNFLY CONNFLY ELECTRONIC CO. LTD</b>	
SCALE	1:1 SHEET 1 OF 1		
DRAWING NO.	C-DS1046-25XXXX		

BOM LIST			
ITEM	PART NAME	Q'ty	NOTES
1	PLASTIC HOOD	2	ABS
2	LONG BOLT	2	#4-40
	SHORT BOLT	2	#4-40
3	NUT	2	M3
4	LONG SCREW	2	M3
5	SMALL WASHER	2	
6	SHORT SCREW	2	M3
7	METAL WASHER	2	M3
	PLASTIC-1 WASHER	2	ABS
	PLASTIC-2 WASHER	2	ABS

REV.	DESCRIPTION	DRAWN	CHECKED	APPROVED
A	NEW RELEASE	LJH 10/26/05'	~	LJC 10/26/05'
B	整理图画	YCH 09/13/07'	~	

NOTES:

1. PART NUMBER CODE:

DS1046 - 37 X X X X

- Washer type
- 1: Metal
- 2: Plastic-1(Lock type)
- 3: Plastic-2(Screw type)
- Bolt type
- L: Long
- S: Short
- Packing type
- 1: Mix packing
- 2: Separation packing
- Cover Material
- C: Chromium plating
- Position
- 37: 37pin

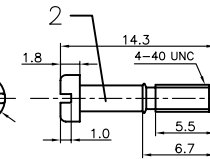
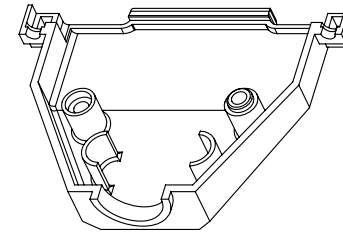

Short BOLT

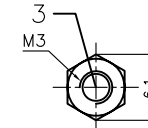

UNT t=2.3mm

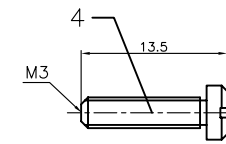

LONG SCREW

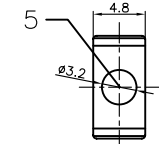

SMALL WASHER

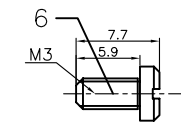

SHORT SCREW

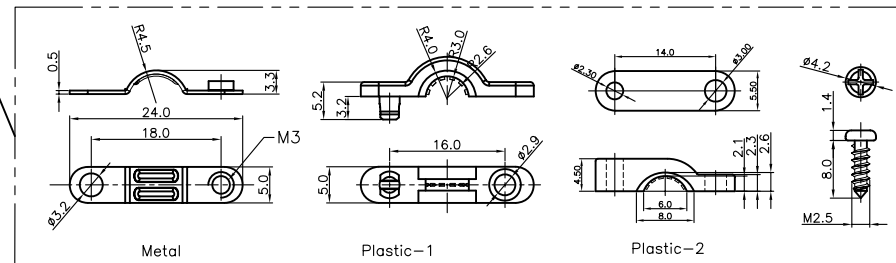

Metal

Plastic-1

Plastic-2

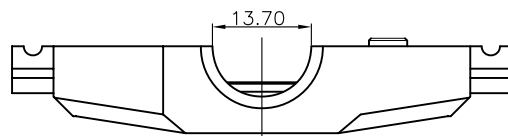
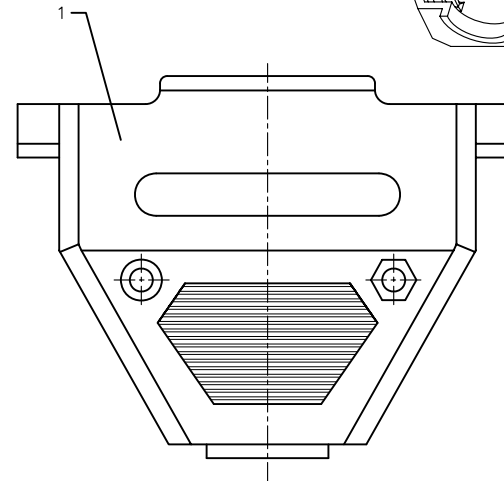
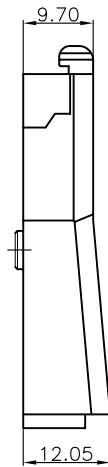
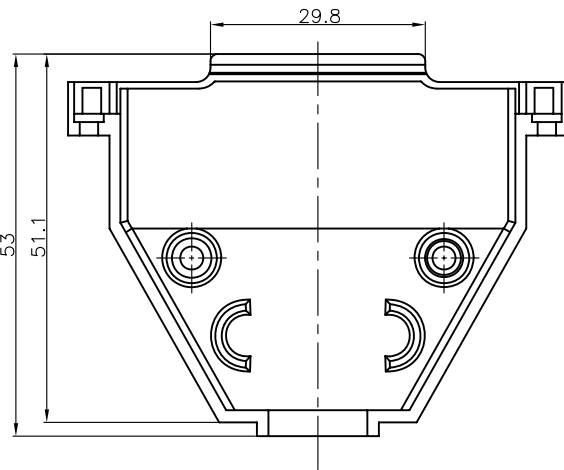
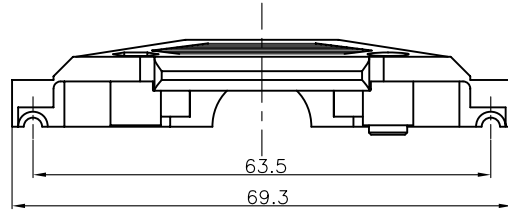

Long BOLT

GENERAL TOLERANCE	ANGLE TOLERANCE
X. ±0.60	X. ±5°
.X ±0.38	.X ±3°
.XX ±0.25	.XX ±2°

PROJECTION	TITLE
	D-SUB 37pin Hood Chromium plated
UNITS	mm
SHEET SIZE	A4
SERIES	DS1046 SERIES

DRAWING TYPE	COSTOMER
SCALE	1:1 SHEET 1 OF 1
DRAWING NO.	C-DS1046-37XXXX

晨翔电子有限公司  
CONNFLY CONNFLY ELECTRONIC CO. LTD

REV.	DESCRIPTION	DRAWN	CHECKED	APPROVED
A	NEW RELEASE	YCH 12/21/09'	~	

NOTES:  
1. PART NUMBER CODE:  
DS1050 - 15 X X

Packing type  
1: Mix packing  
2: Separation packing  
Cover Material  
N: Nickel plating  
Position  
15: 15pin

BOM LIST			
ITEM	PART NAME	Q'ty	NOTES
1	PLASTIC HOOD-1	1	ABS
2	PLASTIC HOOD-2	1	ABS
3	SR	1	ABS
4	SEAL BLOCK	1	ABS
5	SHORT SCREW	2	M3
6	LONG SCREW	3	M3
7	BOLT	2	UNC #4-40
8	WASHER	2	M2.5
9	STRAIN RELIEF	1	

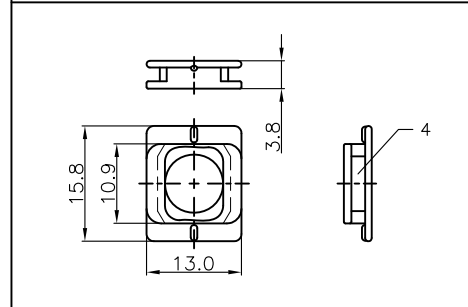
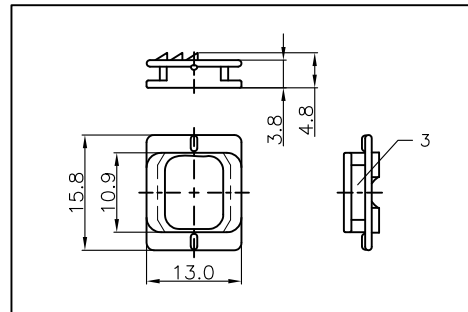
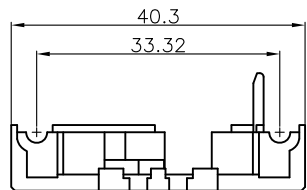
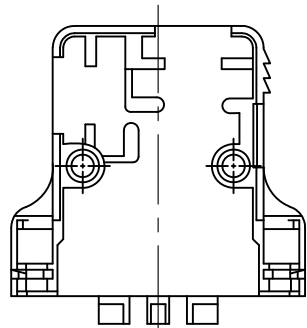
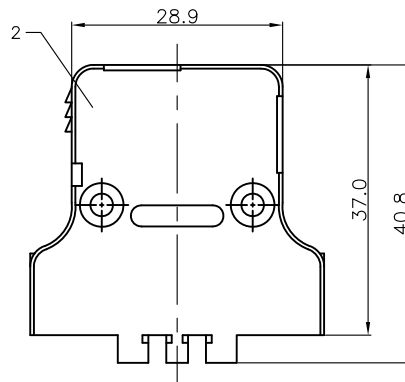
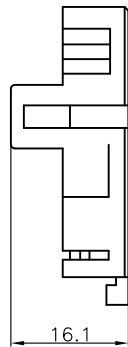
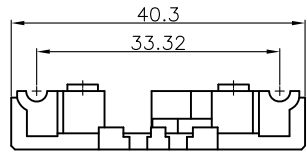
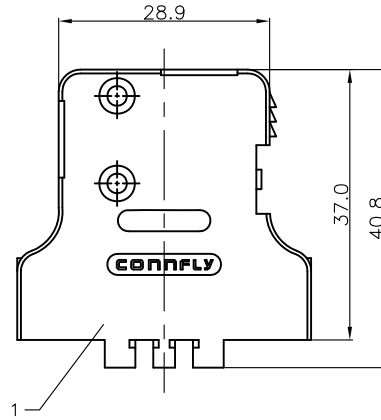
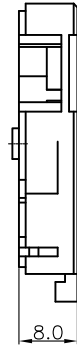
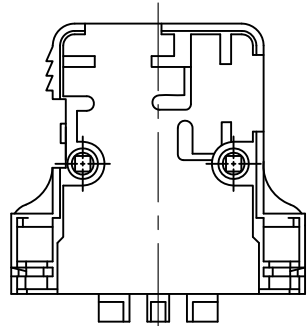
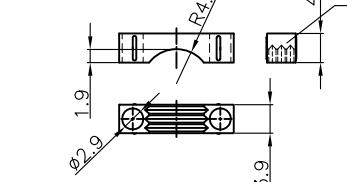
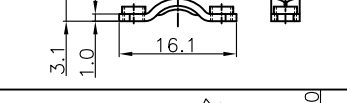
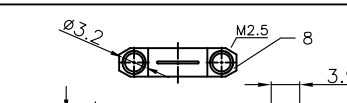
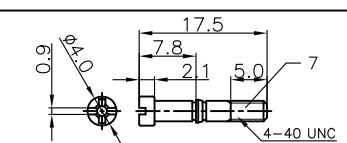
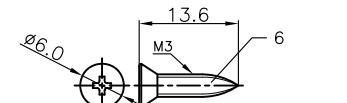
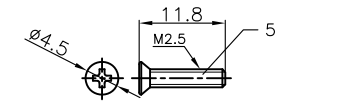

GENERAL TOLERANCE	ANGLE TOLERANCE
X. ±0.60	X. ±5°
.X ±0.38	.X ±3°
.XX ±0.25	.XX ±2°

PROJECTION	TITLE
UNITS	mm
SHEET SIZE	A4

D-SUB 90°/180° Hoods	
Ninkel plated	
SERIES	DS1050 SERIES

DRAWING TYPE	COSTOMER		
SCALE	1:1	SHEET	1 OF 1
DRAWING NO.	C-DS1050-15XX		

 晨翔电子有限公司  
**CONNFLY CONNFLY ELECTRONIC CO. LTD**

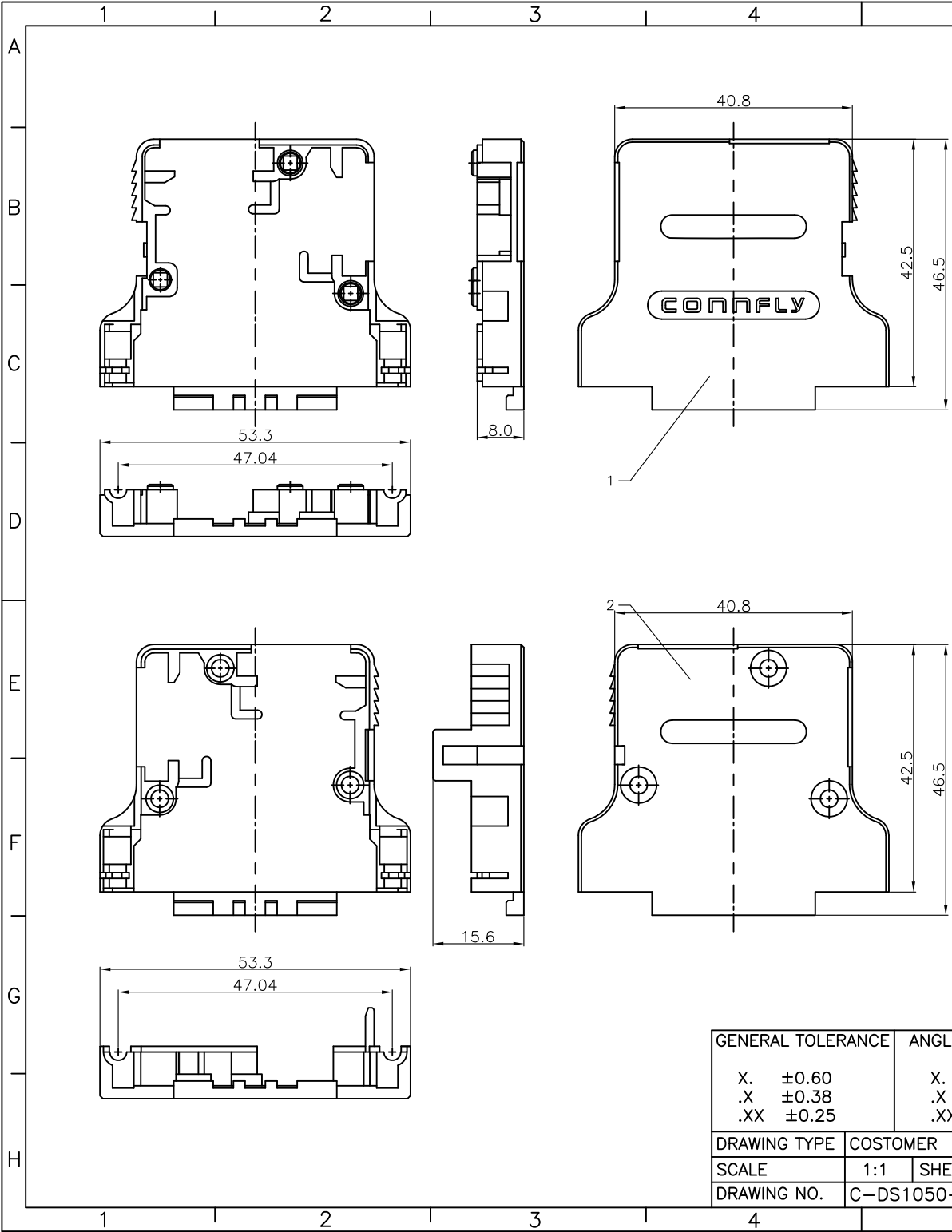

REV.	DESCRIPTION	DRAWN	CHECKED	APPROVED
A	NEW RELEASE	YCH 12/21/09'	~	

NOTES:  
 1. PART NUMBER CODE:  
 DS1050 - 25 X X

Packing type  
 1: Mix packing  
 2: Separation packing  
 Cover Material  
 N: Nickel plating  
 Position  
 25: 25pin

BOM LIST			
ITEM	PART NAME	Q'ty	NOTES
1	PLASTIC HOOD-1	1	ABS
2	PLASTIC HOOD-2	1	ABS
3	SR	1	ABS
4	SEAL BLOCK	1	ABS
5	SHORT SCREW	2	M2.5
6	LONG SCREW	3	M3
7	BOLT	2	UNC #4-40
8	WASHER	2	M2.5

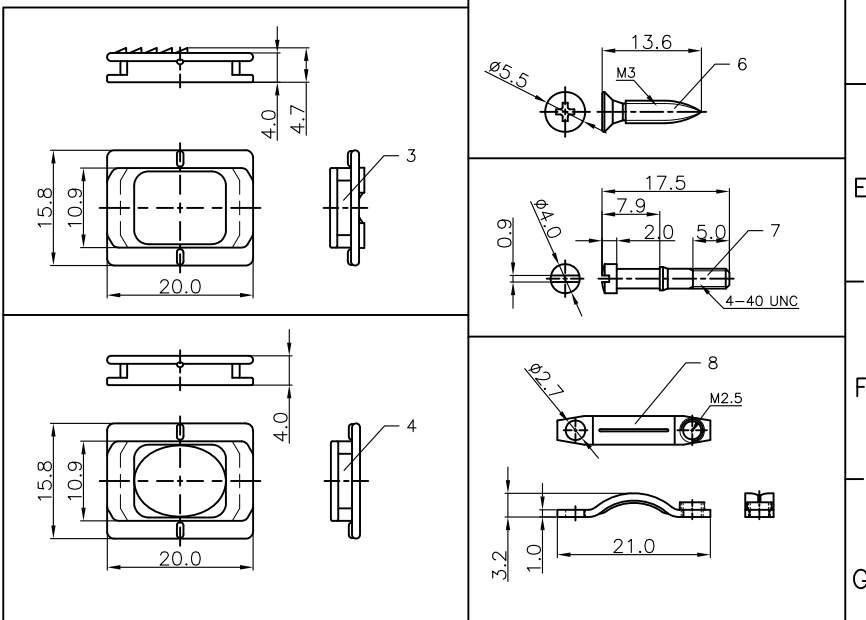

GENERAL TOLERANCE		ANGLE TOLERANCE		PROJECTION		TITLE	D-SUB 90°/180° Hoods	
X.	±0.60	X.	±5°	UNITS	mm		Ninkel plated	
.X	±0.38	.X	±3°	SHEET SIZE	A4	SERIES	DS1050 SERIES	
.XX	±0.25	.XX	±2°	<b>晨翔电子有限公司</b> <b>CONFLY CONFLY ELECTRONIC CO. LTD</b>				
DRAWING TYPE		COSTOMER						
SCALE	1:1	SHEET	1 OF 1					
DRAWING NO.		C-DS1050-25XX						

REV.	DESCRIPTION	DRAWN	CHECKED	APPROVED
A	NEW RELEASE	LJH 08/13/05'	~	LJC 08/13/05'
B	整理图面	YCH 09/13/07'	~	

NOTES:

1. PART NUMBER CODE:

DS1051 - 09 X X

Packing type  
 1: Mix packing  
 2: Separation packing  
 Cover Material  
 C: Chromium plating  
 Position  
 09: 9pin

BOM LIST			
ITEM	PART NAME	Q'ty	NOTES
1	PLASTIC HOOD-1	1	ABS
2	PLASTIC HOOD-1	1	ABS
3	WASHER	2	M3
4	BOLT	2	#4-40
5	NUT	2	M3
6	SHORT SCREW	2	M3
7	LONG SCREW	2	M3

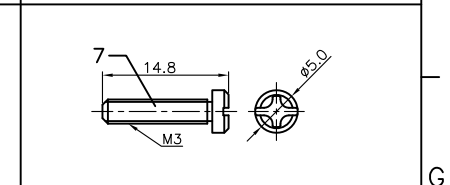
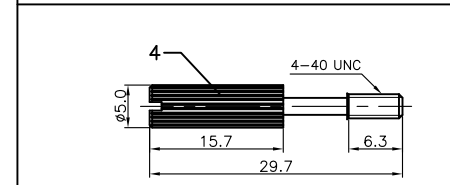
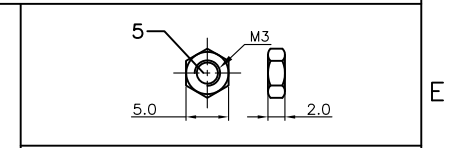
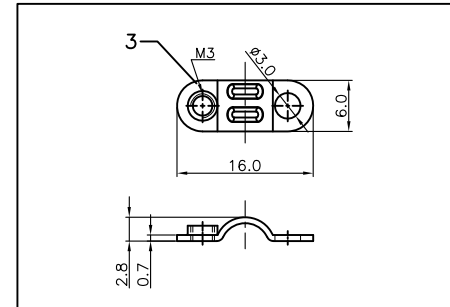
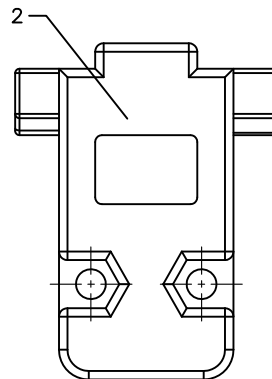
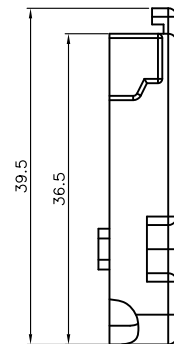
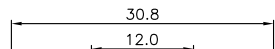
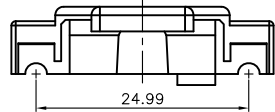
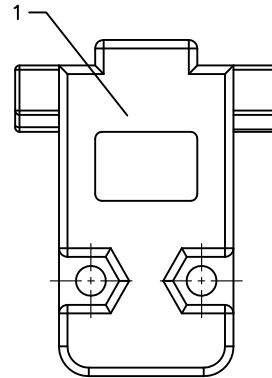
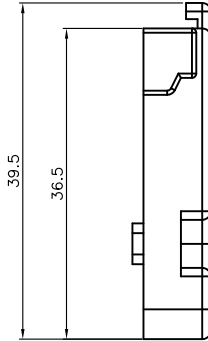
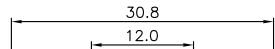
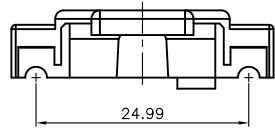

GENERAL TOLERANCE	ANGLE TOLERANCE	PROJECTION	UNIT	TITLE	D-SUB 9pin Hood Chromium Plated Large Angled Cable Outlet
X. ±0.60 .X ±0.38 .XX ±0.25	X. ±5° .X ±3° .XX ±2°	mm	A4	SERIES DS1051 SERIES	
DRAWING TYPE	COSTOMER		 <b>晨翔电子有限公司</b> <b>CONNFLY CONNFLY ELECTRONIC CO. LTD</b>		
SCALE	1:1	SHEET 1 OF 1			
DRAWING NO.	C-DS1051-09XX				

REV.	DESCRIPTION	DRAWN	CHECKED	APPROVED
A	NEW RELEASE	LJH 10/26/05'	~	LJC 10/26/05'
B	整理图面	YCH 09/13/07'	~	

NOTES:  
1. PART NUMBER CODE:  
DS1051 - 25 X X

Packing type  
1: Mix packing  
2: Separation packing  
Cover Material  
C: Chromium plating  
Position  
25: 25pin

BOM LIST			
ITEM	PART NAME	Q'ty	NOTES
1	PLASTIC HOOD-1	1	ABS
2	PLASTIC HOOD-1	1	ABS
3	WASHER	2	M3
4	BOLT	2	#4-40
5	NUT	2	M3
6	SHORT SCREW	2	M3
7	LONG SCREW	2	M3

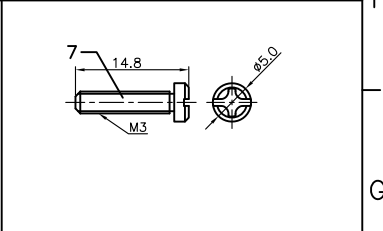
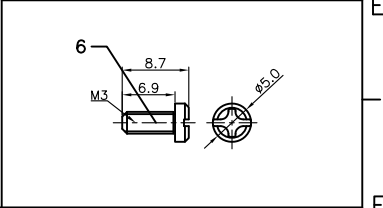
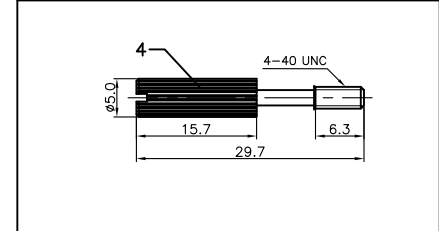
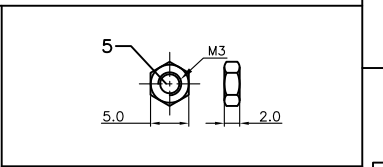
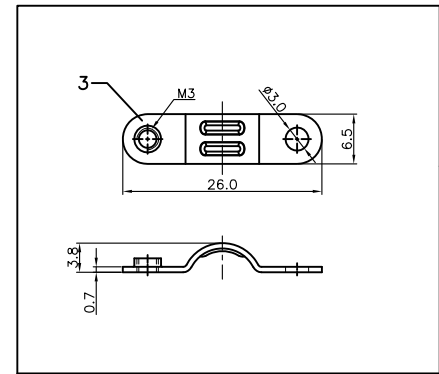
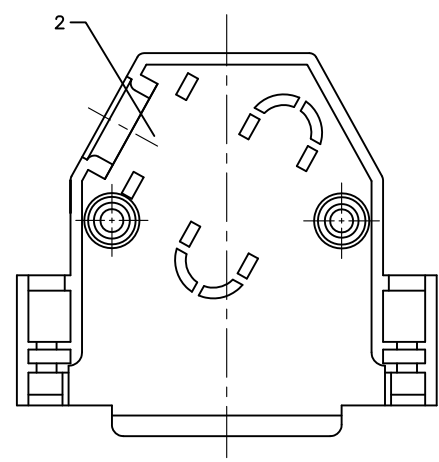
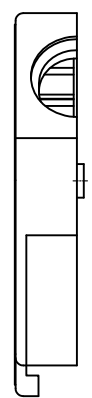
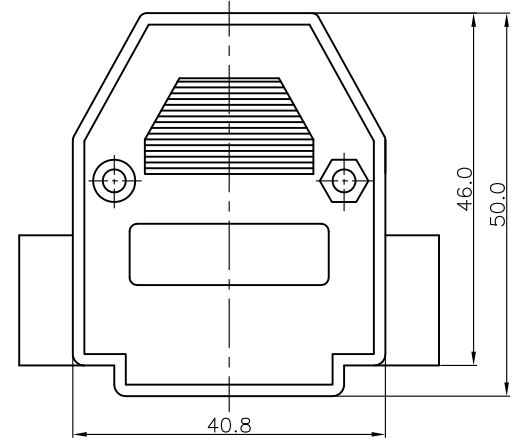
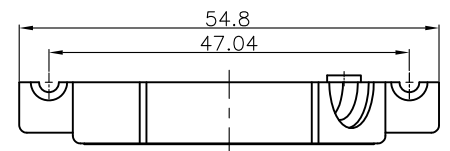
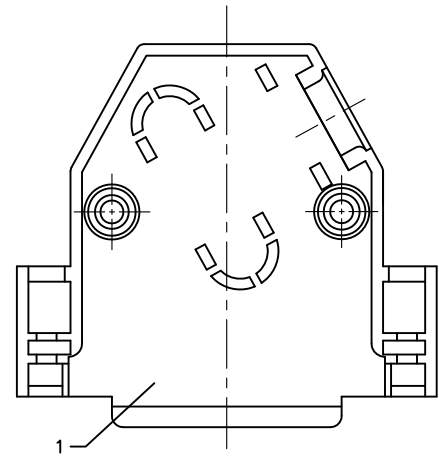
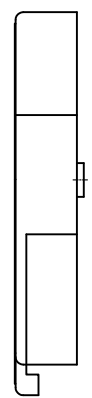
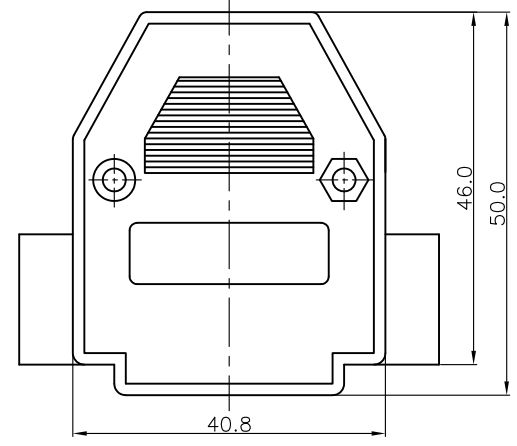
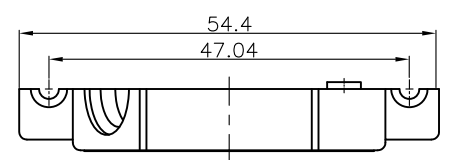

GENERAL TOLERANCE	ANGLE TOLERANCE
X. ±0.60	X. ±5°
.X ±0.38	.X ±3°
.XX ±0.25	.XX ±2°

PROJECTION	TITLE
	D-SUB 25pin Hood Chromium plated Large Angled Cable Outlet
UNITS	mm
SHEET SIZE	A4
SERIES	DS1051 SERIES

DRAWING TYPE	COSTOMER
SCALE	1:1 SHEET 1 OF 1
DRAWING NO.	C-DS1051-25XX

晨翔电子有限公司  
CONNFLY CONNFLY ELECTRONIC CO. LTD



REV.	DESCRIPTION	DRAWN	CHECKED	APPROVED
A	NEW RELEASE	LJH 10/26/05'	~	LJC 10/26/05'
B	整理图面	YCH 09/13/07'	~	

NOTES:

1. PART NUMBER CODE:

DS1051 - 37 X X

Packing type  
 1: Mix packing  
 2: Separation packing  
 Cover Material  
 C: Chromium plating

Position  
 37: 37pin

BOM LIST			
ITEM	PART NAME	Q'ty	NOTES
1	PLASTIC HOOD-1	1	ABS
2	PLASTIC HOOD-1	1	ABS
3	WASHER	2	M3
4	BOLT	2	#4-40
5	NUT	2	M3
6	SHORT SCREW	2	M3
7	LONG SCREW	2	M3

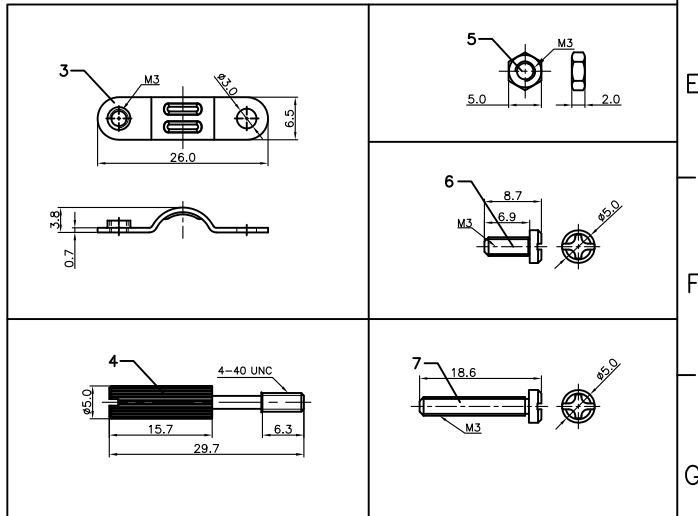
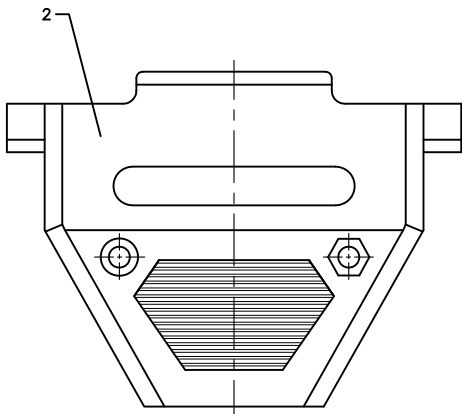
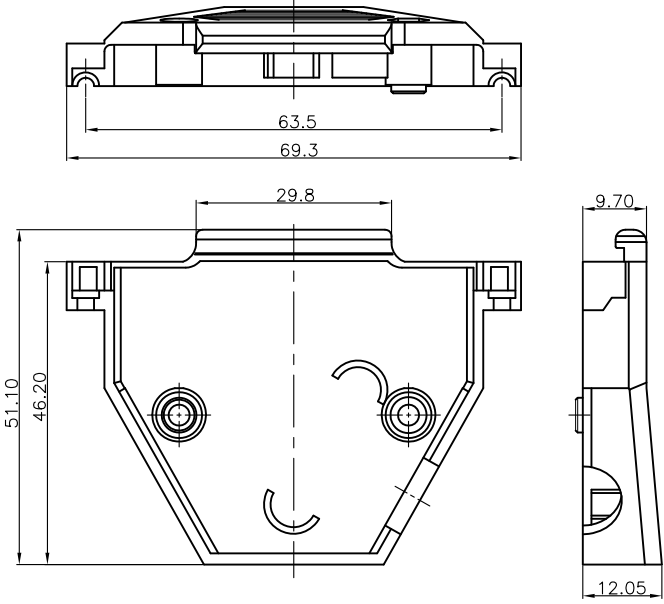
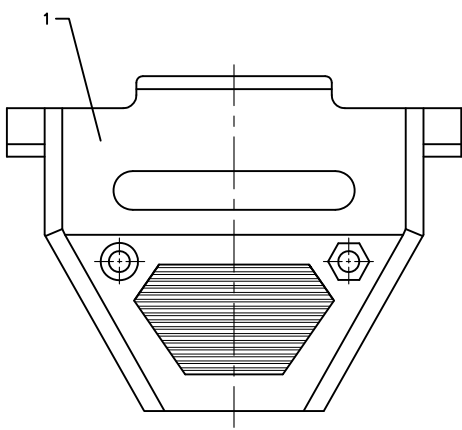
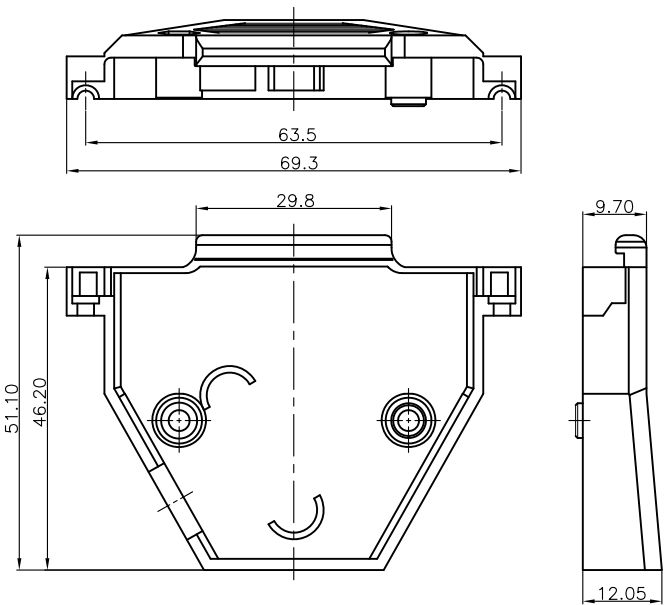

GENERAL TOLERANCE		ANGLE TOLERANCE	
X.	±0.60	X.	±5°
.X	±0.38	.X	±3°
.XX	±0.25	.XX	±2°

PROJECTION		TITLE	D-SUB 37pin Hood Chromium plated
UNITS	mm		Large Angled Cable Outlet
SHEET SIZE	A4	SERIES	DS1051 SERIES

DRAWING TYPE	COSTOMER		
SCALE	1:1	SHEET	1 OF 1
DRAWING NO.	C-DS1051-37XX		

晨翔电子有限公司  
**CONNFLY CONNFLY ELECTRONIC CO. LTD**

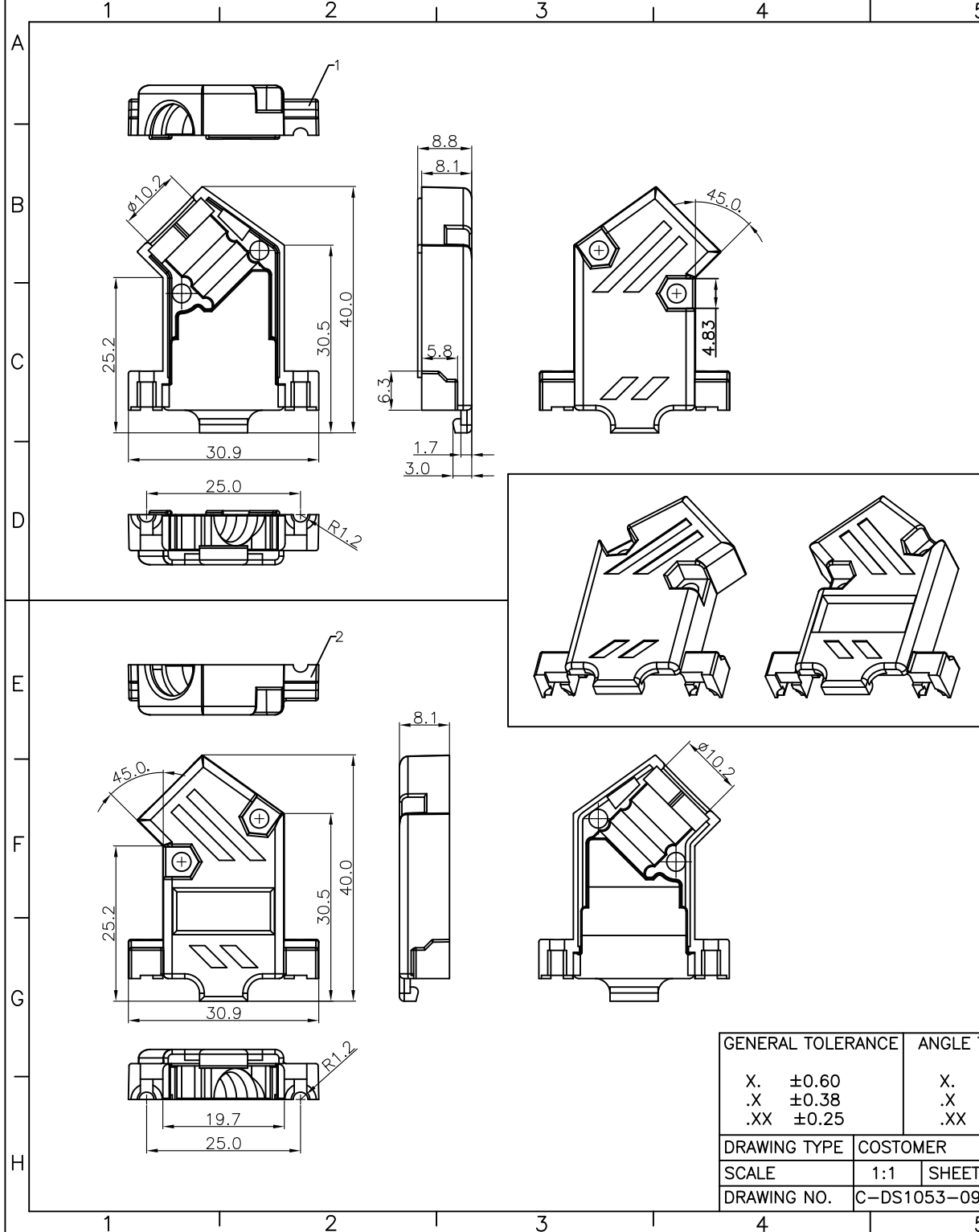

REV.	DESCRIPTION	DRAWN	CHECKED	APPROVED
A	NEW RELEASE	YCH 06/18/12'	~	

NOTES:  
 1. Hardwares are all Nickel plated.  
 2. PART NUMBER CODE:  
 DS1053 - XX X X X

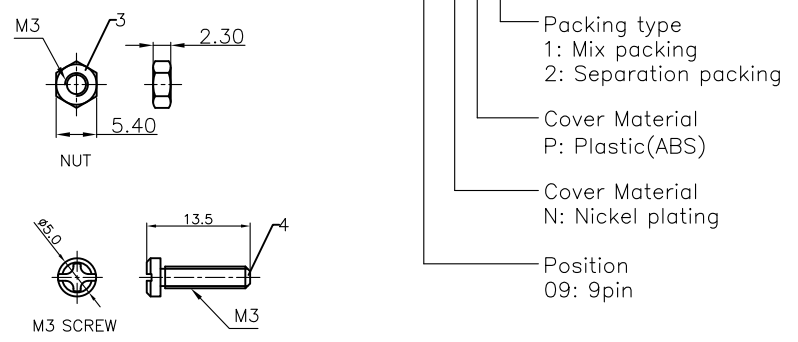

Packing type  
 1: Mix packing  
 2: Separation packing  
 Cover Material  
 P: Plastic(ABS)  
 N: Nickel plating  
 Position  
 09: 9pin

BOM LIST			
ITEM	PART NAME	Q'ty	NOTES
1	PLASTIC HOOD-1	1	ABS
2	PLASTIC HOOD-2	1	ABS
3	NUT	2	M3
4	M3 SCREW	2	M3
5	SHORT BOLT	2	UNC #4-40

GENERAL TOLERANCE	ANGLE TOLERANCE	PROJECTION	TITLE	D-SUB 9pin Hood 45' OUT CABLE NICKEL PLATING TYPE		
X. ±0.60	X. ±5°	UNITS	mm	SHEET SIZE	A4	
.X ±0.38	.X ±3°	SHEET SIZE	A4	SERIES	DS1053 SERIES	
.XX ±0.25	.XX ±2°					
DRAWING TYPE	COSTOMER					
SCALE	1:1					SHEET
DRAWING NO.	C-DS1053-09XXX-A		<b>CONNFLY ELECTRONIC CO. LTD</b>			

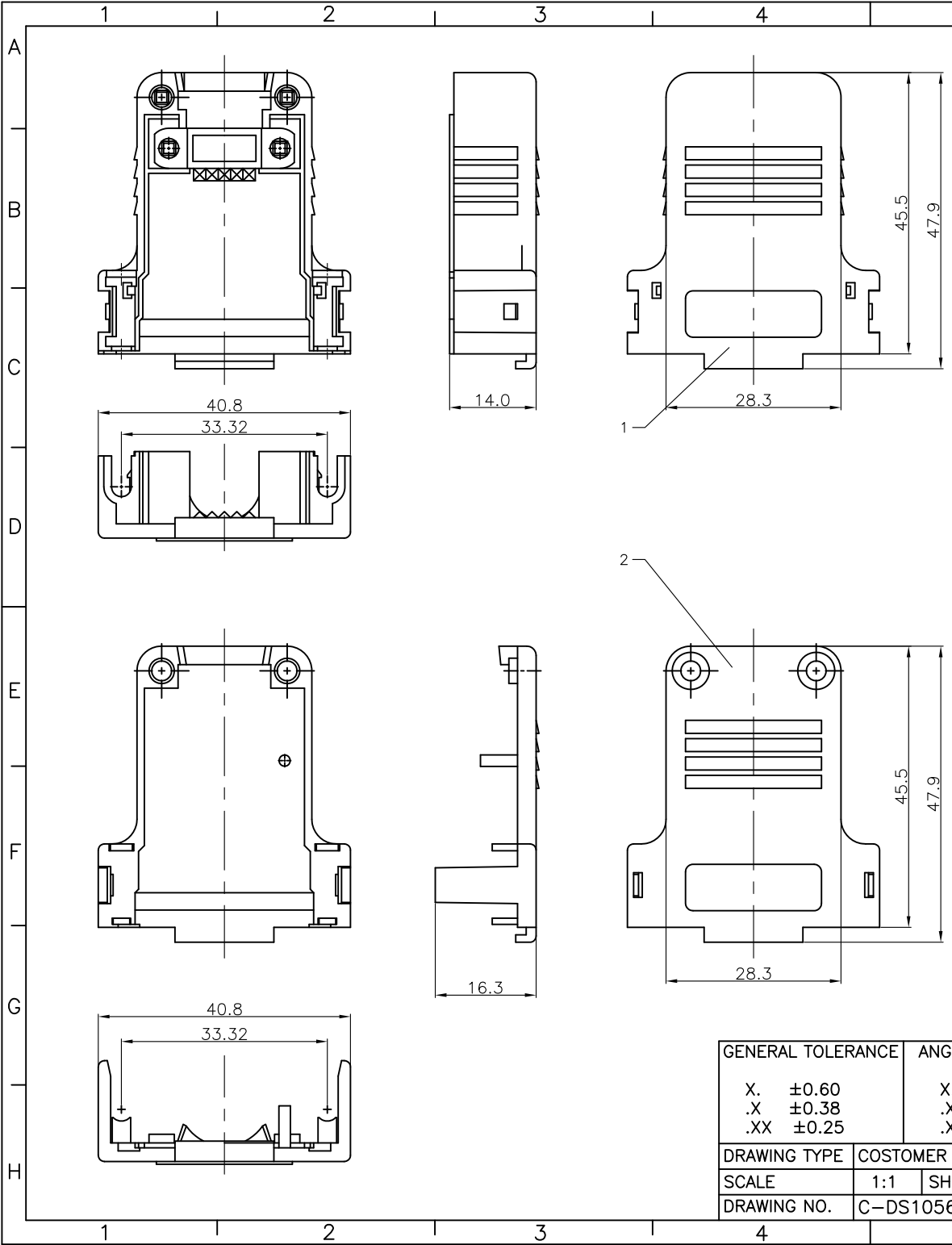

REV.	DESCRIPTION	DRAWN	CHECKED	APPROVED
A	NEW RELEASE	YCH 12/21/09'	~	

NOTES:  
 1. PART NUMBER CODE:  
 DS1056 - 15 X X

Packing type  
 1: Mix packing  
 2: Separation packing  
 Cover Material  
 N: Nickel plating  
 Position  
 15: 15pin

BOM LIST			
ITEM	PART NAME	Q'ty	NOTES
1	PLASTIC HOOD-1	1	ABS
2	PLASTIC HOOD-2	1	ABS
3	PLASTIC WASHER	1	ABS
4	METAL WASHER	1	
5	SHORT SCREW	2	M3
6	LONG SCREW	2	M3
7	BOLT	2	UNC #4-40

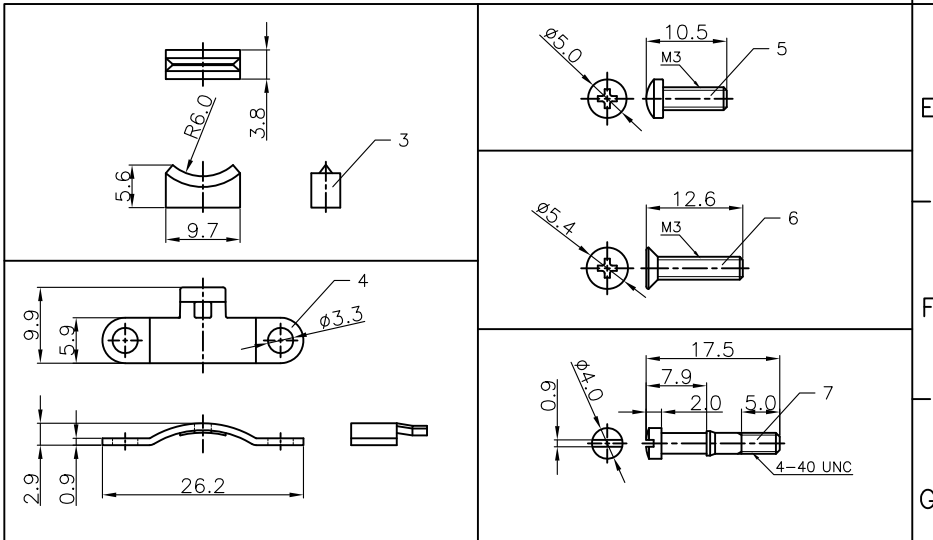

GENERAL TOLERANCE		ANGLE TOLERANCE		PROJECTION		TITLE	D-SUB 15pin Hood Ninkel plated		
X.	±0.60	X.	±5°	UNITS	mm	SHEET SIZE	A4	SERIES	DS1056 SERIES
.X	±0.38	.X	±3°						
.XX	±0.25	.XX	±2°						
DRAWING TYPE		COSTOMER				晨翔电子有限公司 <b>CONNFLY CONNFLY ELECTRONIC CO. LTD</b>			
SCALE		1:1	SHEET	1 OF 1					
DRAWING NO.		C-DS1056-15XX							