

REV.	DESCRIPTION	DRAWN	CHECKED	APPROVED
A	NEW RELEASE	YCH 09/04/08'	~	

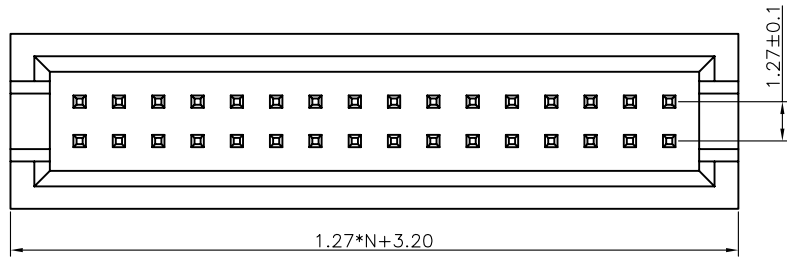

NOTES:

- MATERIAL
 - INSULATOR:THERMOPLASTIC(UL 94V-0).
 - CONTACT MATERIAL:COPPER ALLOY.
- SPECIFICATION
 - CURRENT RATING:1.0 Amp.
 - INSULATION RESISTANCE:1000MΩ Min.
 - DIELECTRIC WITHSTANDING:300VAC.
 - CONTACT RESISTANCE:20mΩ Max.
 - OPERATING TEMPERATURE:-40°C TO+105°C.

3. PART NUMBER: DS1031-15

4. PRODUCT NUMBER CODE:

DS1031-15 - X X X X

- HOUSING COLOR
B: BLACK
- CONTACT PLATING
8: FULL GOLD FLASH
6: FULL TIN
- MOUNTING TYPE
V: STRAIGHT TYPE
- No.OF CONTACTS
06 ~ 40

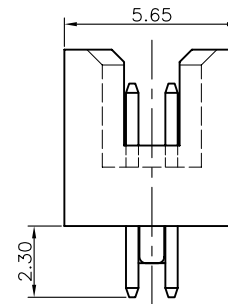
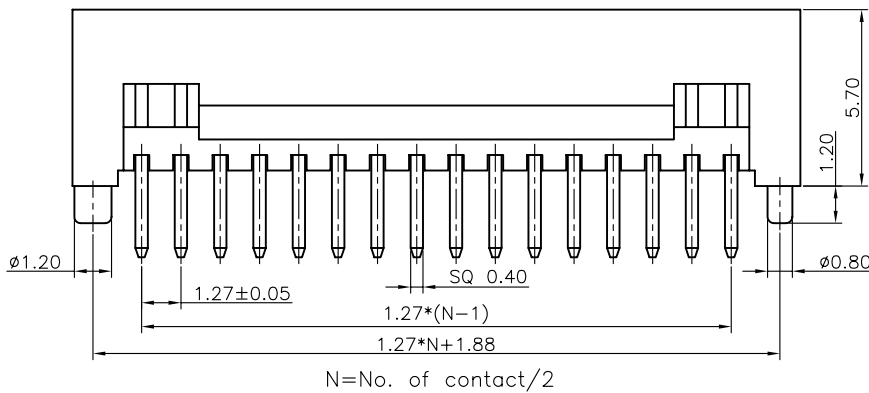

N=No. of contact/2

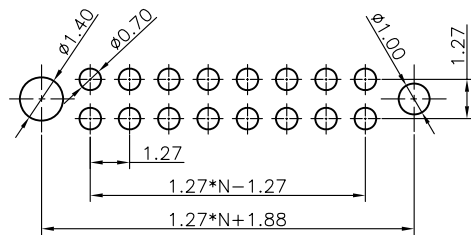

RECOMMEND PCB LAYOUT(TOLERANCE=±0.05)

GENERAL TOLERANCE		ANGLE TOLERANCE		PROJECTION		TITLE	BOX HEADER PITCH 1.27mm	
X.	±0.60	X.	±5°	UNITS	mm		V/T TYPE	
.X	±0.38	.X	±3°	SHEET SIZE	A4	SERIES	DS1031-15 SERIES	
.XX	±0.25	.XX	±2°	晨翔电子有限公司 CONNFLY CONNFLY ELECTRONIC CO. LTD				
DRAWING TYPE		CUSTOMER						
SCALE	1:1	SHEET	1 OF 1					
DRAWING NO.		C-DS1031-15-XXXX						

REV.	DESCRIPTION	DRAWN	CHECKED	APPROVED
A	NEW RELEASE	LL 09/11/06'		

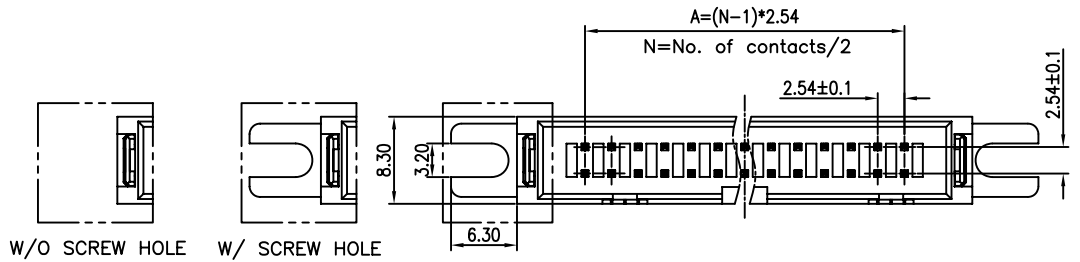

- NOTES:
- MATERIAL
 - INSULATOR: THERMOPLASTIC (UL 94V-0).
 - CONTACT: COPPER ALLOY.
 - SPECIFICATION
 - STORAGE TEMPERATURE: $-40^{\circ}\text{C} \sim +105^{\circ}\text{C}$.
 - CONTACT RESISTANCE: $20\text{m}\Omega$ max.
 - INSULATION RESISTANCE: 10000Ω min.
 - DIELECTRIC WITHSTANDING VOLTAGE: AC 500V PER MINUTE.

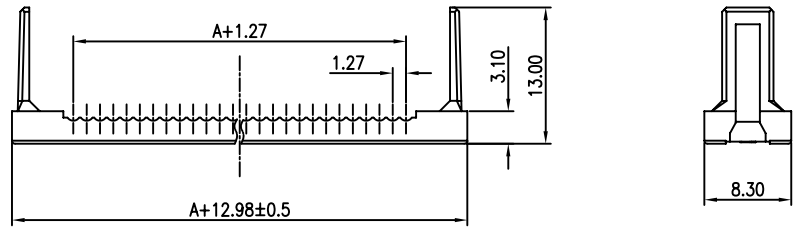
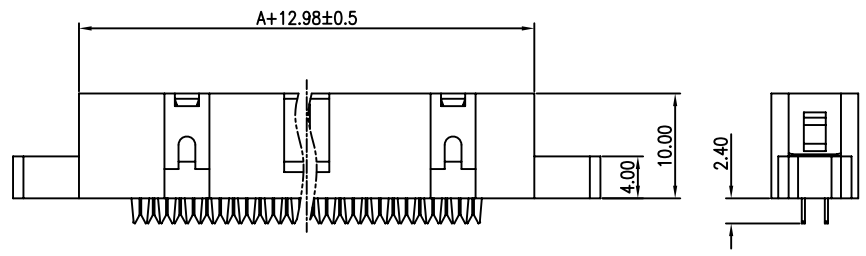

- PART NUMBER: DS1015
- PRODUCT NUMBER CODE:
 DS1015- X X X X X
 HOUSING COLOR
 A: GRAY
 B: Black
 CONTACT PLATING
 O: SELECTIVE GOLD FLASH
 STRAIN RELIEF
 M: W/
 N: W/O
 SCREW HOLE
 M: W/
 N: W/O
 No. OF CONTACTS
 10 14 16 20 24 26
 30 34 40 50 60 64
 SERIES No.
 DS1015

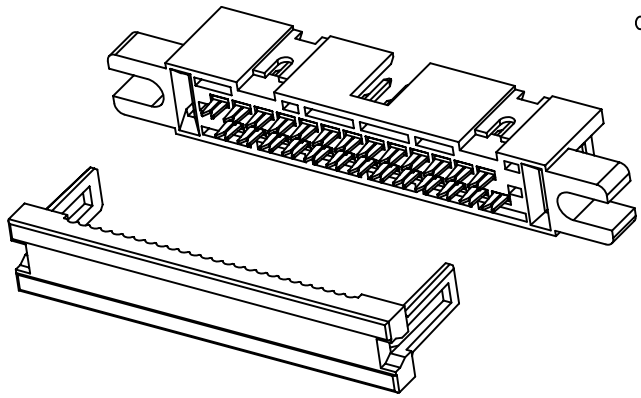

GENERAL TOLERANCE	ANGLE TOLERANCE
X. ± 0.60	X. $\pm 5^{\circ}$
.X ± 0.38	.X $\pm 3^{\circ}$
.XX ± 0.25	.XX $\pm 2^{\circ}$

PROJECTION	TITLE	UNITS	SHEET SIZE	SERIES
	INDC BOX HEADER MATES WITH PITCH 1.27mm FLAT CABLE	mm	A4	DS1015 SERIES

DRAWING TYPE	CUSTOMER
SCALE	1:1 SHEET 1 OF 1
DRAWING NO.	C-DS1015-XXXX

晨翔电子有限公司
CONNFLY CONNFLY ELECTRONIC CO. LTD

REV.	DESCRIPTION	DRAWN	CHECKED	APPROVED
A	NEW RELEASE	YCH 09/04/08'	~	

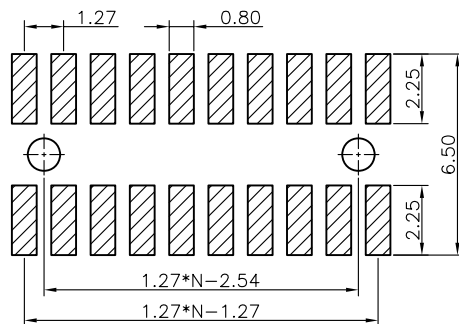
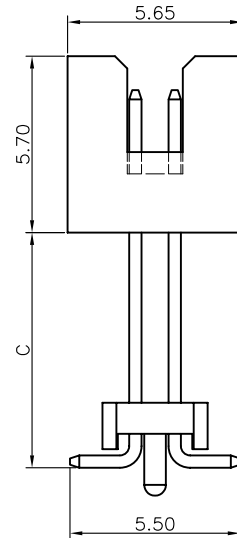
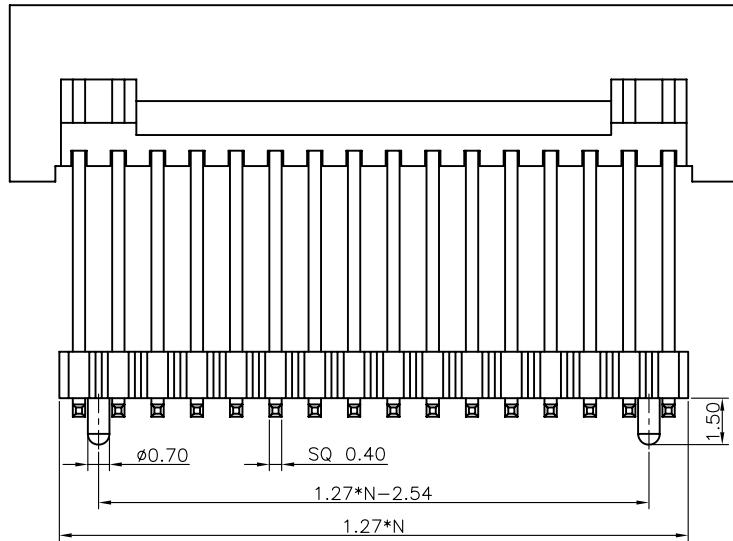
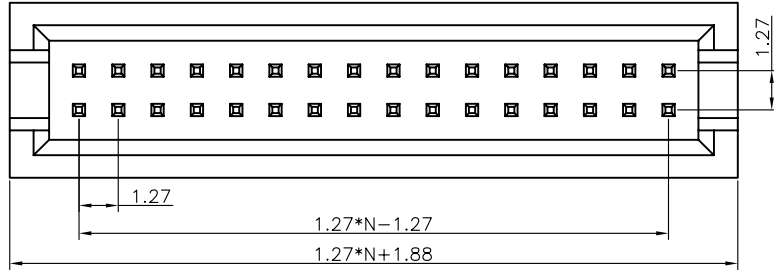

NOTES:

- MATERIAL
 - INSULATOR:THERMOPLASTIC(UL 94V-0).
 - CONTACT MATERIAL:COPPER ALLOY.
- SPECIFICATION
 - CURRENT RATING:1.0 Amp.
 - INSULATION RESISTANCE:1000MΩ Min.
 - DIELECTRIC WITHSTANDING:300VAC.
 - CONTACT RESISTANCE:30mΩ Max.
 - OPERATING TEMPERATURE:-40°C TO+105°C.

3. PART NUMBER: DS1031-13

4. PRODUCT NUMBER CODE:

DS1031-13 - X X X X X

- DIM. C
- 1:TYPE 1
- HOUSING COLOR
- B:BLACK
- CONTACT PLATING
- 8: FULL GOLD FLASH
- 6: FULL TIN
- MOUNTING TYPE
- S:SMT TYPE
- No.OF CONTACTS
- 2*3-2*40

TYPE	DIM C
1	7.60
2	
3	
4	
5	

RECOMMEND PCB LAYOUT(TOLERANCE=±0.05)

GENERAL TOLERANCE		ANGLE TOLERANCE		PROJECTION	⊕	TITLE
X.	±0.60	X.	±5°	UNITS	mm	1.27mm PIN HEADER SMT TYPE STACK SERIES
.X	±0.38	.X	±3°	SHEET SIZE	A4	SERIES DS1031-13 SERIES
.XX	±0.25	.XX	±2°			
DRAWING TYPE		CUSTOMER		 晨翔电子有限公司 CONNFLY CONNFLY ELECTRONIC CO. LTD		
SCALE		1:1 SHEET 1 OF 1				
DRAWING NO.		C-DS1031-13-XXXXXX				

REV.	DESCRIPTION	DRAWN	CHECKED	APPROVED
A	NEW RELEASE	LJH 04/27/05'		

NOTES:

- MATERIAL
 - INSULATOR:THERMOPLASTIC(UL 94V-0).
 - CONTACT: COPPER ALLOY.
- SPECIFICATION
 - TEMPERATURE:-40°C~+105°C.
 - CONTACT RESISTANCE:20mΩ max.(initial).
 - INSULATION RESISTANCE:1000MΩ min.
 - DIELECTRIC WITHSTANDING VOLTAGE:AC 500V PER MINUTE.

- PART NUMBER: DS1014
- PRODUCT NUMBER CODE:

DS1014- X X X X

- HOUSING COLOR
 - B: BLACK
 - W: WHITE
 - L: BLUE
 - A: GRAY
- CONTACT PLATING
 - F1: FULL GOLD FLASH
- MOUNTING TYPE
 - S: V/T TYPE
 - R: R/A TYPE
 - E: Elevator TYPE
- No.OF CONTACTS
 - 08 10 12 14 16 20 26
 - 30 34 40 50 60 64
- SERIES No. DS1014

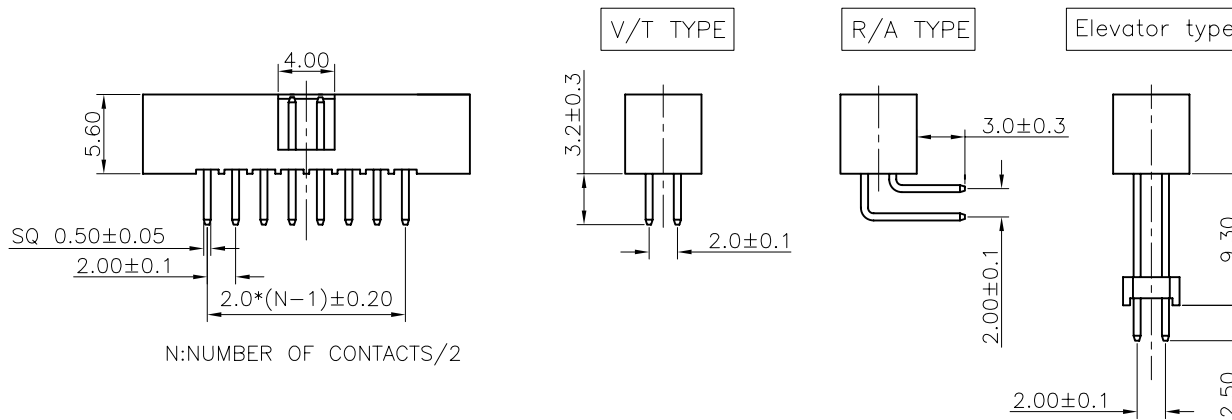
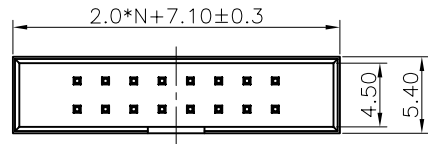

N:NUMBER OF CONTACTS/2

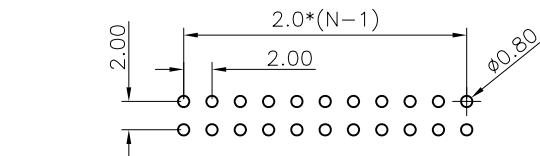

RECOMMEND PCB LAYOUT
(TOLERANCE=±0.05)

GENERAL TOLERANCE		ANGLE TOLERANCE		PROJECTION		TITLE	BOX HEADER PITCH 2.00mm	
X.	±0.60	X.	±5°	UNITS	mm			
.X	±0.38	.X	±3°	SHEET SIZE	A4	SERIES	DS1014 SERIES	
.XX	±0.25	.XX	±2°	晨翔电子有限公司 CONNPLY CONNPLY ELECTRONIC CO. LTD				
DRAWING TYPE		CUSTOMER						
SCALE	1:1	SHEET	1 OF 1					
DRAWING NO.		C-DS1014-XXXX						

REV.	DESCRIPTION	DRAWN	CHECKED	APPROVED
A	NEW RELEASE	YCH 09/11/23'	~	

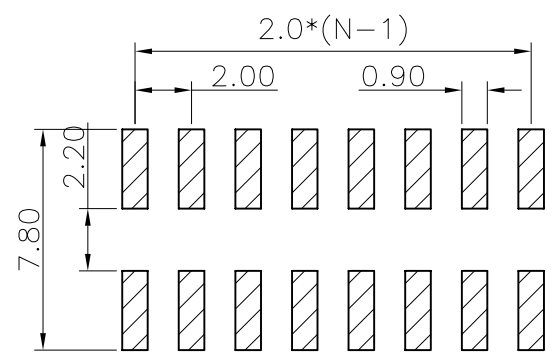
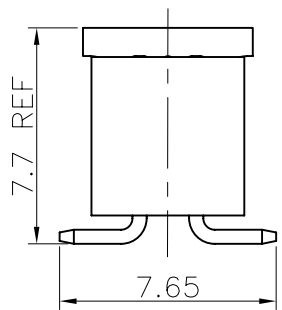
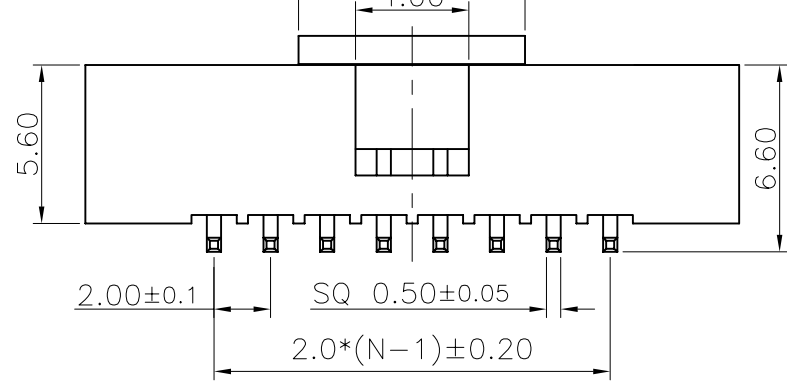
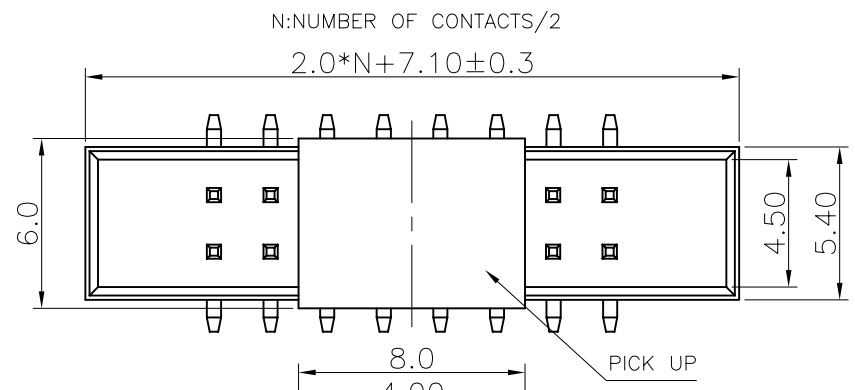

NOTES:

- MATERIAL
 - INSULATOR: THERMOPLASTIC (UL 94V-0).
 - CONTACT: COPPER ALLOY.
- SPECIFICATION
 - TEMPERATURE: -40°C ~ +105°C.
 - CONTACT RESISTANCE: 20mΩ max. (initial).
 - INSULATION RESISTANCE: 1000MΩ min.
 - DIELECTRIC WITHSTANDING VOLTAGE: AC 500V PER MINUTE.
- PART NUMBER: DS1014
- PRODUCT NUMBER CODE:

DS1014- X X X X X X

 - PACKING TYPE: T: TRAY, R: TAPE ON REEL, B: TUBE
 - PICK UP SUPPORT: S: W/ PICK UP, X: W/O PICK UP
 - HOUSING COLOR: B: BLACK, W: WHITE, L: BLUE, A: GRAY
 - CONTACT PLATING: F1: FULL GOLD FLASH
 - MOUNTING TYPE: M: SMT TYPE
 - No. OF CONTACTS: 08 10 12 14 16 20 26, 30 34 40 50 60 64
 - SERIES No.: DS1014

GENERAL TOLERANCE	ANGLE TOLERANCE	PROJECTION		TITLE	BOX HEADER PITCH 2.00mm SMT TYPE	
X. ±0.60	X. ±5°	UNITS	mm			
.X ±0.38	.X ±3°	SHEET SIZE	A4	SERIES	DS1014 SERIES	
.XX ±0.25	.XX ±2°	晨翔电子有限公司 CONNFLY ELECTRONIC CO. LTD				
DRAWING TYPE	CUSTOMER					
SCALE	1:1					SHEET
DRAWING NO.	C-DS1014-XMXXXX					

REV.	DESCRIPTION	DRAWN	CHECKED	APPROVED
A	NEW RELEASE	LJH 09/20/05'	~	LJC 09/20/05'
B	料号中增加尺寸DIM. H, E选项	YCH 07/18/08'	~	

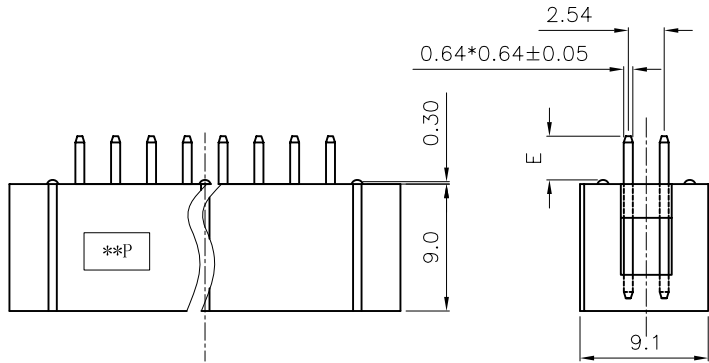
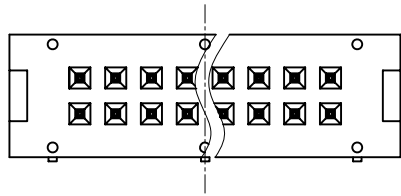

V/T TYPE

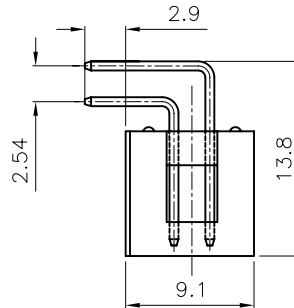

R/A TYPE

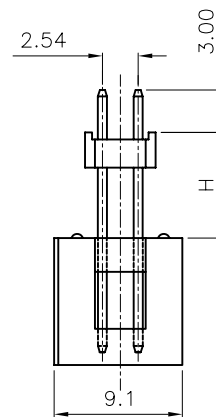

Elevator TYPE

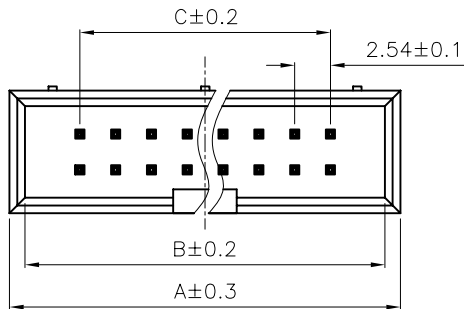

Dimension

Position	A	B	C				
10	20.30	18.10	10.16	30	45.70	43.50	35.56
12	22.84	20.64	12.70	34	50.78	48.58	40.64
14	25.38	23.18	15.24	40	58.40	56.20	48.26
16	27.92	25.72	17.78	50	71.10	68.90	60.96
20	33.00	30.80	22.86	60	83.80	81.60	73.66
26	40.62	38.42	30.48	64	88.88	86.68	78.74

NOTES:

- ELECTRICAL CHARACTERISTICS:
 - CONTACT RESISTANCE: 20mΩ Max. INITIAL.
 - DIELECTRIC WITHSTANDING VOLTAGE: 500V AC(rms) FOR 1 MINUTE.
 - INSULATION RESISTANCE: 1000MΩ Min.
- ENVIRONMENT CHARACTERISTICS:
 - TEMPERATURE RANGE: -45°C~+105°C.
- PART NUMBER: DS1013
- PRODUCT NUMBER CODE:
 DS1013- X X X X X X
 DIM. H TYPE (FOR ELEVATOR ONLY)
 1: 7.50
 2: 9.50
 DIM. E TYPE (FOR V/T ONLY)
 1: 3.10
 2: 8.00
 HOUSING COLOR
 B: BLACK
 W: WHITE
 U: BLUE
 A: GRAY
 CONTACT PLATING
 Si: FULL GOLD FLASH
 MOUNTING TYPE
 S: V/T TYPE
 R: R/A TYPE
 E: Elevator TYPE
 No.OF CONTACTS
 08 10 14 16 20
 24 26 30 34
 40 50 60 64

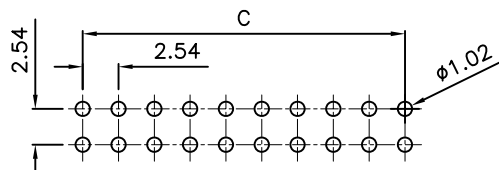

RECOMMEND PCB LAYOUT(TOLERANCE=±0.05)

GENERAL TOLERANCE		ANGLE TOLERANCE	
X.	±0.60	X.	±5°
.X	±0.38	.X	±3°
.XX	±0.25	.XX	±2°

PROJECTION	TITLE	BOX HEADER PITCH 2.54mm	
UNITS	mm		
SHEET SIZE	A4	SERIES	DS1013 SERIES

DRAWING TYPE	CUSTOMER		
SCALE	1:1	SHEET	1 OF 1
DRAWING NO.	C-DS1013-XXXX-B		

晨翔电子有限公司
CONNFLY CONNFLY ELECTRONIC CO. LTD

REV.	DESCRIPTION	DRAWN	CHECKED	APPROVED
A	NEW RELEASE	LJH 09/20/05'		

NOTES:

- ELECTRICAL CHARACTERISTICS:
 - CONTACT RESISTANCE: 20mΩ Max. INITIAL.
 - DIELECTRIC WITHSTANDING VOLTAGE: 500V AC(rms) FOR 1 MINUTE.
 - INSULATION RESISTANCE: 1000MΩ Min.
- ENVIRONMENT CHARACTERISTICS:
 - TEMPERATURE RANGE: -45°C~+105°C.
- PART NUMBER: DS1013
- PRODUCT NUMBER CODE:

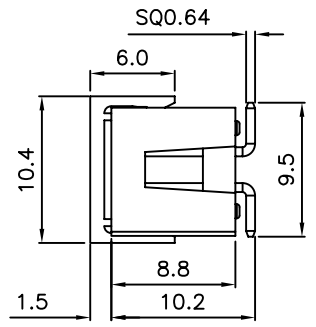
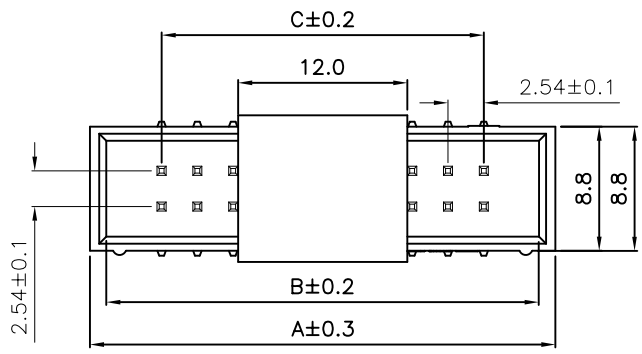

Dimension

Position	A	B	C
10	20.30	18.10	10.16
12	22.84	20.64	12.70
14	25.38	23.18	15.24
16	27.92	25.72	17.78
20	33.00	30.80	22.86
26	40.62	38.42	30.48
30	45.70	43.50	35.56
34	50.78	48.58	40.64
40	58.40	56.20	48.26
50	71.10	68.90	60.96
60	83.80	81.60	73.66
64	88.88	86.68	78.74

DS1013- X X X X

- PACKING TYPE
 - A: TUBE
 - R: TAPE ON REEL
 - T: TRAY
- PICK UP SUPPORT
 - S: W/ PICK UP
 - X: W/O PICK UP
- CONTACT PLATING
 - Si: FULL GOLD FLASH
- MOUNTING TYPE
 - M: SMT TYPE
- No.OF CONTACTS
 - 08 10 14 16 20
 - 24 26 30 34
 - 40 50 60 64
- SERIES No. DS1013

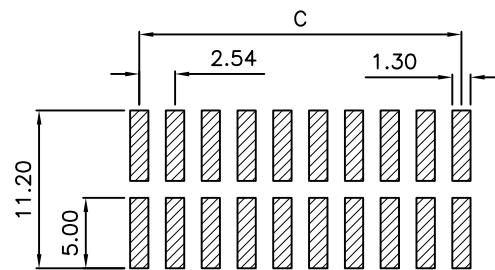
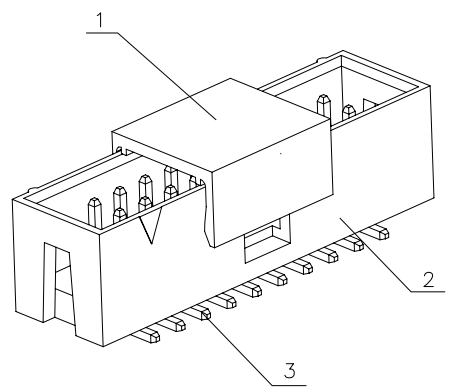
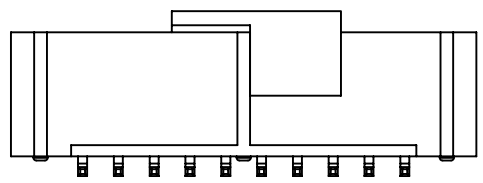

RECOMMEND PCB LAYOUT TOLERANCE=±0.05

GENERAL TOLERANCE		ANGLE TOLERANCE	
X.	±0.60	X.	±5°
.X	±0.38	.X	±3°
.XX	±0.25	.XX	±2°

PROJECTION		TITLE	BOX HEADER PITCH 2.54mm
UNITS	mm		SMT TYPE
SHEET SIZE	A4	SERIES	DS1013 SERIES

ITEM	PART NAME	PART NO.	MATERILAS	FINISHED
3	CONTACT		COPPER ALLOY	GOLD FLASH
2	HOUSING		NYLON-46	GLASS FILLED, UL 94 V-0
1	PICK UP		NYLON-46	UL 94 V-2

DRAWING TYPE	CUSTOMER
SCALE	1:1
SHEET	1 OF 1
DRAWING NO.	C-DS1013-XXMXXXX

晨翔电子有限公司
CONNFLY CONNFLY ELECTRONIC CO. LTD

REV.	DESCRIPTION	DRAWN	CHECKED	APPROVED
A	NEW RELEASE	YCH 12/18/09'	~	

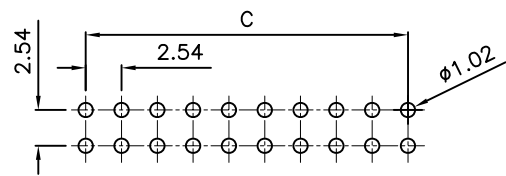
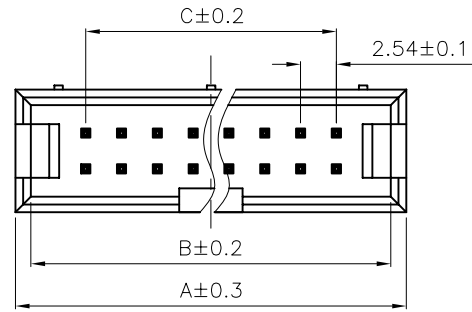
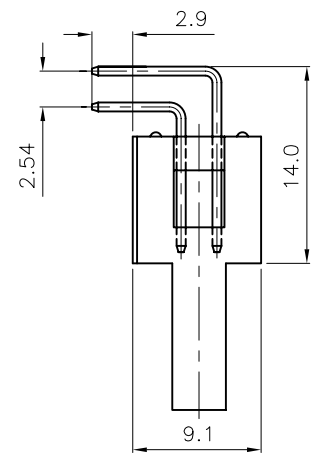
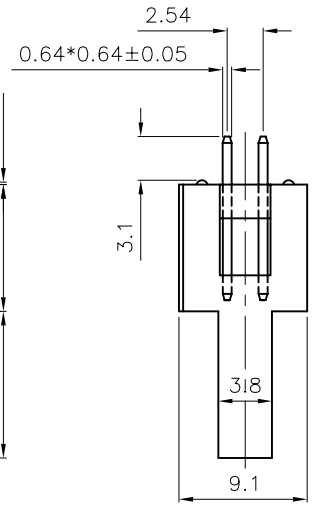
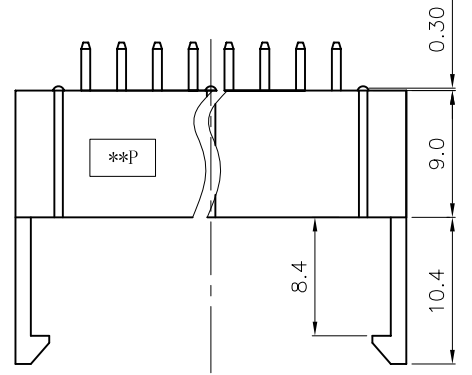
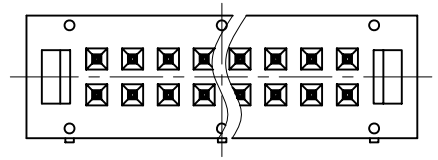

NOTES:

- ELECTRICAL CHARACTERISTICS:
 - CONTACT RESISTANCE: 20mΩ Max. INITIAL.
 - DIELECTRIC WITHSTANDING VOLTAGE: 500V AC(rms) FOR 1 MINUTE.
 - INSULATION RESISTANCE: 1000MΩ Min.
- ENVIRONMENT CHARACTERISTICS:
 - TEMPERATURE RANGE: -45°C~+105°C.
- PART NUMBER: DS1013-01
- PRODUCT NUMBER CODE: DS1013-01- X X X X

HOUSING COLOR
 B: BLACK
 W: WHITE
 U: BLUE
 A: GRAY

CONTACT PLATING
 Si: FULL GOLD FLASH

MOUNTING TYPE
 S: V/T TYPE
 R: R/A TYPE

No.OF CONTACTS
 06 08 10 14 16
 20 26 30 34
 40 50 60 64

Dimension

Position	A	B	C				
10	20.30	18.10	10.16	30	45.70	43.50	35.56
12	22.84	20.64	12.70	34	50.78	48.58	40.64
14	25.38	23.18	15.24	40	58.40	56.20	48.26
16	27.92	25.72	17.78	50	71.10	68.90	60.96
20	33.00	30.80	22.86	60	83.80	81.60	73.66
26	40.62	38.42	30.48	64	88.88	86.68	78.74

GENERAL TOLERANCE		ANGLE TOLERANCE	
X.	±0.60	X.	±5°
.X	±0.38	.X	±3°
.XX	±0.25	.XX	±2°

PROJECTION	TITLE	BOX HEADER PITCH 2.54mm WITH LATCH TYPE	
UNITS	mm	SHEET	DS1013-01 SERIES
SHEET SIZE	A4	SERIES DS1013-01 SERIES	

DRAWING TYPE	CUSTOMER		
SCALE	1:1	SHEET	1 OF 1
DRAWING NO.	C-DS1013-01-XXXX		

晨翔电子有限公司
CONNFLY CONNFLY ELECTRONIC CO. LTD

REV.	DESCRIPTION	DRAWN	CHECKED	APPROVED
A	NEW RELEASE	YCH 09/04/08'	~	

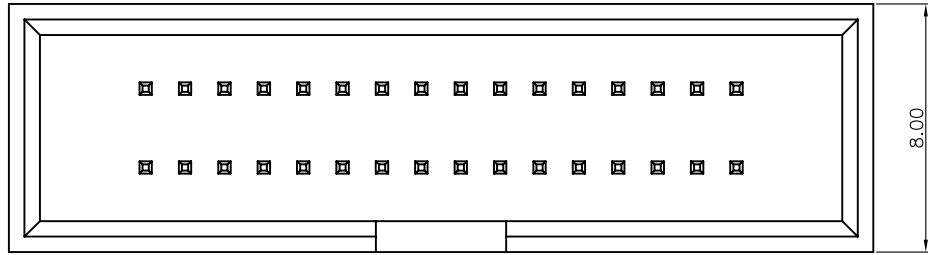

NOTES:

- MATERIAL
 - INSULATOR:THERMOPLASTIC(UL 94V-0).
 - CONTACT MATERIAL:COPPER ALLOY.
- SPECIFICATION
 - CURRENT RATING:1.0 Amp.
 - INSULATION RESISTANCE:1000MΩ Min.
 - DIELECTRIC WITHSTANDING:300VAC.
 - CONTACT RESISTANCE:20mΩ Max.
 - OPERATING TEMPERATURE:-40°C TO+105°C.

3. PART NUMBER: DS1031-16

4. PRODUCT NUMBER CODE:

DS1031-16 - X X X X

- HOUSING COLOR
B:BLACK
- CONTACT PLATING
8: FULL GOLD FLASH
6: FULL TIN
- MOUNTING TYPE
V: STRAIGHT TYPE
- No.OF CONTACTS
06 ~ 40

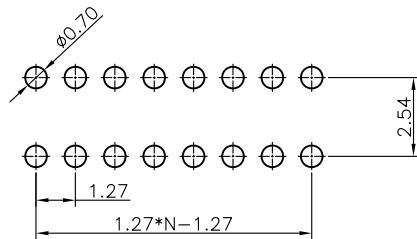
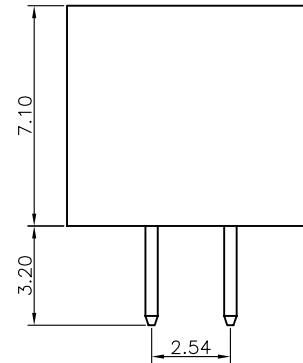
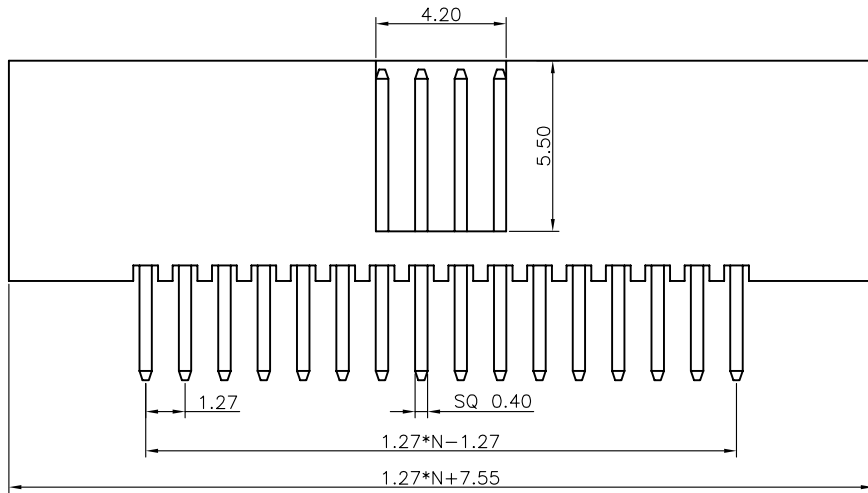

RECOMMEND PCB LAYOUT(TOLERANCE=±0.05)

GENERAL TOLERANCE		ANGLE TOLERANCE	
X.	±0.60	X.	±5°
.X	±0.38	.X	±3°
.XX	±0.25	.XX	±2°

DRAWING TYPE	CUSTOMER		
SCALE	1:1	SHEET	1 OF 1
DRAWING NO.	C-DS1031-16-XXXX		

PROJECTION	TITLE
UNITS	1.27*2.54mm BOX HEADER PITCH
SHEET SIZE	SERIES DS1031-16 SERIES

 晨翔电子有限公司
CONNFLY CONNFLY ELECTRONIC CO. LTD

REV.	DESCRIPTION	DRAWN	CHECKED	APPROVED
A	NEW RELEASE	YCH 09/04/08'	~	

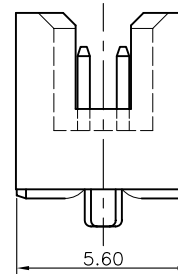
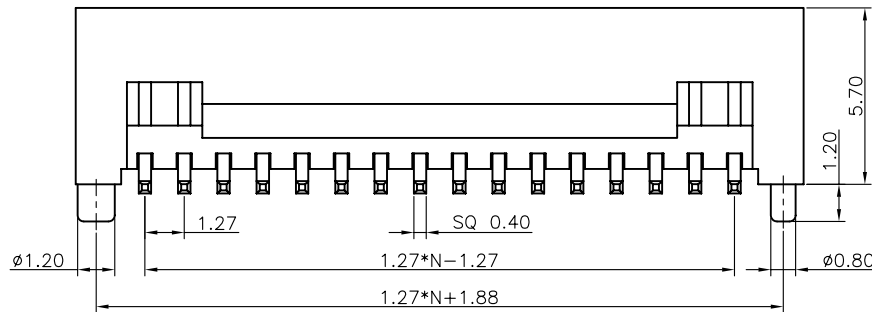
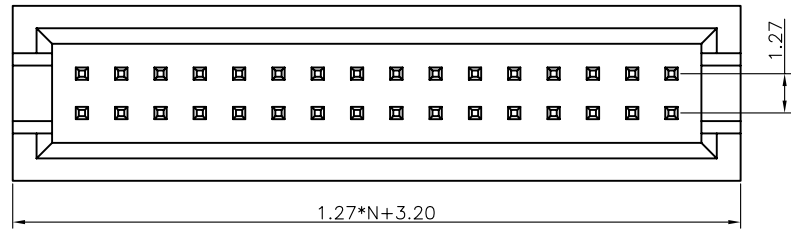

NOTES:

- MATERIAL
 - INSULATOR:THERMOPLASTIC(UL 94V-0).
 - CONTACT MATERIAL:COPPER ALLOY.
- SPECIFICATION
 - CURRENT RATING:1.0 Amp.
 - INSULATION RESISTANCE:1000MΩ Min.
 - DIELECTRIC WITHSTANDING:300VAC.
 - CONTACT RESISTANCE:20mΩ Max.
 - OPERATING TEMPERATURE:-40°C TO+105°C.

3. PART NUMBER: DS1031-14

4. PRODUCT NUMBER CODE:

DS1031-14 - X X X X

- HOUSING COLOR
B:BLACK
- CONTACT PLATING
8: FULL GOLD FLASH
6: FULL TIN
- MOUNTING TYPE
S:SMT TYPE
- No.OF CONTACTS
06 ~ 40

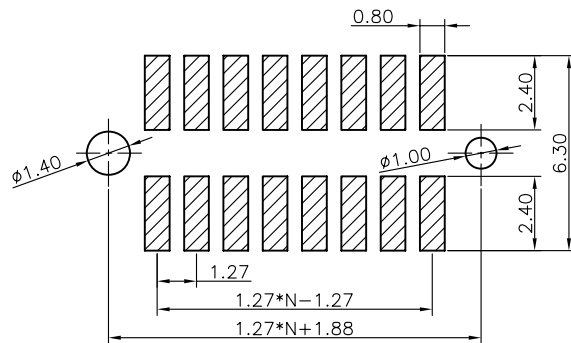

RECOMMEND PCB LAYOUT(TOLERANCE=±0.05)

GENERAL TOLERANCE		ANGLE TOLERANCE		PROJECTION		TITLE	1.27mm HEADER PITCH	
X.	±0.60	X.	±5°	UNITS	mm		SMT TYPE W/POST	
.X	±0.38	.X	±3°	SHEET SIZE	A4	SERIES	DS1031-14 SERIES	
.XX	±0.25	.XX	±2°	晨翔电子有限公司 CONNFLY CONNFLY ELECTRONIC CO. LTD				
DRAWING TYPE		CUSTOMER						
SCALE	1:1	SHEET	1 OF 1					
DRAWING NO.		C-DS1031-14-XXXXX						