

REV.	DESCRIPTION	DRAWN	CHECKED	APPROVED
A	NEW RELEASE	LJC 06/10/14'	~	

N:NUMBER OF CONTACTS/2
C/D:CUSTOMER LENGTH AVAILABLE

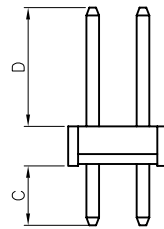
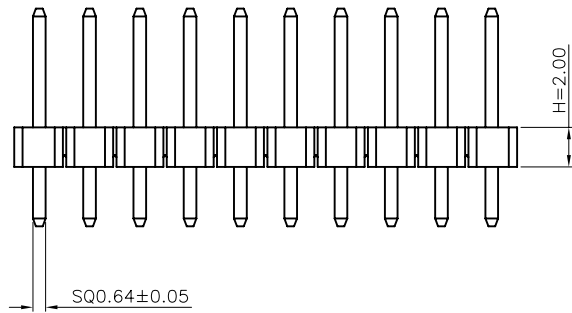
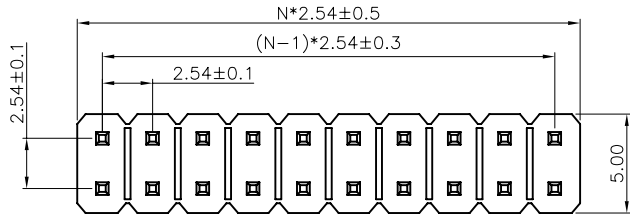

NOTES:

1. ELECTRICAL CHARACTERISTICS:

- 1.1 CONTACT RESISTANCE: 20mΩ Max.
- 1.2 DIELECTRIC WITHSTANDING VOLTAGE: 500V AC(rms) FOR 1 MINUTE.
- 1.3 INSULATION RESISTANCE: 1000MΩ Min.
- 1.4 CURRENT RATING: 3A Per Pin Max.
- 1.5 VOLTAGE RATING: 250V AC/DC.

2. ENVIRONMENT CHARACTERISTICS:

- 2.1 TEMPERATURE RANGE: -40°C~+105°C.

3. PRODUCT NUMBER CODE:

DS1021-09 - X X X X - X

TABLE B:

TYPE	Dimension	
	C	D
1	3.00	6.00
2	2.80	4.00

PLATING LEVEL(FOR GOLD ONLY)
B: LEVEL B

TABLE A & DIM. TYPE
1: TYPE 1
2: TYPE 2

⋮

CONTACT PLATING
F1: FULL GOLD FLASH

MOUNTING TYPE
S: STRAIGHT TYPE

No. OF CONTACTS
2*1~2*40

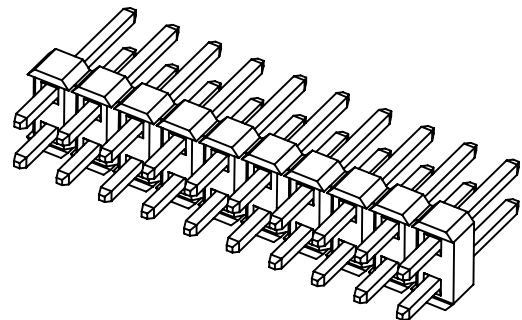

GENERAL TOLERANCE		ANGLE TOLERANCE		PROJECTION		TITLE	2.54mm PIN HEADER V/T TYPE	
X.	±0.60	X.	±5°	UNITS	mm	2 ROWS H=2.0mm		
.X	±0.38	.X	±3°	SHEET SIZE	A4	SERIES	DS1021-09 SERIES	
.XX	±0.25	.XX	±2°	晨翔电子有限公司 CONNFLY CONNFLY ELECTRONIC CO., LTD				
DRAWING TYPE		CUSTOMER						
SCALE		SHEET 1 OF 2						
DRAWING NO. C-DS1021-09-2*XXXX-X								

REV.	DESCRIPTION	DRAWN	CHECKED	APPROVED
A	NEW RELEASE	LL 07/03/06'	~	LJC 04/04/06'
F	ADD DIM	LL 11/16/06'	~	LJC 11/05/06'
H	ADD DIM	LL 11/29/06'	~	LJC 11/29/06'
J	ADD DIM	YCH 09/12/07'	~	LJC 09/24/07'
K	ADD DIM	YCH 09/12/07'	~	LJC 01/27/10'
L	ADD DIM	DGQ 03/18/11'	~	

SINGLE ROW
N:NUMBER OF CONTACTS
A/B:CUSTOMER LENGTH AVAILABLE

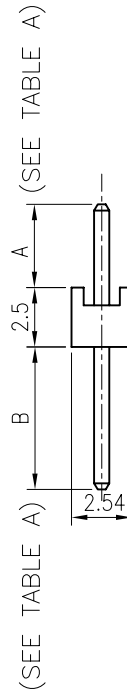
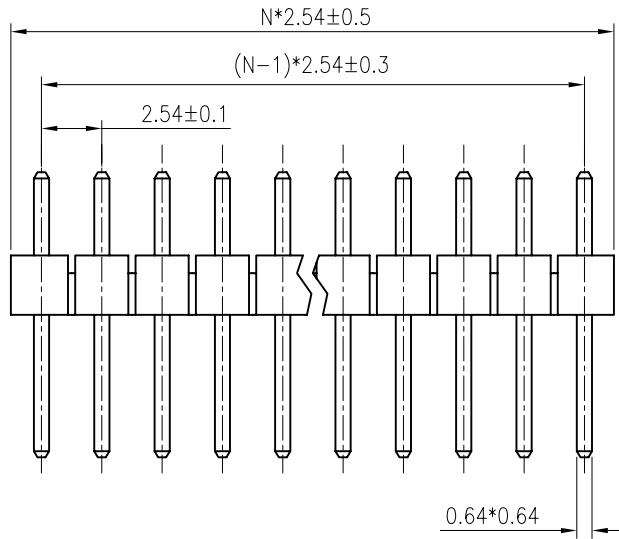

NOTES:

- ELECTRICAL CHARACTERISTICS:
 - CONTACT RESISTANCE: 20mΩ Max.
 - DIELECTRIC WITHSTANDING VOLTAGE: 500V AC(rms) FOR 1 MINUTE.
 - INSULATION RESISTANCE: 1000MΩ Min.
- ENVIRONMENT CHARACTERISTICS:
 - TEMPERATURE: -40°C~+105°C.
- PRODUCT NUMBER CODE:

DS1021- X X X X

TABLE A & DIM. TYPE
1: TYPE 1
2: TYPE 2
3: TYPE 3
4: TYPE 4
5: TYPE 5
6: TYPE 6
7: TYPE 7
8: TYPE 8
9: TYPE 9

CONTACT PLATING
F1: FULL GOLD FLASH
6: TIN

MOUNTING TYPE
S: Straight TYPE

No. OF CONTACTS
1*1~1*40

GENERAL TOLERANCE		ANGLE TOLERANCE		PROJECTION	TITLE	PIN HEADER PITCH 2.54mm V/T TYPE	
X.	±0.60	X.	±5°	⊕	mm		
.X	±0.38	.X	±3°		A4	SERIES	DS1021 SERIES
.XX	±0.25	.XX	±2°				
DRAWING TYPE	CUSTOMER			 晨翔电子有限公司 CONNFLY CONNFLY ELECTRONIC CO. LTD			
SCALE	~	SHEET	1 OF 2				
DRAWING NO.	C-DS1021-1*XXX						

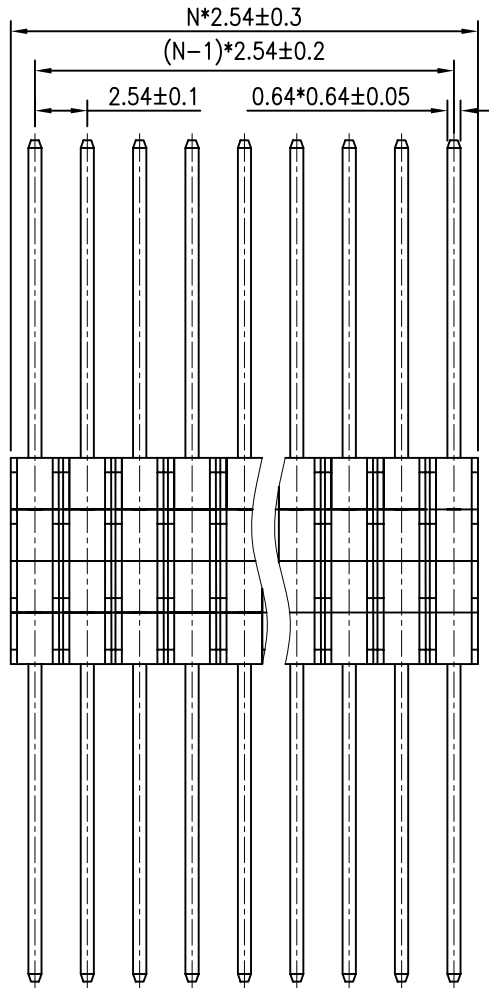

N=NUMBER OF CONTACTS

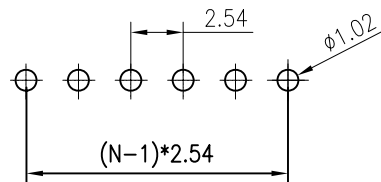

RECOMMEND PCB LAYOUT(TOLERANCE=±0.05)

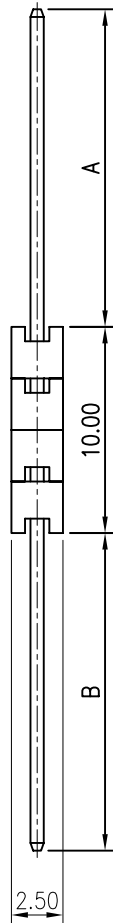

REV.	DESCRIPTION	DRAWN	CHECKED	APPROVED
A	NEW RELEASE	ych 11/05/08'		

NOTES:

- MATERIAL
 - INSULATOR:THERMOPLASTIC(UL94 V-0).
 - CONTACT MATERIAL:COPPER ALLOY.
- SPECIFICATION
 - CURRENT RATING:1.5 Amp.
 - INSULATION RESISTANCE:1000MΩ Min.
 - DIELECTRIC WITHSTANDING:600VAC.
 - CONTACT RESISTANCE:50mΩ Max.
 - OPERATING TEMPERATURE:-40°C TO+105°C.

3. PRODUCT NUMBER CODE:

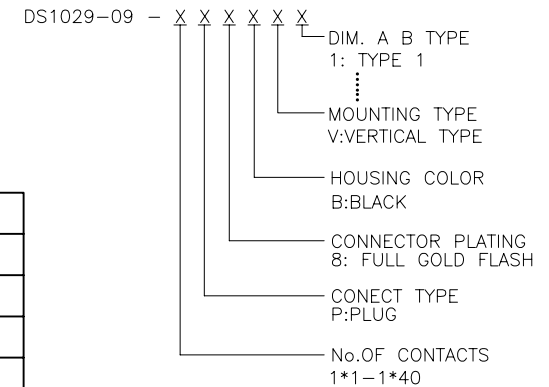

TYPE	A	B
1	15.40	15.40
2	15.90	15.90
3		
4		
5		
6		
7		
8		
9		
10		
11		

GENERAL TOLERANCE		ANGLE TOLERANCE		PROJECTION		TITLE	BOARD SPACERS PIN HEADER PITCH 2.54mm	
X.	±0.60	X.	±5°	UNITS	mm	SHEET	DS1029-09 SERIES	
.X	±0.38	.X	±3°	SHEET SIZE	A4			
.XX	±0.25	.XX	±2°					
DRAWING TYPE		CUSTOMER			晨翔电子有限公司 CONNFLY CONNFLY ELECTRONIC CO. LTD			
SCALE		1:1	SHEET 1 OF 1					
DRAWING NO.		C-DS1029-09-XXXXX						

REV.	DESCRIPTION	DRAWN	CHECKED	APPROVED
A	NEW RELEASE	LJH 11/29/05'	~	LJC 11/29/05'
B	ADD DIM.	LJH 04/20/06'	~	LJC 04/20/06'
C	ADD DIM.	LL 11/23/06'	~	LJC 11/23/06'
D	ADD DIM.	YCH 04/23/08'	~	LJC 04/23/08'
E	增加V1与V2选择	YCH 03/25/09'	~	

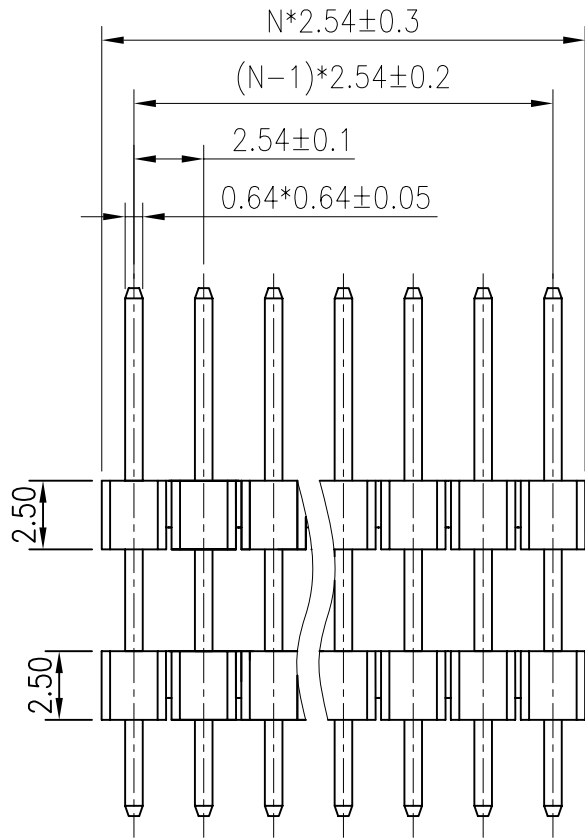

N:NUMBER OF CONTACTS

V1 TYPE V2 TYPE

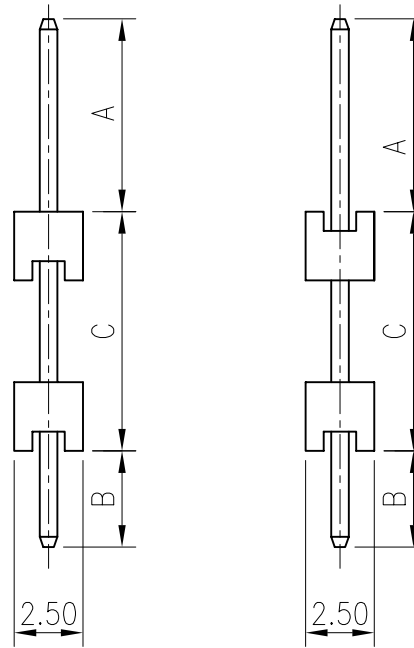

NOTES:

- MATERIAL
 - INSULATOR:THERMOPLASTIC(UL94 V-0).
 - CONTACT MATERIAL:COPPER ALLOY.
- SPECIFICATION
 - CURRENT RATING:1.5 Amp.
 - INSULATION RESISTANCE:1000MΩ Min.
 - DIELECTRIC WITHSTANDING:600VAC.
 - CONTACT RESISTANCE:50mΩ Max.
 - OPERATING TEMPERATURE:-40°C TO+105°C.
- PART NUMBER: DS1029-01
- PRODUCT NUMBER CODE:
 DS1029-01 - X X X X X X X
 DIM.A B C TYPE
 1: TYPE 1
 2: TYPE 2
 42: TYPE 42

 BEND TYPE
 A: V1 TYPE
 B: V2 TYPE
 MOUNTING TYPE
 V:VERTICAL TYPE
 HOUSING COLOR
 B:BLACK
 CONNECTOR PLATING
 8: FULL GOLD FLASH
 7: FULL 30U" GOLD
 6: FULL TIN
 CONECT TYPE
 P:PLUG
 No.OF CONTACTS
 1*1-1*40

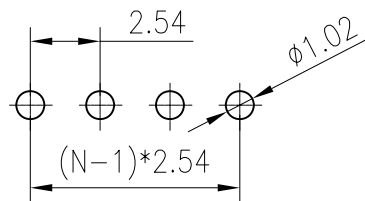

RECOMMEND PCB LAYOUT
(TOLERANCE=±0.05)

GENERAL TOLERANCE		ANGLE TOLERANCE		PROJECTION		TITLE	BOARD SPACERS PIN HEADER
X.	±0.60	X.	±5'	UNITS	mm		PITCH 2.54mm
.X	±0.38	.X	±3'	SHEET SIZE	A4	SERIES	DS1029-01 SERIES
.XX	±0.25	.XX	±2'	晨翔电子有限公司 CONNFLY CONNFLY ELECTRONIC CO. LTD			
DRAWING TYPE		CUSTOMER					
SCALE	1:1	SHEET	1 OF 2				
DRAWING NO.		C-DS1029-01-XXXXXXX					

A/B/C: CUSTOMER LENGTH AVAILABLE

TABLE A:

TYPE	Dimension		
	A	C	B
1	6.00	12.00	3.00
2	7.00	8.50	3.50
3	6.40	10.40	3.00
4	18.60	10.40	3.00
5	6.00	18.00	3.00
6	6.00	21.00	3.00
7	6.00	24.00	3.00
8	6.40	22.00	3.00
9	9.00	14.00	3.00
10	18.00	3.00	12.50
11	6.00	36.00	3.00
12	6.00	30.00	3.00
13	3.00	15.08	3.00
14	3.00	5.00	4.32
15	6.00	5.00	6.00
16	3.00	27.00	3.00
17	3.00	5.00	6.00
18	6.00	10.40	3.00
19	3.00	20.50	6.00
20	3.00	5.00	3.00
21	3.50	15.50	3.00
22	6.00	21.00	3.00
23	6.00	27.00	3.00

TYPE	Dimension		
	A	C	B
24	6.00	10.80	3.00
25	6.00	7.00	3.00
26	7.00	23.00	4.00
27	6.00	9.00	3.00
28	7.00	28.00	4.00
29	6.00	8.00	3.00
30	15.00	19.00	3.00
31	10.00	17.00	3.00
32	3.50	30.50	3.50
33	6.00	13.70	3.00
34	6.00	32.10	3.00
35	8.00	10.00	3.00
36	3.00	24.00	3.00
37	5.50	6.00	3.00
38	7.50	24.50	3.00
39	3.00	12.00	3.00
40	6.00	16.00	3.00
41	3.00	37.30	3.00
42	3.00	30.80	3.00
43	3.00	39.00	3.00
44	3.00	36.50	3.00
45	3.00	12.70	3.00
46	3.00	15.00	3.00

TYPE	Dimension		
	A	C	B
47	3.00	16.50	3.00
48	2.00	21.00	2.00
49	3.00	8.50	3.00
50	6.00	23.00	3.00
51	10.30	12.00	3.20
52	7.00	18.00	3.00
53	6.00	20.00	3.00
54	6.00	28.80	3.00
55	3.00	15.4	3.00
56	3.10	9.40	1.50
57	3.00	7.00	3.00
58	6.00	16.40	3.00
59	10.80	12.00	3.20
60	3.00	8.00	3.00
61	6.00	5.00	3.00
62	6.00	18.00	10.00
63	5.70	13.80	3.30
64	6.00	11.00	3.00
65	9.50	12.00	3.00
66			
67			
68			
69			

TYPE	Dimension		
	A	C	B
70			
71			
72			
73			
74			
75			
76			
77			
78			
79			
80			
81			
82			
83			
84			
85			
86			
87			
88			
89			
90			
91			
92			

TYPE	Dimension		
	A	C	B
93			
94			
95			
96			
97			
98			
99			
100			
101			
102			
103			
104			
105			
106			
107			
108			
109			
110			
111			
112			
113			
114			
115			

REV.	DESCRIPTION	DRAWN	CHECKED	APPROVED
A	NEW RELEASE	LJH 11/29/05'		LJC 11/29/05'
B	ADD DIM.	LJH 04/20/06'		LJC 04/20/06'
C	ADD DIM.	LL 11/23/06'		LJC 11/23/06'
D	ADD DIM.	YCH 04/23/08'		LJC 04/23/08'
E	增加V1与V2选择	YCH 03/25/06'		

DS1029-01

GENERAL TOLERANCE		ANGLE TOLERANCE		PROJECTION		TITLE	BOARD SPACERS PIN HEADER	
X.	±0.60	X.	±5'	UNITS	mm	PITCH 2.54mm		
.X	±0.38	.X	±3'	SHEET SIZE	A4	SERIES	DS1029-01 SERIES	
.XX	±0.25	.XX	±2'	晨翔电子有限公司 CONNFLY CONNFLY ELECTRONIC CO. LTD				
DRAWING TYPE		CUSTOMER						
SCALE	1:1	SHEET	2 OF 2					
DRAWING NO.		C-DS1029-01-XXXXXXX						

U TYPE

REV.	DESCRIPTION	DRAWN	CHECKED	APPROVED
A	NEW RELEASE	LJH 09/15/05'	~	LJC 09/15/05'
B,C,D	ADD DIM.	LJH 04/04/06'	~	LJC 04/04/06'
F	ADD DIM.	LJH 04/15/06'	~	LJC 04/04/06'
G	整理图面	YCH 03/15/07'	~	LJC 03/15/07'
K	整理图面	YCH 08/12/09'	~	

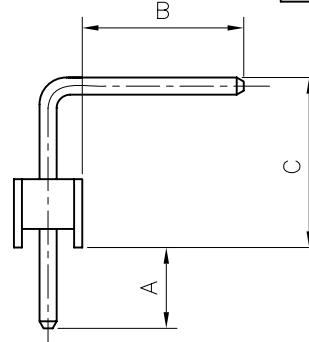
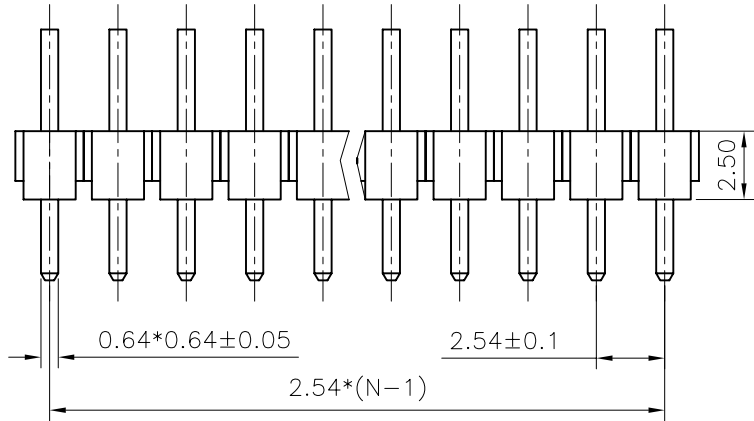

NOTES:

- MATERIALS
 - CONTACT MATERIAL: COPPER ALLOY.
 - INSULATOR: PBT OR PA-46
- SPECIFICATIONS
 - CURRENT RATING: 3A.
 - OPERATING TEMPERATURE: -40°C TO +105°C.
 - INSULATION RESISTANCE: 1000MΩ MIN.
 - CONTACT RESISTANCE: 20mΩ MAX.
 - DIELECTRIC WITHSTANDING: 600 VAC.
- PART NUMBER: DS1022
- PRODUCT NUMBER CODE:

DS1022- X X X X X

Dim. A B C type
 1: Type 1
 26: Type 26
 CONTACT PLATING
 F1: FULL GOLD FLASH
 6: FULL TIN
 BEND TYPE
 U:U TYPE
 MOUNTING TYPE
 R:R/A
 No.OF CONTACTS
 1*1 - 1*40

TABLE A:

TYPE	Dimension			Pin Length (mm)
	A	B	C	
1	3.00	6.00	6.07	15.50
2	4.00	6.90	3.40	14.70
3	6.00	11.40	5.64	23.40
4	3.75	3.40	3.40	11.00
5	2.80	4.00	3.40	10.60
6	5.85	7.90	3.40	17.50
7	3.60	3.20	3.40	10.60
8	6.30	3.20	4.36	14.20
9	3.00	6.00	5.42	15.00
10	3.64	5.76	6.48	16.30
11	3.00	6.00	5.00	14.40
12	3.10	3.40	3.40	10.50
13	6.00	4.90	3.40	14.70
14	6.30	3.00	3.40	14.00
15	6.20	3.70	3.60	14.00
16	3.00	6.30	4.20	14.00
17	2.30	5.11	5.30	13.10
18	6.20	3.80	3.40	13.80
19	4.70	4.70	4.20	14.00
20	4.00	6.93	5.50	16.85
21	2.50	5.40	4.50	12.80
22	5.10	3.50	4.00	13.10

普通

23	3.00	4.40	4.00	11.85
24	3.00	4.75	4.00	12.15
25	4.70	4.80	3.70	13.70
26	3.00	12.50	5.00	20.95
27	5.80	4.30	3.34	13.85
28	2.50	5.20	4.30	12.40
29	3.00	6.20	6.45	16.10
30	3.00	6.00	4.30	13.80
31	7.50	7.80	4.00	19.80
32	3.00	7.00	6.07	15.50
33	3.00	6.00	6.57	16.00
34	6.00	4.40	3.68	14.50
35	3.07	5.92	6.50	15.90
36	3.30	3.15	5.10	12.00
37	3.00	6.50	4.50	14.40
38	3.00	6.50	5.07	15.00
39	6.00	2.40	4.20	13.00
40	6.10	3.20	4.36	14.10
41	4.20	4.20	4.20	13.00
42	2.60	11.00	8.20	22.20

①

43	3.00	6.00	4.00	13.40
44	5.72	5.10	4.26	15.50
45	3.00	3.00	4.00	10.50
46				
47				
48				
49				
50				
51				
52				
53				
54				

N: NUMBER OF CONTACTS
 2.54*N REF

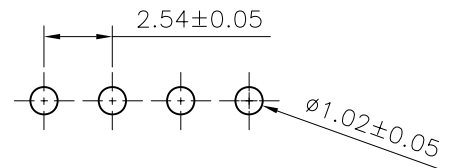
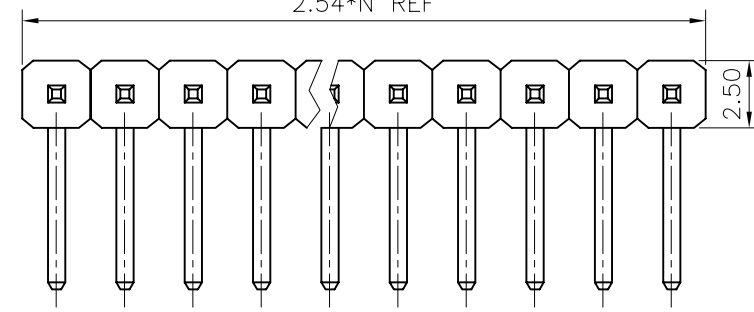

RECOMMEND P.C.BOARD LAYOUT

GENERAL TOLERANCE	ANGLE TOLERANCE	PROJECTION	TITLE
X. ±0.60	X. ±5°	mm	PIN HEADER PITCH 2.54mm R/A TYPE
.X ±0.38	.X ±3°	A4	SERIES DS1022 SERIES
.XX ±0.25	.XX ±2°		
DRAWING TYPE	CUSTOMER	晨翔电子有限公司 CONNFLY CONNFLY ELECTRONIC CO. LTD	
SCALE	1:1 SHEET 1 OF 1		
DRAWING NO.	C-DS1022-1*XXXUX		

D TYPE

REV.	DESCRIPTION	DRAWN	CHECKED	APPROVED
A	NEW RELEASE	LJH 04/06/06'	~	LJC 04/06/06'
B	ADD DIM	LL 08/05/06'	~	LJC 04/06/06'
C	增加规格整理图面	YCH 03/15/07'	~	LJC 03/15/07'
J	整理料号	YCH 04/23/08'	~	

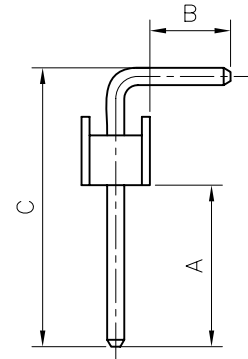
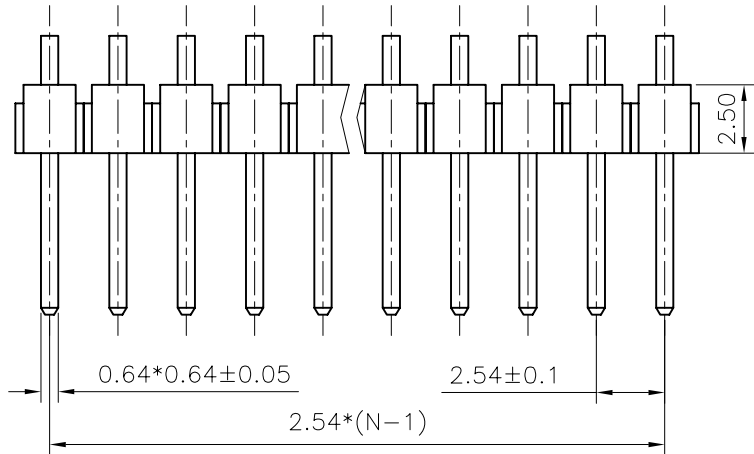

- NOTES:
- MATERIALS
 - 1.1 CONTACT MATERIAL: COPPER ALLOY.
 - 1.2 INSULATOR:PBT OR PA-46
 - SPECIFICATIONS
 - 2.1 CURRENT RATING: 3A.
 - 2.2 OPERATING TEMPERATURE: -40°C TO +105°C.
 - 2.3 INSULATION RESISTANCE: 1000MΩ MIN.
 - 2.4 CONTACT RESISTANCE: 20mΩ MAX.
 - 2.5 DIELECTRIC WITHSTANDING: 600 VAC.
 - PART NUMBER: DS1022
 - PRODUCT NUMBER CODE:

DS1022- X X D X X

- Dim. A B C type
- 1: Type 1
- 22: Type 22
-
- CONTACT PLATING
- F1: FULL GOLD FLASH
- 6: FULL TIN
- BEND TYPE
- D:D TYPE
- MOUNTING TYPE
- R:R/A
- No.OF CONTACTS
- 1*1 - 1*40

TABLE A:

TYPE	Dimension			Pin Length (mm)
	A	B	C	
1	6.00	3.00	10.36	13.80
2	6.00	4.50	9.50	14.40
3	6.10	4.00	10.40	14.80
4	6.00	3.20	10.50	14.10
5	6.00	3.50	10.82	14.70
6	4.70	1.73	8.20	10.40
7	15.00	3.00	19.08	22.50
8	6.00	3.10	11.10	14.40
9	1.00	1.91	5.00	7.40
10	6.20	3.20	11.10	14.70
11	6.20	3.20	10.8	14.40
12	4.50	2.93	8.00	11.40
13	6.30	2.60	10.36	13.40
14	5.70	2.95	9.52	12.90
15	4.80	3.00	8.10	11.50
16	6.00	3.00	9.14	12.60
17	7.20	3.00	10.36	13.80
18	3.00	6.00	7.50	13.80
19	3.00	6.00	9.32	15.80
20	3.50	3.00	7.86	11.30

普通

21	5.00	2.70	8.14	11.30
22	8.20	2.80	12.30	15.50
23	3.00	3.00	7.36	10.80
24	6.50	3.00	10.36	13.80
25	6.80	8.40	10.64	19.50
26	10.00	3.20	14.40	18.00
27	3.50	2.50	7.82	10.80
28	6.00	3.00	9.50	12.90
29	7.00	3.10	13.90	17.50
30	4.00	3.00	8.36	11.80
31	3.00	5.40	8.65	14.50
32	4.50	4.50	8.82	17.80
33	3.20	6.00	7.50	14.00
34				
35				
36				
37				
38				

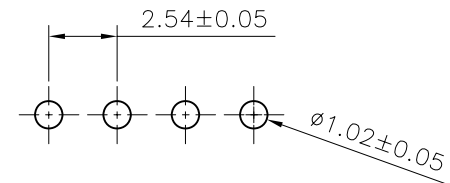
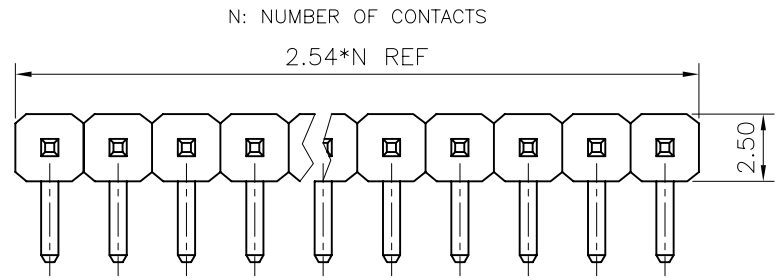

RECOMMEND P.C.BOARD LAYOUT

A/B/C: CUSTOMER LENGTH AVAILABLE

GENERAL TOLERANCE		ANGLE TOLERANCE		PROJECTION		TITLE	PIN HEADER PITCH 2.54mm R/A TYPE	
X.	±0.60	X.	±5°	UNITS	mm			
.X	±0.38	.X	±3°	SHEET SIZE	A4	SERIES	DS1022 SERIES	
.XX	±0.25	.XX	±2°					
DRAWING TYPE		CUSTOMER						
SCALE		1:1	SHEET		1 OF 1			
DRAWING NO.		C-DS1022-1*XXXXX						

晨翔电子有限公司
CONNFLY CONNFLY ELECTRONIC CO. LTD

REV.	DESCRIPTION	DRAWN	CHECKED	APPROVED
A	NEW RELEASE	YCH 05/19/08'	~	

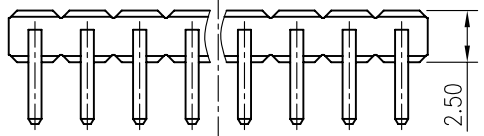
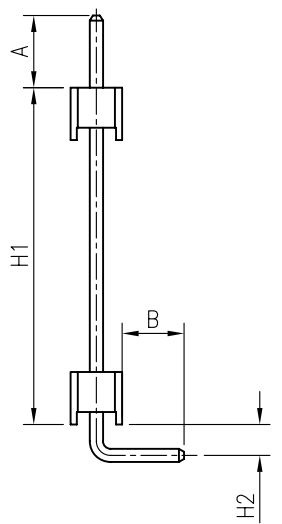
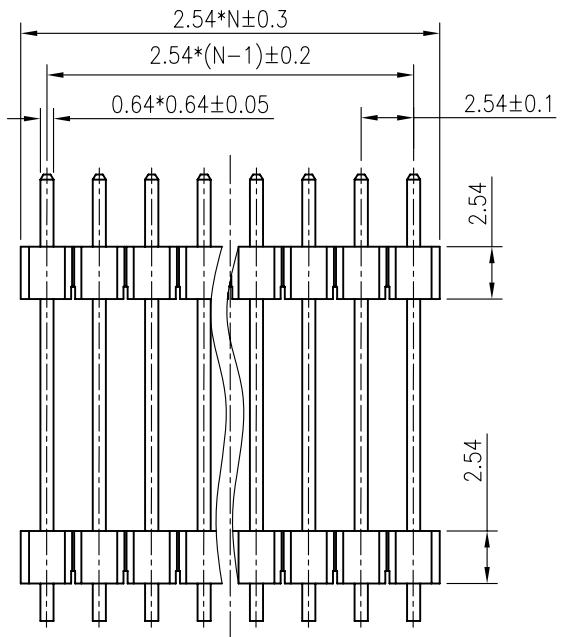

N: NUMBER OF CONTACTS

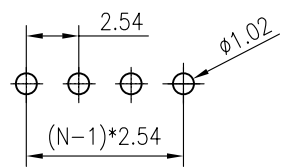

RECOMMEND PCB LAYOUT(TOLERANCE=±0.05)

NOTES:

- MATERIAL
 - INSULATOR:THERMOPLASTIC(UL94 V-0).
 - CONTACT MATERIAL:COPPER ALLOY.
- SPECIFICATION
 - CURRENT RATING:1.5 Amp.
 - INSULATION RESISTANCE:1000MΩ Min.
 - DIELECTRIC WITHSTANDING:600VAC.
 - CONTACT RESISTANCE:50mΩ Max.
 - OPERATING TEMPERATURE:-40°C TO+105°C.
- PART NUMBER: DS1029-02
- PRODUCT NUMBER CODE:
 DS1029-02 - X X X X X X
 DIM.A B H1 H2 YPE
 1: TYPE 1
 2: TYPE 2
 MOUNTING TYPE
 R: RIGHT ANGLE TYPE
 HOUSING COLOR
 B:BLACK
 CONNECTOR PLATING
 8: FULL GOLD FLASH
 CONECT TYPE
 P: PLUG
 No.OF CONTACTS
 1*1-1*40
 SERIES No.
 DS1029-02

TYPE	DIM A	DIM B	DIMH1	DIM H2	PIN LENGTH
1	3.50	3.00	16.33	1.50	25.10
2	3.50	3.00	6.33	1.50	15.10
3					
4					
5					
6					
7					
8					
9					
10					
11					
12					

GENERAL TOLERANCE		ANGLE TOLERANCE		PROJECTION		TITLE	2.54mm PITCH PIN HEADER SINGLE ROW RIGHT ANGLE	
X.	±0.60	X.	±5°	UNITS	mm			
.X	±0.38	.X	±3°	SHEET SIZE	A4	SERIES	DS1029-02 SERIES	
.XX	±0.25	.XX	±2°	晨翔电子有限公司 CONNFLY CONNFLY ELECTRONIC CO. LTD				
DRAWING TYPE		CUSTOMER						
SCALE	1:1	SHEET	1 OF 1					
DRAWING NO.		C-DS1029-02-XXXXXX						

REV.	DESCRIPTION	DRAWN	CHECKED	APPROVED
A	NEW RELEASE	LL 12/20/06'		

SINGLE ROW
 N:NUMBER OF CONTACTS
 A/B:CUSTOMER LENGTH AVAILABLE

- NOTES:
- MATERIAL
 - INSULATOR:THERMOPLASTIC(UL94 V-0).
 - CONTACT MATERIAL:COPPER ALLOY.
 - SPECIFICATION
 - CURRENT RATING:1.5 Amp.
 - INSULATION RESISTANCE:1000MΩ Min.
 - DIELECTRIC WITHSTANDING:600VAC.
 - CONTACT RESISTANCE:50mΩ Max.
 - OPERATING TEMPERATURE:-40°C TO+105°C.

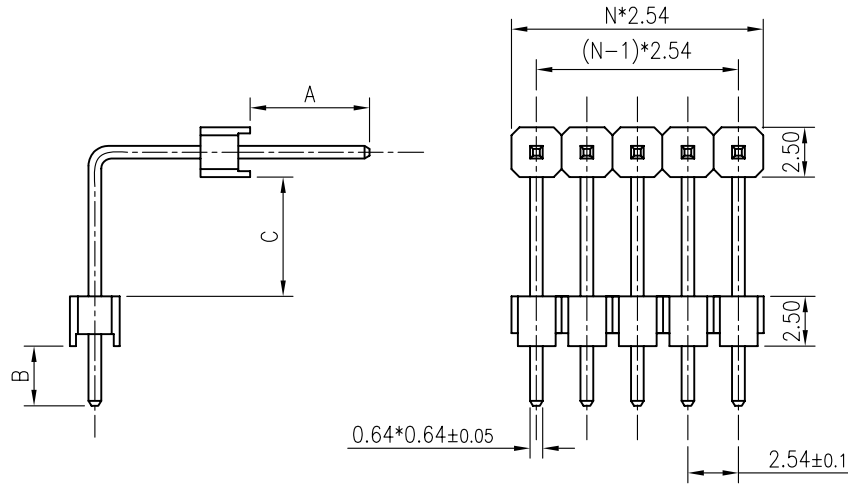

3. PRODUCT NUMBER CODE:
 DS1029-07 - X X X X X X
 DIM.A B YPE
 1: TYPE 1
 MOUNTING TYPE
 R: RIGHT ANGLE TYPE
 HOUSING COLOR
 B:BLACK
 CONNECTOR PLATING
 8: FULL GOLD FLASH
 CONECT TYPE
 P:PLUG
 No.OF CONTACTS
 1*1-1*40

TABLE A

TYPE	Dimension			Pin Length (mm)
	A	B	C	
1	6.00	3.00	6.00	26.00
2				
3				
4				
5				
6				
7				
8				
9				
10				
11				
12				
13				

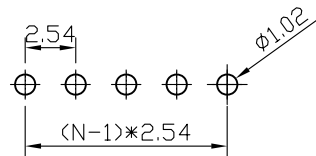

RECOMMEND PCB LAYOUT(TOLERANCE=±0.05)

GENERAL TOLERANCE		ANGLE TOLERANCE		PROJECTION		TITLE	2.54mm PITCH PIN HEADER RIGHT ANGLE				
X.	±0.60	X.	±5'	UNITS	mm	SHEET SIZE	A4	SERIES	DS1029-07 SERIES		
.X	±0.38	.X	±3'								
.XX	±0.25	.XX	±2'								
DRAWING TYPE		CUSTOMER			晨翔电子有限公司 CONNFLY CONNFLY ELECTRONIC CO. LTD						
SCALE		1:1	SHEET							1 OF 1	
DRAWING NO.		C-DS1029-07-XXXXXX									

REV.	DESCRIPTION	DRAWN	CHECKED	APPROVED
A	NEW RELEASE	LL 07/03/06'	~	LJC 04/04/06'
F	ADD DIM	LL 11/05/06'	~	LJC 11/05/06'
H	ADD DIM	LL 11/16/06'	~	LJC 11/16/06'
J	ADD DIM	YCH 09/12/07'	~	LJC 09/12/07'
K	ADD DIM	LBG 01/27/10'	~	LJC 01/27/10'

DUAL ROWS
 N:NUMBER OF CONTACTS/2
 C/D:CUSTOMER LENGTH AVAILABLE

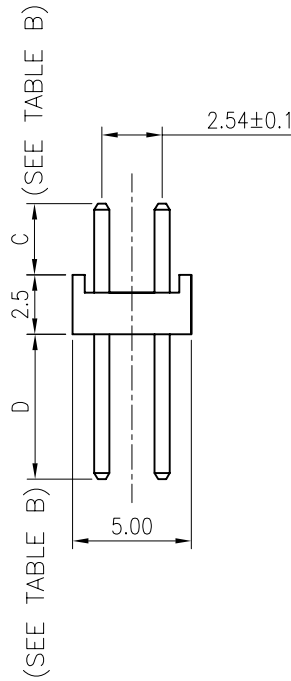
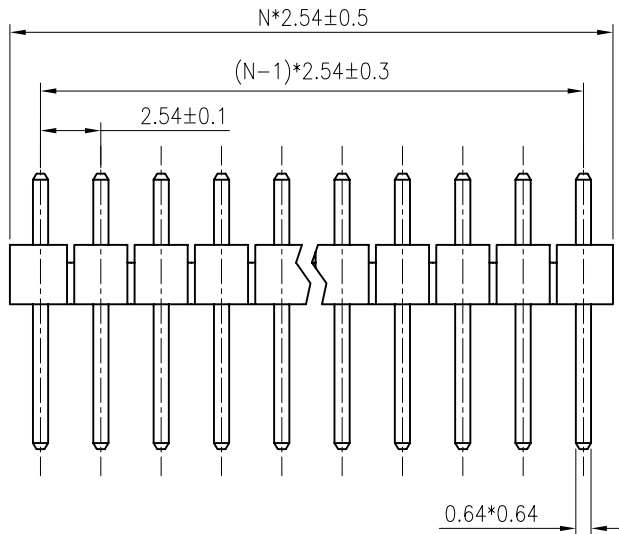

NOTES:

- ELECTRICAL CHARACTERISTICS:
 - CONTACT RESISTANCE: 20mΩ Max.
 - DIELECTRIC WITHSTANDING VOLTAGE: 500V AC(rms) FOR 1 MINUTE.
 - INSULATION RESISTANCE: 1000MΩ Min.
- ENVIRONMENT CHARACTERISTICS:
 - TEMPERATURE: $-40^{\circ}\text{C} \sim +105^{\circ}\text{C}$.
- PRODUCT NUMBER CODE:

DS1021- X X X X

TABLE B & DIM. TYPE
 1: TYPE 1
 2: TYPE 2
 3: TYPE 3
 4: TYPE 4
 5: TYPE 5
 6: TYPE 6
 7: TYPE 7
 8: TYPE 8
 9: TYPE 9

CONTACT PLATING
 F1: FULL GOLD FLASH
 6: TIN

MOUNTING TYPE
 S: Straight TYPE

No. OF CONTACTS
 2*1~2*40

GENERAL TOLERANCE		ANGLE TOLERANCE		PROJECTION		TITLE	PIN HEADER PITCH 2.54mm V/T TYPE	
X.	±0.60	X.	±5'	UNITS	mm			
.X	±0.38	.X	±3'	SHEET SIZE	A4	SERIES	DS1021 SERIES	
.XX	±0.25	.XX	±2'	晨翔电子有限公司 CONNFLY CONNFLY ELECTRONIC CO. LTD				
DRAWING TYPE		CUSTOMER						
SCALE		SHEET 1 OF 2						
DRAWING NO.		C-DS1021-2*XXX						

REV.	DESCRIPTION	DRAWN	CHECKED	APPROVED
A	NEW RELEASE	LJH 09/22/05'	~	LJC 09/22/05'
B	ADD DIM.	LL 10/30/06'	~	LJC 10/30/06'
C	ADD DIM.	YCH 04/23/08'	~	LJC 04/23/08'
D	增加V1与V2选择	YCH 03/25/09'	~	

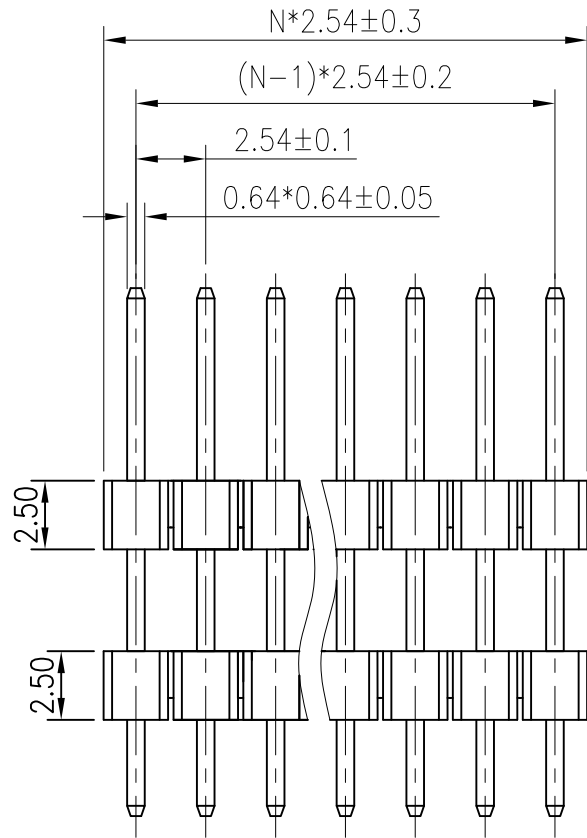

N:NUMBER OF CONTACTS

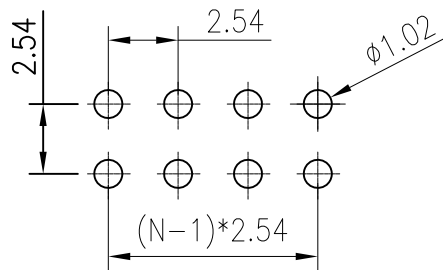

RECOMMEND PCB LAYOUT
(TOLERANCE=±0.05)

V1 TYPE V2 TYPE

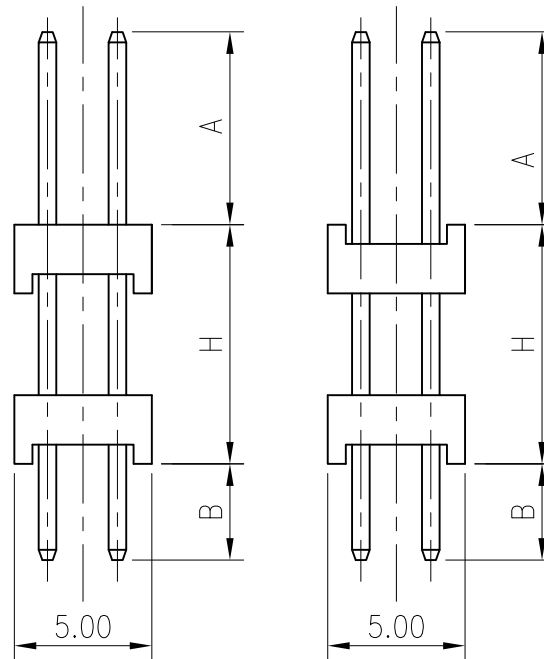

NOTES:

- SPECIFICATION
 - CURRENT RATING:1.5 Amp.
 - INSULATION RESISTANCE:1000MΩ Min.
 - DIELECTRIC WITHSTANDING:600VAC.
 - CONTACT RESISTANCE:50mΩ Max.
 - TEMPERATURE RANGE:-40°C TO+105°C.
- PART NUMBER: DS1029-04
- PRODUCT NUMBER CODE:

DS1029-04 - X X X X X X X

- DIM.A H B TYPE
 - 1: TYPE 1
 - 2: TYPE 2
 - 46: TYPE 46
 -
- BEND TYPE
 - A: V1 TYPE
 - B: V2 TYPE
- MOUNTING TYPE
 - V:VERTICAL TYPE
- HOUSING COLOR
 - B:BLACK
- CONNECTOR PLATING
 - 8: FULL GOLD FLASH
- CONECT TYPE
 - P:PLUG
- No.OF CONTACTS
 - 2*1-2*40

GENERAL TOLERANCE		ANGLE TOLERANCE		PROJECTION		TITLE	BOARD SPACERS PIN HEADER
X.	±0.60	X.	±5'	UNITS	mm		PITCH 2.54mm TYPE
.X	±0.38	.X	±3'	SHEET SIZE	A4	SERIES	DS1029-04 SERIES
.XX	±0.25	.XX	±2'	晨翔电子有限公司 CONNFLY CONNFLY ELECTRONIC CO. LTD			
DRAWING TYPE		CUSTOMER					
SCALE	1:1	SHEET	1 OF 2				
DRAWING NO.		C-DS1029-04-XXXXXXX					

A/B/C: CUSTOMER LENGTH AVAILABLE

REV.	DESCRIPTION	DRAWN	CHECKED	APPROVED
A	NEW RELEASE	LJH 09/22/05'		LJH 09/22/05'
E	ADD DIM	LL 10/30/06'		LJC 10/30/06'
F	ADD DIM	YCH 04/23/08'		LJC 04/23/08'
G	增加V1与V2选择	YCH 03/25/09'		

TABLE A:

TYPE	Dimension		
	A	H	B
1	18.60	10.40	3.00
2	5.80	14.85	2.85
3	6.00	15.00	3.00
4	10.40	12.60	3.50
5	6.40	10.40	3.00
6	6.00	20.50	3.00
7	6.50	11.50	3.00
8	6.50	6.50	3.00
9	10.80	12.60	3.50
10	6.00	10.40	3.00
11	6.50	6.50	3.00
12	9.00	14.00	3.00
13	4.40	5.00	3.00
14	10.00	10.00	3.00
15	6.00	5.08	3.00
16	6.50	22.10	3.30
17	6.40	11.30	3.30
18	6.00	26.00	3.00
19	6.00	11.50	3.00
20	3.50	7.00	3.50
21	6.00	6.50	3.00
22	6.00	21.50	3.00
23	10.00	15.00	3.00
24	7.00	11.00	7.00
25	13.00	12.00	3.30
26	10.80	12.60	3.00

TYPE	Dimension		
	A	H	B
27	6.00	12.00	3.00
28	7.30	15.60	7.10
29	12.30	15.60	7.10
30	5.00	32.00	3.00
31	6.00	9.00	3.00
32	6.00	22.40	3.00
33	6.00	27.00	3.00
34	6.00	36.00	3.00
35	6.00	11.00	3.00
36	3.00	18.00	6.00
37	6.00	7.00	3.00
38	6.00	8.00	3.00
39	6.20	25.60	3.20
40	6.00	21.00	3.00
41	6.00	28.00	3.00
42	6.00	7.00	3.00
43	6.00	17.00	3.00
44	6.00	16.00	3.00
45	5.50	6.00	3.00
46	5.00	17.00	3.00
47	6.00	6.70	3.30
48	11.00	15.00	3.00
49	2.60	37.40	6.00
50	6.00	24.00	3.00
51	5.84	20.62	3.00
52	6.00	23.00	3.00

TYPE	Dimension		
	A	H	B
53	6.00	10.00	3.00
54	3.00	26.00	3.00
55	10.50	9.50	3.50
56	12.00	38.00	4.00
57	8.00	14.40	3.60
58	8.70	9.80	3.50
59	7.00	43.00	4.00
60	3.00	34.00	8.50
61	9.50	12.30	3.50
62	8.20	10.80	3.50
63	6.00	30.00	3.00
64	10.00	12.00	3.00
65	8.50	9.00	3.00
66	6.00	11.00	3.50
67	12.70	11.00	2.80
68	6.00	5.00	3.00
69	13.00	7.50	3.60
70	6.00	20.00	3.00
71	3.00	10.40	3.00
72	6.00	13.50	3.00
73	3.50	27.70	10.50
74	6.00	31.50	3.30
75	3.00	16.50	3.00
76	4.00	15.00	3.00
77	6.50	15.50	3.00
78	11.30	22.50	2.50

TYPE	Dimension		
	A	H	B
79	17.50	13.00	3.50
80	8.00	14.00	8.00
81	6.00	41.00	3.00
82	5.84	13.16	3.00
83	6.00	39.00	3.00
84	6.50	13.00	3.50
85			
86			
87			
88			
89			
90			
91			
92			
93			
94			
95			
96			
97			
98			
99			
100			
101			
102			
103			
104			

TYPE	Dimension		
	A	H	B
105			
106			
107			
108			
109			
110			
111			
112			
113			
114			
115			
116			
117			
118			
119			
120			
121			
122			
123			
124			
125			
126			
127			
128			
129			
130			

DS1029-04

GENERAL TOLERANCE		ANGLE TOLERANCE		PROJECTION		TITLE	BOARD SPACERS PIN HEADER PITCH 2.54mm TYPE
X.	±0.60	X.	±5'	UNITS	mm		
.X	±0.38	.X	±3'	SHEET SIZE	A4	SERIES	DS1029-04 SERIES
.XX	±0.25	.XX	±2'	晨翔电子有限公司 CONFLY CONFLY ELECTRONIC CO. LTD			
DRAWING TYPE		CUSTOMER					
SCALE	1:1	SHEET	2 OF 2				
DRAWING NO.		C-DS1029-04-XXXXXXX					

REV.	DESCRIPTION	DRAWN	CHECKED	APPROVED
A	NEW RELEASE	LJC 01/15/09'		

SINGLE ROW
 N:NUMBER OF CONTACTS
 A/B:CUSTOMER LENGTH AVAILABLE

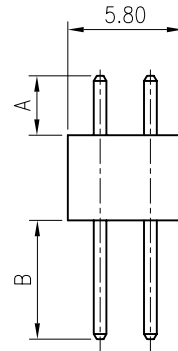
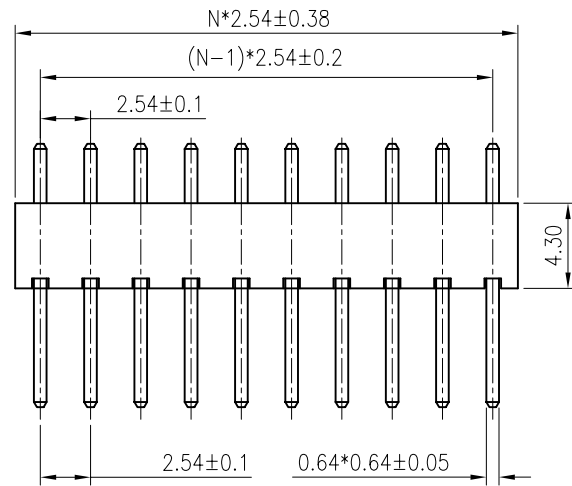

NOTES:

- ELECTRICAL CHARACTERISTICS:
 - CONTACT RESISTANCE: 20mΩ Max.
 - DIELECTRIC WITHSTANDING VOLTAGE: 500V AC(rms) FOR 1 MINUTE.
 - INSULATION RESISTANCE: 1000MΩ Min.
- ENVIRONMENT CHARACTERISTICS:
 - TEMPERATURE RANGE: -40°C~+105°C.

TABLE A:

TYPE	Dimension	
	A	B
1	3.00	6.00
2		
3		
4		
5		
6		
7		
8		
9		
10		
11		
12		
13		
14		
15		
16		
17		

3. PRODUCT NUMBER CODE:

DS1021-01- X X X X

DIM A & B TYPE
 1: TYPE 1

 CONTACT PLATING
 8: FULL GOLD FLASH
 6: TIN
 MOUNTING TYPE
 V: V/T TYPE
 No. OF CONTACTS
 2*2~2*40
 1*1~1*40

GENERAL TOLERANCE		ANGLE TOLERANCE		PROJECTION		TITLE	PIN HEADER PITCH 2.54mm
X.	±0.60	X.	±5'	UNITS	mm	V/T TYPE H=4.3mm	
.X	±0.38	.X	±3'	SHEET SIZE	A4	SERIES	DS1021-01 SERIES
.XX	±0.25	.XX	±2'	晨翔电子有限公司 CONNFLY CONNFLY ELECTRONIC CO. LTD			
DRAWING TYPE		CUSTOMER					
SCALE	1:1	SHEET	1 OF 1				
DRAWING NO.		C-DS1021-01-XXXXX					

REV.	DESCRIPTION	DRAWN	CHECKED	APPROVED
A	NEW RELEASE	YCH 03/15/08'	~	

NOTES:

- MATERIAL
 - INSULATOR:THERMOPLASTIC(UL 94V-0).
 - CONTACT: COPPER ALLOY.
- SPECIFICATION
 - TEMPERATURE RANGE: -40 TO 105°C.
 - INSULATION RESISTANCE:1000MΩ min.
 - DIELECTRIC WITHSTANDING VOLTAGE: AC 500V PER MINUTE.
- PRODUCT NUMBER CODE:
DS1022-08-X X X X

Dim. A B type
1: Type 1

CONTACT PLATING
8: FULL GOLD FLASH
6: FULL TIN

MOUNTING TYPE
V: V/T Type

No. OF CONTACTS
2*2 - 2*40
1*1 - 1*40

TABLE A:

TYPE	Dimension	
	A	B
1	7.00	3.60
2		
3		
4		
5		
6		
7		
8		
9		

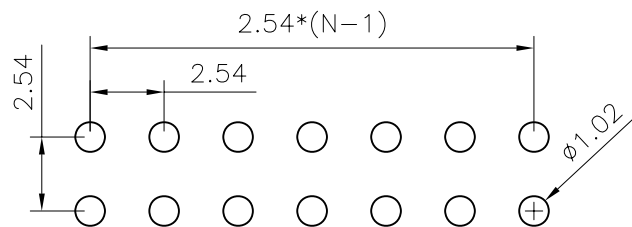
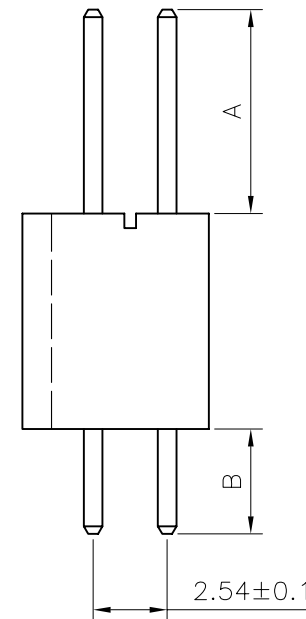
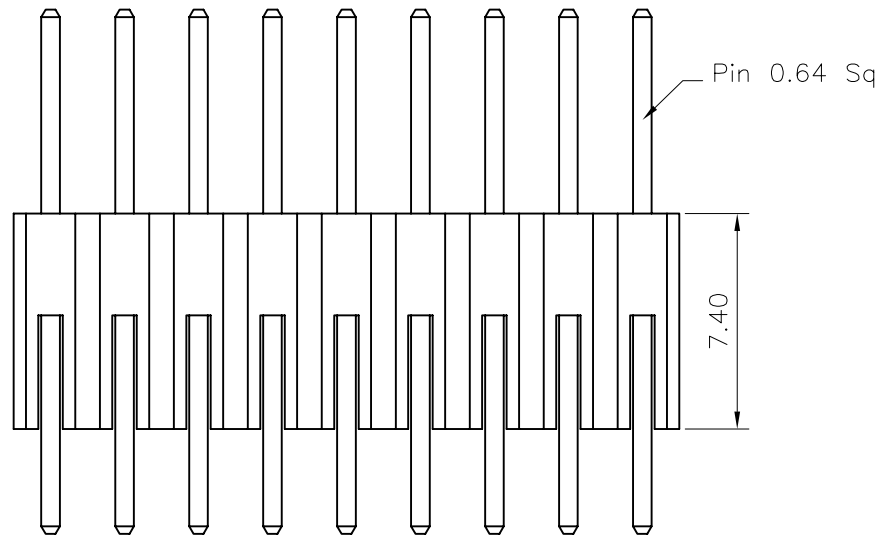
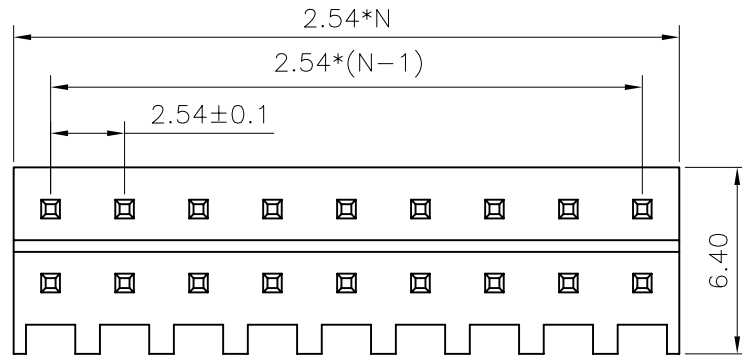

RECOMMEND PCB LAYOUT
(TOLERANCE=±0.05)

GENERAL TOLERANCE		ANGLE TOLERANCE		PROJECTION		TITLE	PIN HEADER PITCH 2.54mm	
X.	±0.60	X.	±5°	UNITS	mm		STRAIGHT TYPE H=7.4mm	
.X	±0.38	.X	±3°	SHEET SIZE	A4	SERIES	DS1022-08 SERIES	
.XX	±0.25	.XX	±2°	晨翔电子有限公司 CONNFLY CONNFLY ELECTRONIC CO. LTD				
DRAWING TYPE		CUSTOMER						
SCALE	1:1	SHEET	1 OF 1					
DRAWING NO.		C-DS1022-08-XXXX						

REV.	DESCRIPTION	DRAWN	CHECKED	APPROVED
A	NEW RELEASE	YCH 04/10/08'	~	

N:NUMBER OF CONTACTS/2

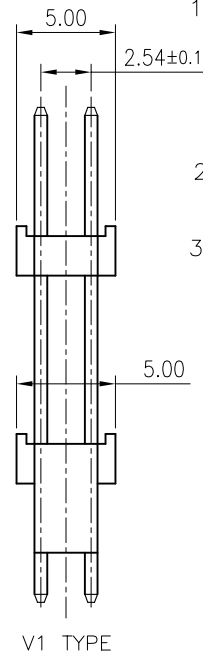
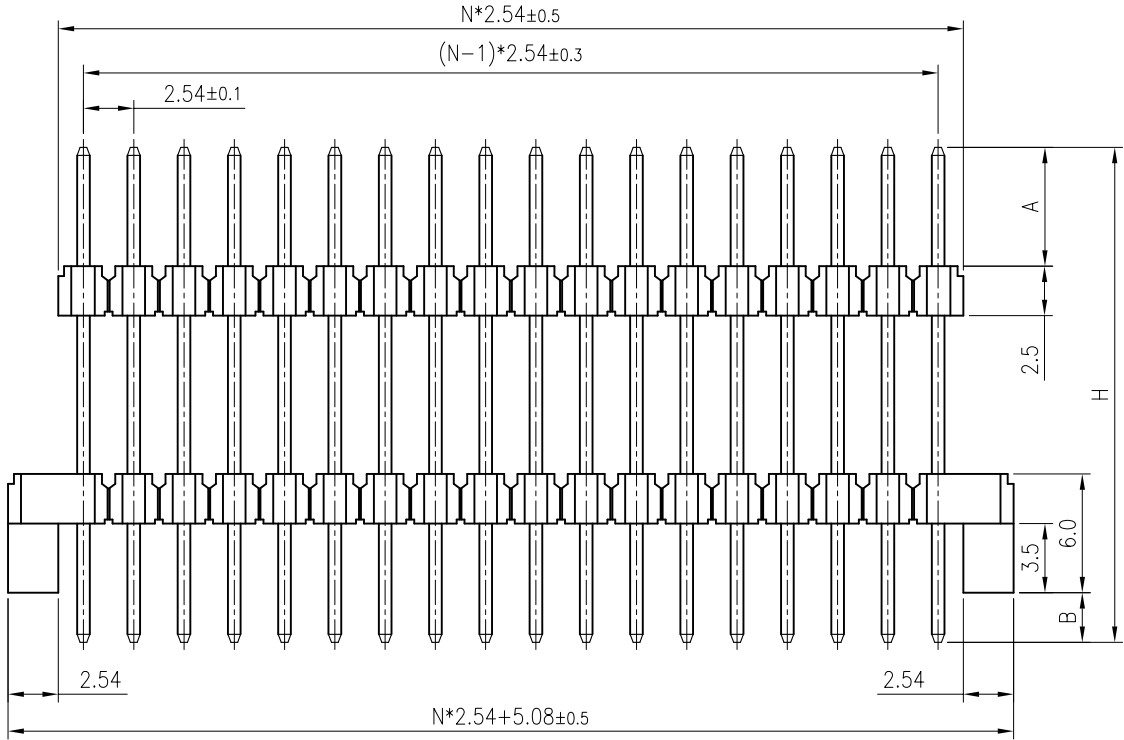

NOTES:

- ELECTRICAL CHARACTERISTICS:
 - CONTACT RESISTANCE: 20mΩ Max.
 - DIELECTRIC WITHSTANDING VOLTAGE: 500V AC(rms) FOR 1 MINUTE.
 - INSULATION RESISTANCE: 1000MΩ Min.
- ENVIRONMENT CHARACTERISTICS:
 - TEMPERATURE: -40°C~+105°C.
- PRODUCT NUMBER CODE:

DS1029-10 - X X X X X X X

 - DIM. A,B,H TYPE: 1: TYPE 1
 - HOUSING TYPE: A: V1 TYPE
 - MOUNTING TYPE: V:VERTICAL TYPE
 - HOUSING COLOR: B:BLACK
 - CONNECTOR PLATING: 8: FULL GOLD FLASH
 - CONNECT TYPE: P:PLUG
 - No.OF CONTACTS: 2*1-2*40

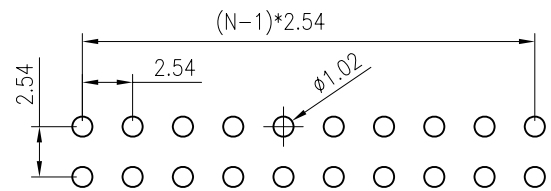
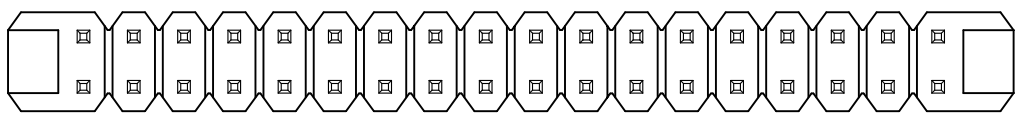

(TOLERANCE=±0.05)
RECOMMEND PCB LAYOUT

TABLE A :

TYPE	Dimension			TYPE	Dimension			TYPE	Dimension		
	A	B	C		A	B	C		A	B	C
1	6.00	2.50	25.00	6				11			
2				7				12			
3				8				13			
4				9				14			
5				10				15			

GENERAL TOLERANCE		ANGLE TOLERANCE		PROJECTION		TITLE	PIN HEADER PITCH 2.54mm	
X.	±0.60	X.	±5°	UNITS	mm		STACK TYPE WITH POST	
.X	±0.38	.X	±3°	SHEET SIZE	A4	SERIES	DS1029-10 SERIES	
.XX	±0.25	.XX	±2°			晨翔电子有限公司 CONNFLY CONNFLY ELECTRONIC CO., LTD		
DRAWING TYPE		CUSTOMER						
SCALE	1:1	SHEET	1 OF 1					
DRAWING NO.		C-DS1029-10-2*XXXX-A						

RIGHT ANGLE TYPE
N:NUMBER OF CONTACT/2

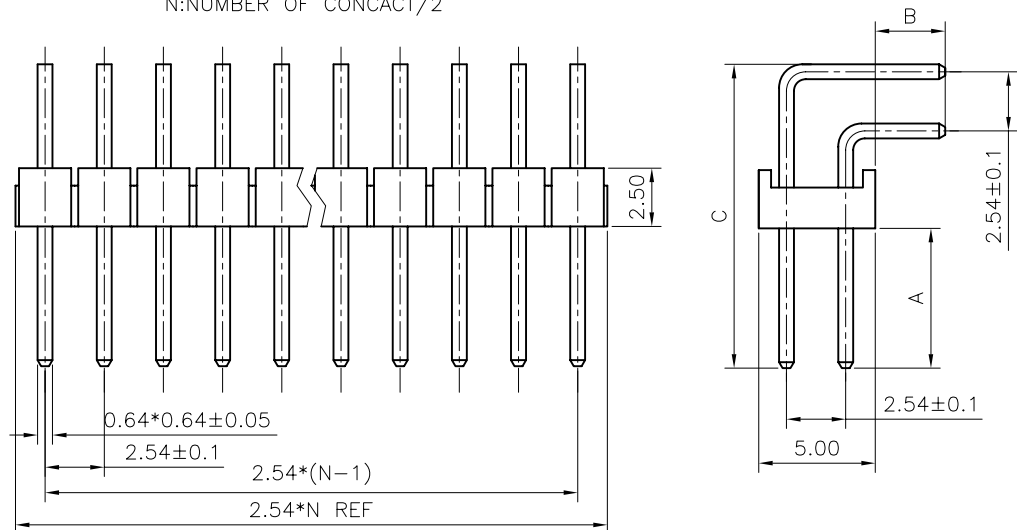

REV.	DESCRIPTION	DRAWN	CHECKED	APPROVED
A	NEW RELEASE	LJH 09/21/05'	~	LJC 09/21/05'
B,C	ADD DIM.	LJH 04/04/06'	~	LJC 04/04/06'
D	ADD DIM.	LL 09/26/06'	~	LJC 09/26/06'
E	整理图面	YCH 03/15/07'	~	LJC 03/15/07'
F	增加SMT尺寸值表格	YCH 05/18/07'	~	LJC 05/18/07'
G	整理图面	YCH 07/23/08'	~	LJC 07/23/08'
H	去除SMT类型	YCH 05/28/09'	~	

NOTES:

- MATERIAL
 - CONTACT MATERIAL: COPPER ALLOY.
 - INSULATOR:PBT OR PA-46
- SPECIFICATION
 - TEMPERATURE: -40°C~+105°C.
 - CONTACT RESISTANCE: 20mΩ max.
 - INSULATION RESISTANCE:1000MΩ min.
 - DIELECTRIC WITHSTANDING VOLTAGE: AC 500V PER MINUTE.
- PART NUMBER: DS1022
- PRODUCT NUMBER CODE:

DS1022- X X X- X
 Dim. A B C type
 1: Type 1
 7: Type 7

 CONTACT PLATING
 F1: FULL GOLD FLASH
 6: FULL TIN
 MOUNTING TYPE
 R: RIGHT ANGLE
 No. OF CONTACTS
 2*2 - 2*40
 3*2 - 3*40

RIGHT ANGLE /弯针
TABLE A:

TYPE	Dimension			Pin Length 针长 (mm)
	A	B	C	
1	6.00	3.00	13.04	14.00 19.00
2	6.10	4.00	12.94	14.80 19.90
3	6.00	4.00	12.76	14.70 19.70
4	9.00	3.00	16.04	16.90 22.00
5	6.00	3.00	13.80	14.70 19.80
6	5.10	3.00	13.04	14.00 19.00
7	6.50	3.00	13.10	14.00 19.00
8	3.00	6.00	9.32	18.30 13.20
9	3.00	3.00	10.90	11.90 16.90
10	7.00	3.10	13.90	14.90 20.00
11				

TYPE	Dimension			Pin Length 针长 (mm)
	A	B	C	
12				
13				
14				
15				
16				
17				
18				
19				
20				
21				
22				

GENERAL TOLERANCE		ANGLE TOLERANCE		PROJECTION		TITLE	PIN HEADER PITCH 2.54mm R/A TYPE		
X.	±0.60	X.	±5'	UNITS	mm				
.X	±0.38	.X	±3'	SHEET SIZE	A4	SERIES	DS1022 SERIES		
.XX	±0.25	.XX	±2'	晨翔电子有限公司 CONNFLY CONNFLY ELECTRONIC CO. LTD					
DRAWING TYPE		CUSTOMER							
SCALE	1:1	SHEET	1 OF 1						
DRAWING NO.		C-DS1022-2*XXX-X-G							

REV.	DESCRIPTION	DRAWN	CHECKED	APPROVED
A	NEW RELEASE	YCH 12/10/07'	~	

NOTES:

- MATERIAL
 - INSULATOR:THERMOPLASTIC(UL 94V-0).
 - CONTACT MATERIAL: COPPER ALLOY.
- SPECIFICATION
 - CURRENT RATING:1.5 A.
 - INSULATION RESISTANCE:1000MΩ Min.
 - DIELECTRIC WITHSTANDING:600VAC.
 - CONTACT RESISTANCE:20mΩ Max.
 - OPERATING TEMPERATURE:-40°C TO +105°C.

3. PRODUCT NUMBER CODE:
DS1022-03 - X X X X

- Dim. A B type
1: Type 1
- CONTACT PLATING
8: Full gold flash
6: Full tin
- MOUNTING TYPE
R: R/A TYPE
- No.OF CONTACTS
2*2-2*40

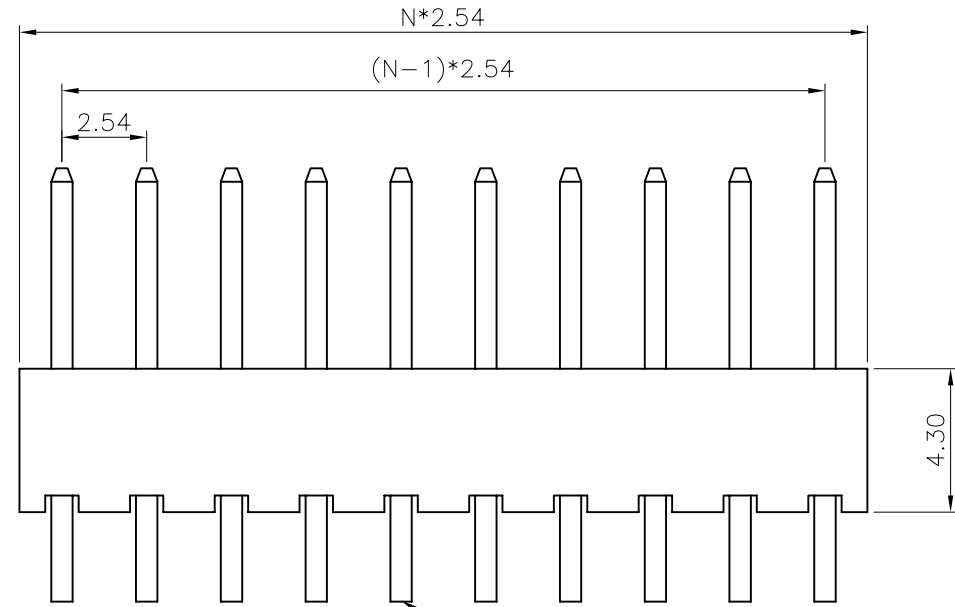
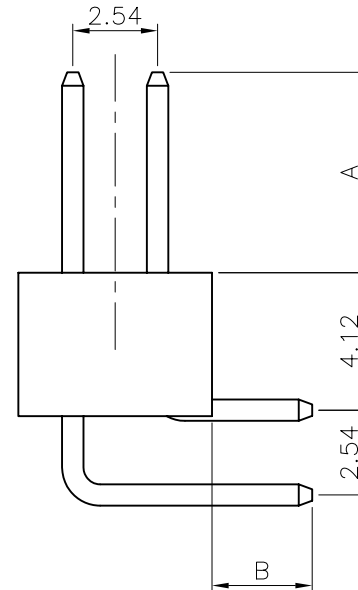

SQ PIN0.64

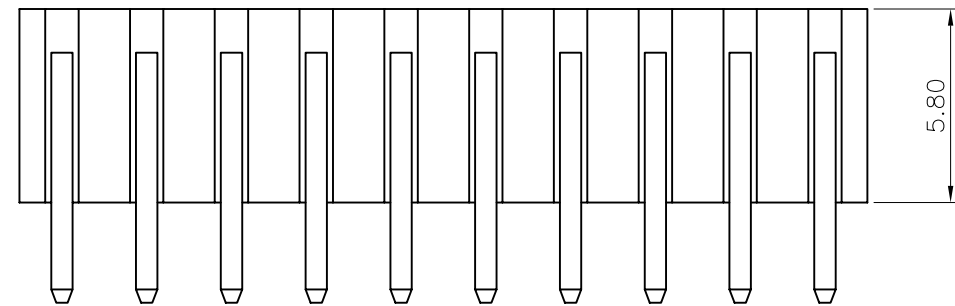
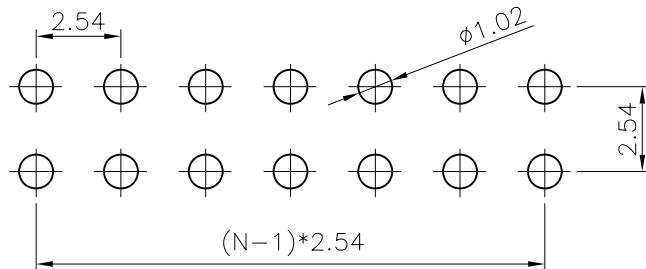



TABLE A:

TYPE	Dimension		Pin Length (mm)
	A	B	
1	6.00	3.00	14.25
			19.30
2			
3			
4			
5			
6			
7			

TYPE	Dimension		Pin Length (mm)
	A	B	
8			
9			
10			
11			
12			
13			
14			



RECOMMEND PCB LAYOUT
(TOLERANCE=±0.05)

GENERAL TOLERANCE	ANGLE TOLERANCE	PROJECTION	TITLE	PIN HEADER PITCH 2.54mm
X. ±0.60	X. ±5°	UNITS	mm	R/A TYPE H=4.3mm
.X ±0.38	.X ±3°	SHEET SIZE	A4	SERIES DS1022-03 SERIES
.XX ±0.25	.XX ±2°			
DRAWING TYPE	CUSTOMER	 晨翔电子有限公司 CONNPLY ELECTRONIC CO. LTD		
SCALE	1:1 SHEET 1 OF 1			
DRAWING NO.	C-DS1022-03-XPXXXX			

REV.	DESCRIPTION	DRAWN	CHECKED	APPROVED
A	NEW RELEASE	YCH 03/15/08'	~	

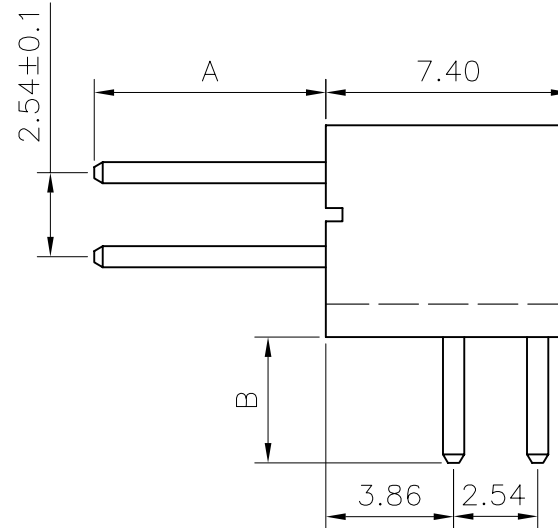
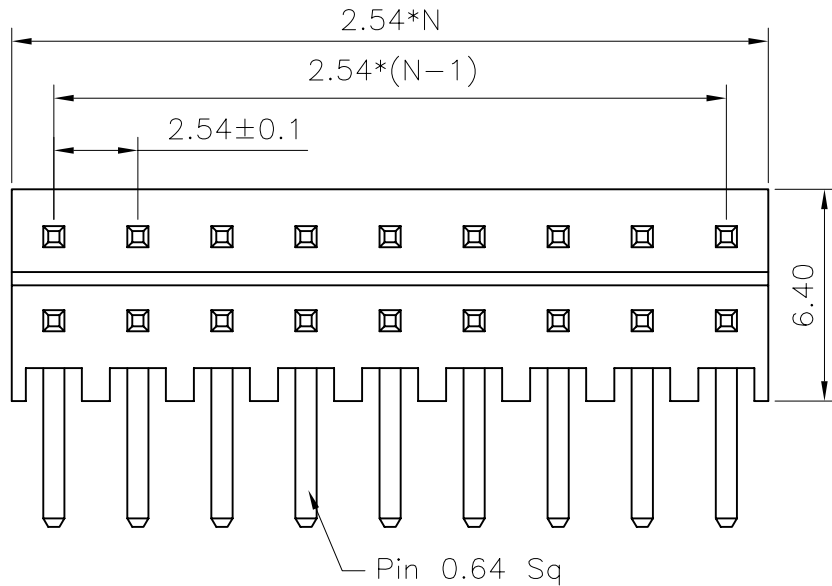

NOTES:

- MATERIAL
 - INSULATOR: THERMOPLASTIC (UL 94V-0).
 - CONTACT: COPPER ALLOY.
- SPECIFICATION
 - TEMPERATURE RANGE: -40 TO 105°C.
 - CONTACT RESISTANCE: 20mΩ max.
 - INSULATION RESISTANCE: 1000MΩ min.
 - DIELECTRIC WITHSTANDING VOLTAGE: AC 500V PER MINUTE.

3. PRODUCT NUMBER CODE:

DS1022-09- X X X X

Dim. A B type
1: Type 1

CONTACT PLATING
8: FULL GOLD FLASH
6: FULL TIN

MOUNTING TYPE
R: RIGHT ANGLE

No. OF CONTACTS
2*2 - 2*40

TABLE A:

TYPE	Dimension	
	A	B
1	7.00	3.80
2	6.00	3.00
3		
4		
5		
6		
7		
8		
9		

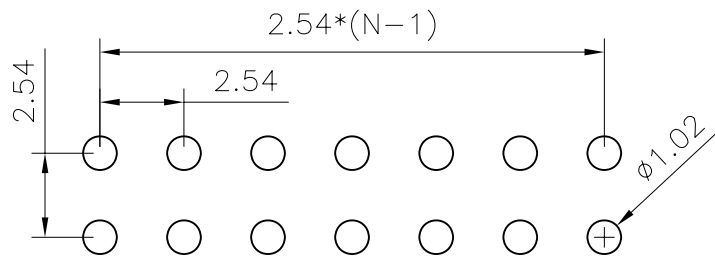

RECOMMEND PCB LAYOUT
(TOLERANCE=±0.05)

GENERAL TOLERANCE		ANGLE TOLERANCE		PROJECTION		TITLE	2.54mm PIN HEADER	
X.	±0.60	X.	±5°	UNITS	mm		RIGHT ANGLE TYPE H=7.4mm	
.X	±0.38	.X	±3°	SHEET SIZE	A4	SERIES	DS1022-09 SERIES	
.XX	±0.25	.XX	±2°	晨翔电子有限公司 CONNFLY CONNFLY ELECTRONIC CO. LTD				
DRAWING TYPE		CUSTOMER						
SCALE	1:1	SHEET	1 OF 1					
DRAWING NO.		C-DS1022-09-2*XXXX						

REV.	DESCRIPTION	DRAWN	CHECKED	APPROVED
A	NEW RELEASE	LJH 05/06/05'		

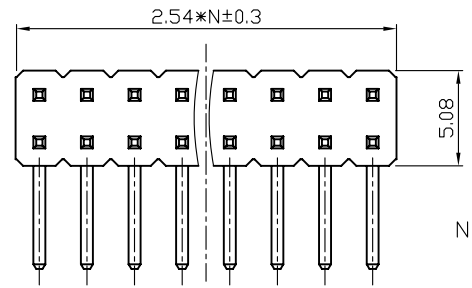

N: NUMBER OF CONTACTS/2

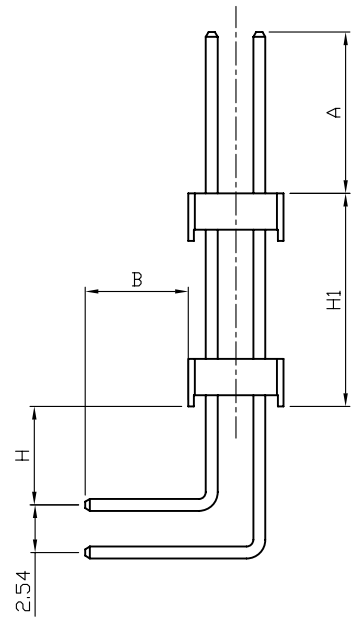
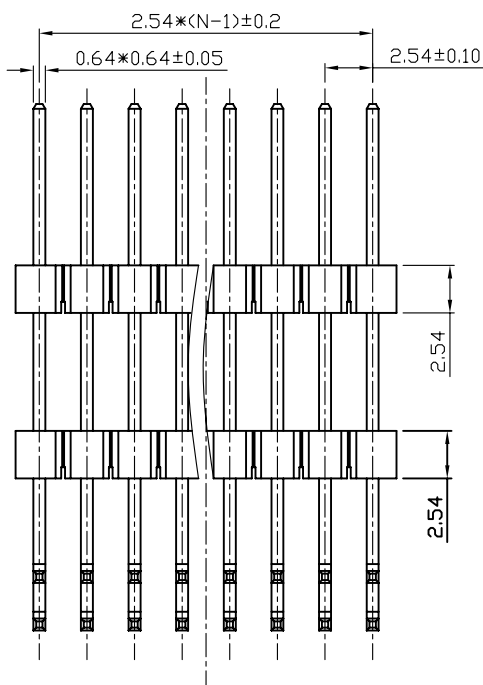

NOTES:

- MATERIAL
 - INSULATOR:THERMOPLASTIC(UL94 V-0).
 - CONTACT MATERIAL:COPPER ALLOY.
- SPECIFICATION
 - CURRENT RATING:1.5 Amp.
 - INSULATION RESISTANCE:1000MΩ Min.
 - DIELECTRIC WITHSTANDING:600VAC.
 - CONTACT RESISTANCE:50mΩ Max.
 - OPERATING TEMPERATURE:-40°C TO+105°C.

- PART NUMBER: DS1029-05
- PRODUCT NUMBER CODE:

DS1029-05 - X X X X X X
 DIM.A B H1 H2 TYPE
 1: TYPE 1
 MOUNTING TYPE
 R: RIGHT ANGLE TYPE
 HOUSING COLOR
 B:BLACK
 CONNECTOR PLATING
 8: FULL GOLD FLASH
 CONECT TYPE
 P:PLUG
 No.OF CONTACTS
 2*1-2*40

TYPE	DIM A	DIM B	DIM H1	DIM H	PIN LENGTH
1	8.60	5.50	11.37	5.25	31.50 26.40
2					
3					
4					
5					
6					

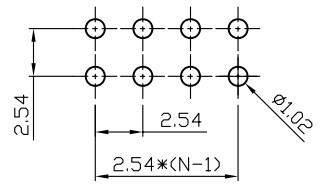

RECOMMEND PCB LAYOUT(TOLERANCE=±0.05)

GENERAL TOLERANCE		ANGLE TOLERANCE		PROJECTION		TITLE	2.54mm PITCH PIN HEADER DUAL ROW RIGHT ANGLE
X.	±0.60	X.	±5'	UNITS	mm	SHEET SIZE	A4
.X	±0.38	.X	±3'	SHEET SIZE	A4	SERIES	DS1029-05 SERIES
.XX	±0.25	.XX	±2'	晨翔电子有限公司 CONNFLY CONNFLY ELECTRONIC CO. LTD			
DRAWING TYPE		CUSTOMER					
SCALE	1:1	SHEET	1 OF 1				
DRAWING NO.		C-DS1029-05-XXXXXX					

REV.	DESCRIPTION	DRAWN	CHECKED	APPROVED
A	NEW RELEASE	LL 12/20/06'		

DUAL ROWS
 N=NUMBER OF CONTACTS/2
 C/D:CUSTOMER LENGTH AVAILABLE

- NOTES:
- MATERIAL
 - INSULATOR:THERMOPLASTIC(UL94 V-0).
 - CONTACT MATERIAL:COPPER ALLOY.
 - SPECIFICATION
 - CURRENT RATING:1.5 Amp.
 - INSULATION RESISTANCE:1000MΩ Min.
 - DIELECTRIC WITHSTANDING:600VAC.
 - CONTACT RESISTANCE:50mΩ Max.
 - OPERATING TEMPERATURE:-40°C TO+105°C.

3. PRODUCT NUMBER CODE:
 DS1029-08 - X X X X X X

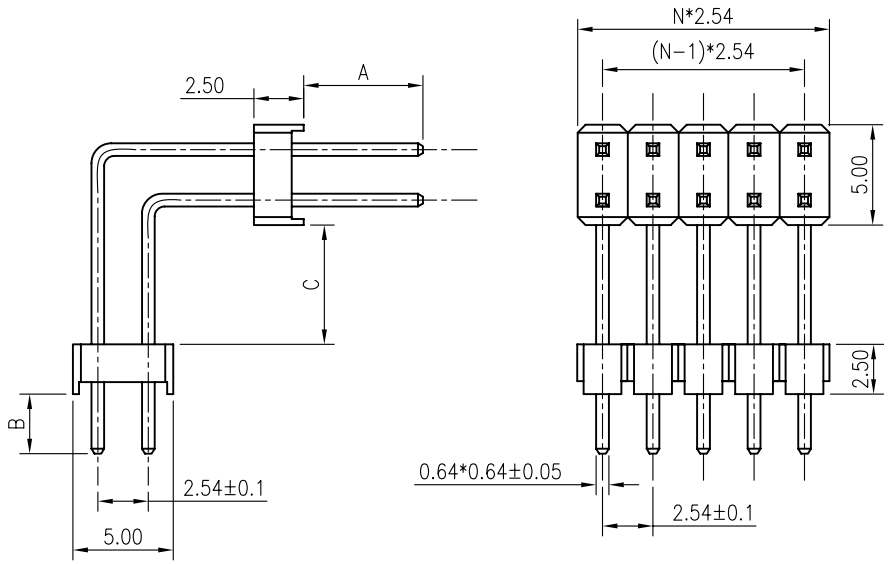
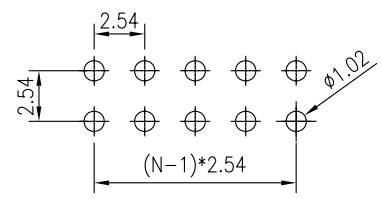

TABLE A

TYPE	Dimension			Pin Length (mm)
	A	B	C	
1	6.00	3.00	6.00	26.00 31.10
2				
3				
4				
5				
6				
7				
8				
9				

DIM.A B C YPE
 1: TYPE 1
 MOUNTING TYPE
 R: RIGHT ANGLE TYPE
 HOUSING COLOR
 B:BLACK
 CONNECTOR PLATING
 8: FULL GOLD FLASH
 CONECT TYPE
 P:PLUG
 No.OF CONTACTS
 2*1-2*40



RECOMMEND PCB LAYOUT(TOLERANCE=±0.05)

GENERAL TOLERANCE		ANGLE TOLERANCE		PROJECTION		TITLE	2.54mm PITCH PIN HEADER RIGHT ANGLE	
X	±0.60	X	±5'	UNITS	mm	SHEET SIZE	A4	SERIES
.X	±0.38	.X	±3'					DS1029-08 SERIES
.XX	±0.25	.XX	±2'					
DRAWING TYPE		CUSTOMER		晨翔电子有限公司 CONNFLY CONNFLY ELECTRONIC CO. LTD				
SCALE		1:1						
DRAWING NO.		C-DS1029-08-XXXXXX						

THREE ROWS
 N:NUMBER OF CONTACTS/3
 E/F:CUSTOMER LENGTH AVAILABLE

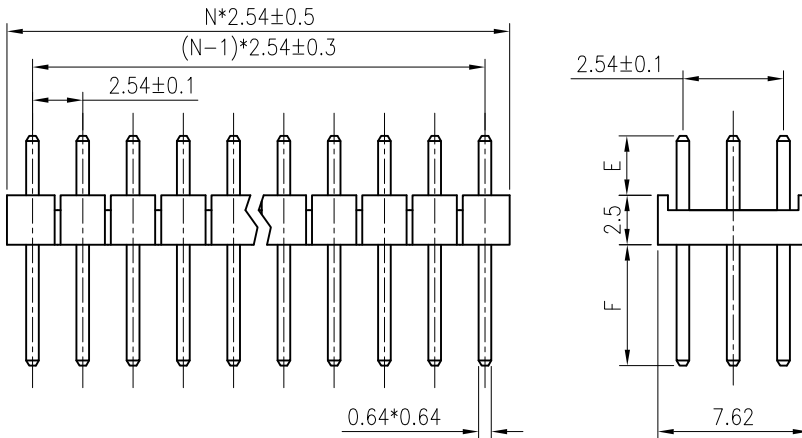

TABLE B:

TYPE	Dimension	
	E	F
1	3.00	6.10
2	7.15	7.15
3		
4		
5		
6		
7		
8		
9		
10		
11		
12		
13		
14		
15		
16		
17		
18		
19		
20		
21		
22		
23		
24		
25		
26		
27		
28		
29		

REV.	DESCRIPTION	DRAWN	CHECKED	APPROVED
A	NEW RELEASE	YCH 07/27/10'	~	

NOTES:

- ELECTRICAL CHARACTERISTICS:
 - CONTACT RESISTANCE: 20mΩ Max.
 - DIELECTRIC WITHSTANDING VOLTAGE: 500V AC(rms) FOR 1 MINUTE.
 - INSULATION RESISTANCE: 1000MΩ Min.
- ENVIRONMENT CHARACTERISTICS:
 - TEMPERATURE: -40°C~+105°C.
- PRODUCT NUMBER CODE:

DS1021- X X X X

TABLE B & DIM. TYPE
 1: TYPE 1

⋮

CONTACT PLATING
 F1: FULL GOLD FLASH
 6: TIN

MOUNTING TYPE
 S: Straight TYPE
 No. OF CONTACTS
 3*3~3*40

GENERAL TOLERANCE		ANGLE TOLERANCE		PROJECTION		TITLE	PIN HEADER PITCH 2.54mm V/T TYPE		
X.	±0.60	X.	±5'	UNITS	mm				
.X	±0.38	.X	±3'	SHEET SIZE	A4	SERIES	DS1021 SERIES		
.XX	±0.25	.XX	±2'	晨翔电子有限公司 CONNFLY CONNFLY ELECTRONIC CO. LTD					
DRAWING TYPE		CUSTOMER							
SCALE		1:1	SHEET						1 OF 1
DRAWING NO.		C-DS1021-3*XXX							

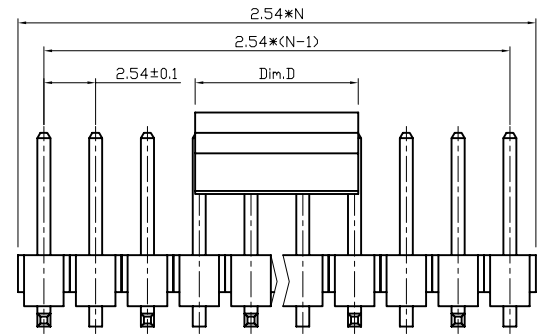
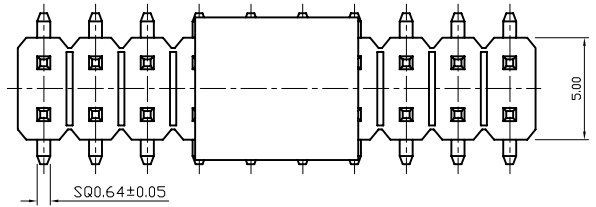
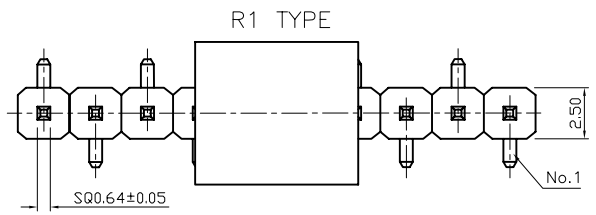
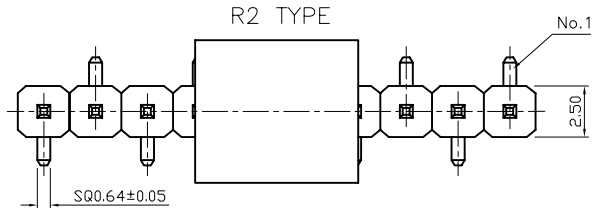

pos.	Dim.	Dim.D
2~8pin		5.0mm
9~40pin		8.0mm

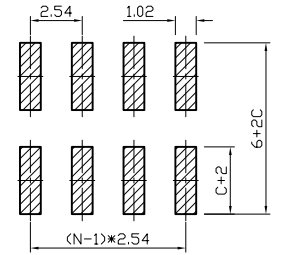
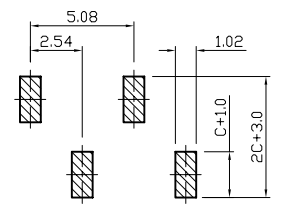
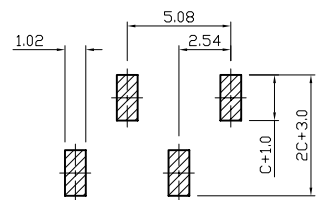

RECOMMEND PCB LAYOUT
TOLERANCE=±0.05

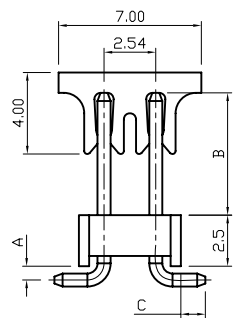

DUAL

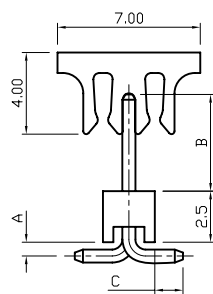

SINGLE

REV.	DESCRIPTION	DRAWN	CHECKED	APPROVED
A	NEW RELEASE	YCH 11/19/10'	~	

TABLE B:

TYPE	Dimension			Pin Length (mm)
	A	B	C	
1	1.50	6.00	3.00	13.80
2	1.20	6.00	3.00	13.50
3	0.68	7.75	1.20	12.90
4	1.20	8.00	2.50	14.90
5	1.20	6.00	1.20	11.70
6	0.70	6.00	1.40	11.30
7	1.50	6.00	1.20	11.90
8	1.00	5.84	1.40	11.60
9	1.00	8.13	1.40	13.80
10				
11				
12				
13				
14				
15				
16				
17				
18				
19				
20				
21				
22				
23				
24				
25				

NOTES:

- MATERIALS
 - CONTACT MATERIAL: COPPER ALLOY.
 - CONTACT PLATING: GOLD/TIN OVER NICKEL.
 - INSULATOR MATERIALS: PBT OR PA-46.
- SPECIFICATIONS
 - CURRENT RATING: 3 A.
 - OPERATING TEMPERATURE: -40°C TO +105°C.
 - INSULATION RESISTANCE: 1000MΩ MIN.
 - CONTACT RESISTANCE: 20mΩ MAX.
 - DIELECTRIC WITHSTANDING : 600 VAC.
- PRODUCT NUMBER CODE:

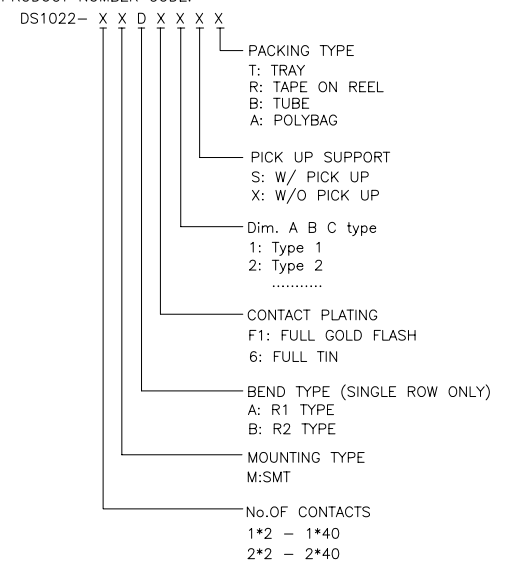

GENERAL TOLERANCE	ANGLE TOLERANCE	PROJECTION	TITLE
X. ±0.60	X. ±5°	UNITS	PIN HEADER PITCH 2.54mm SMT TYPE
.X ±0.38	.X ±3°	SHEET SIZE	A4
.XX ±0.25	.XX ±2°	SERIES	DS1022 SERIES
DRAWING TYPE	CUSTOMER		
SCALE	1:1 SHEET 1 OF 1		
DRAWING NO.	C-DS1022-XXXXXX-A		

晨翔电子有限公司
CONNFLY CONNFLY ELECTRONIC CO. LTD

REV.	DESCRIPTION	DRAWN	CHECKED	APPROVED
A	NEW RELEASE	LJH 05/06/05'		

NOTES:

- MATERIAL
 - INSULATOR:THERMOPLASTIC(UL94 V-0).
 - CONTACT MATERIAL:COPPER ALLOY.
- SPECIFICATION
 - CURRENT RATING:1.5 Amp.
 - INSULATION RESISTANCE:1000MΩ Min.
 - DIELECTRIC WITHSTANDING:600VAC.
 - CONTACT RESISTANCE:50mΩ Max.
 - OPERATING TEMPERATURE:-40°C TO+105°C.

3. PART NUMBER: DS1029-03

4. PRODUCT NUMBER CODE:

DS1029-03 - X X X X X X X

- BEND TYPE
 - 1: R1 TYPE
 - 2: R2 TYPE
- DIM.A B H1 H2 YPE
 - 1: TYPE 1
 - 2: TYPE 2
- MOUNTING TYPE
 - S: SMT TYPE
- HOUSING COLOR
 - B:BLACK
- CONNECTOR PLATING
 - 8: FULL GOLD FLASH
- CONNECT TYPE
 - P:PLUG
- No.OF CONTACTS
 - 1*1-1*40
- SERIES No.
 - DS1029-03

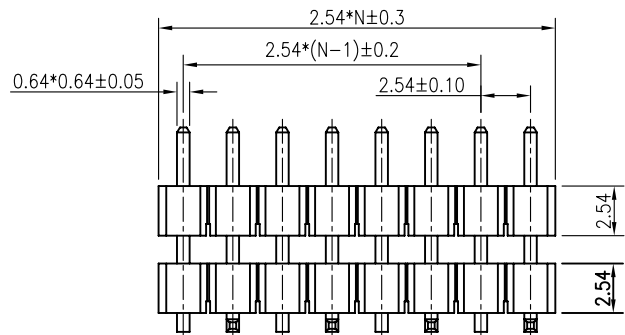
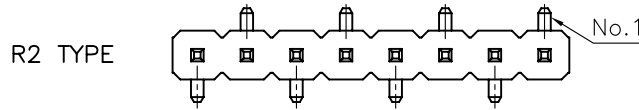
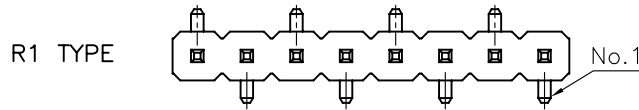

N: NUMBER OF CONTACTS

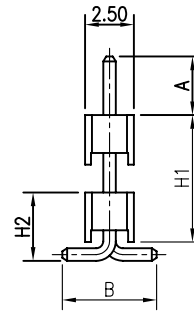

TYPE	DIM A	DIM B	DIM H1	DIM H2	LENGTH PIN
1	3.00	4.70	6.50	4.38	12.90
2	3.00	4.83	6.50	3.50	12.10
3					
4					
5					
6					
7					
8					
9					
10					
11					
12					
13					
14					

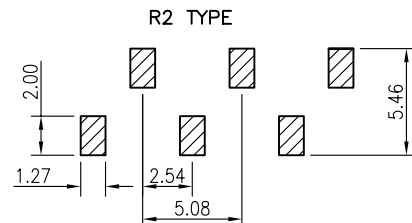
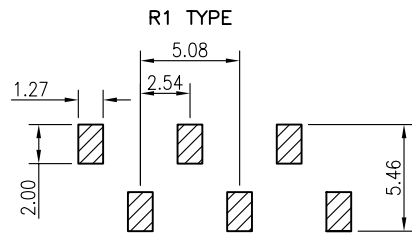

RECOMMEND PCB LAYOUT(TOLERANCE=±0.05)

GENERAL TOLERANCE	ANGLE TOLERANCE	PROJECTION		TITLE	2.54mm PITCH PIN HEADER SINGLE ROW S.M.T TYPE	
X. ±0.60	X. ±5°	UNITS	mm	SHEET SIZE	A4	
.X ±0.38	.X ±3°	SHEET SIZE	A4	SERIES	DS1029-03 SERIES	
.XX ±0.25	.XX ±2°	晨翔电子有限公司 CONNFLY CONNFLY ELECTRONIC CO. LTD				
DRAWING TYPE	CUSTOMER					
SCALE	1:1					SHEET
DRAWING NO.	C-DS1029-03-XXXXXX					

REV.	DESCRIPTION	DRAWN	CHECKED	APPROVED
A	NEW RELEASE	YCH 03/15/08'	~	

N:NUMBER OF CONTACT/2

NOTES:

- SPECIFICATION
 - TEMPERATURE RANGE: -40°C~+105°C.
 - CONTACT RESISTANCE: 20mΩ max.
 - INSULATION RESISTANCE: 1000MΩ min.
 - DIELECTRIC WITHSTANDING VOLTAGE: AC 500V PER MINUTE.
- PART NUMBER: DS1022-06
- PRODUCT NUMBER CODE:

DS1022-06- X X X X X X

- PACKING TYPE
T:TRAY
R:TAPE ON REEL
B:TUBE
A:POLYBAG
- PICK UP SUPPORT
S:W/ PICK UP
X:W/O PICK UP
- Dim. A B C type
1: Type 1
.....
- CONTACT PLATING
8: FULL GOLD FLASH
6: FULL TIN
- MOUNTING TYPE
S: SMT
- No. OF CONTACTS
2*2 - 2*40

TABLE A:

TYPE	Dimension	
	B	C
1	6.00	7.50
2		
3		
4		
5		
6		
7		
8		

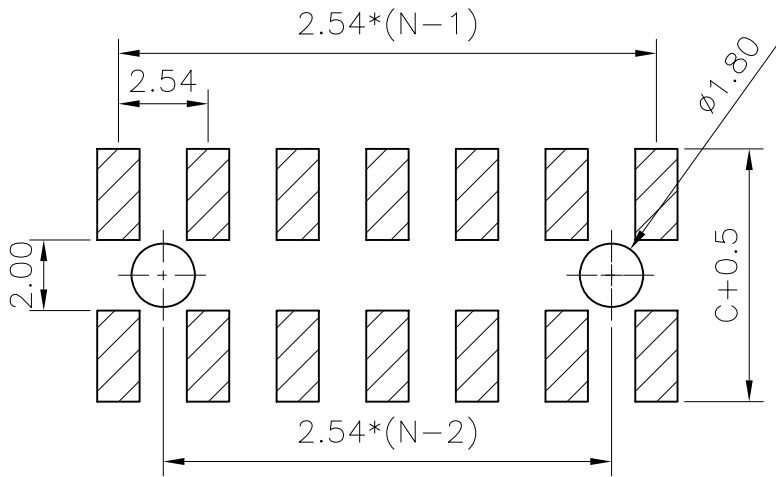
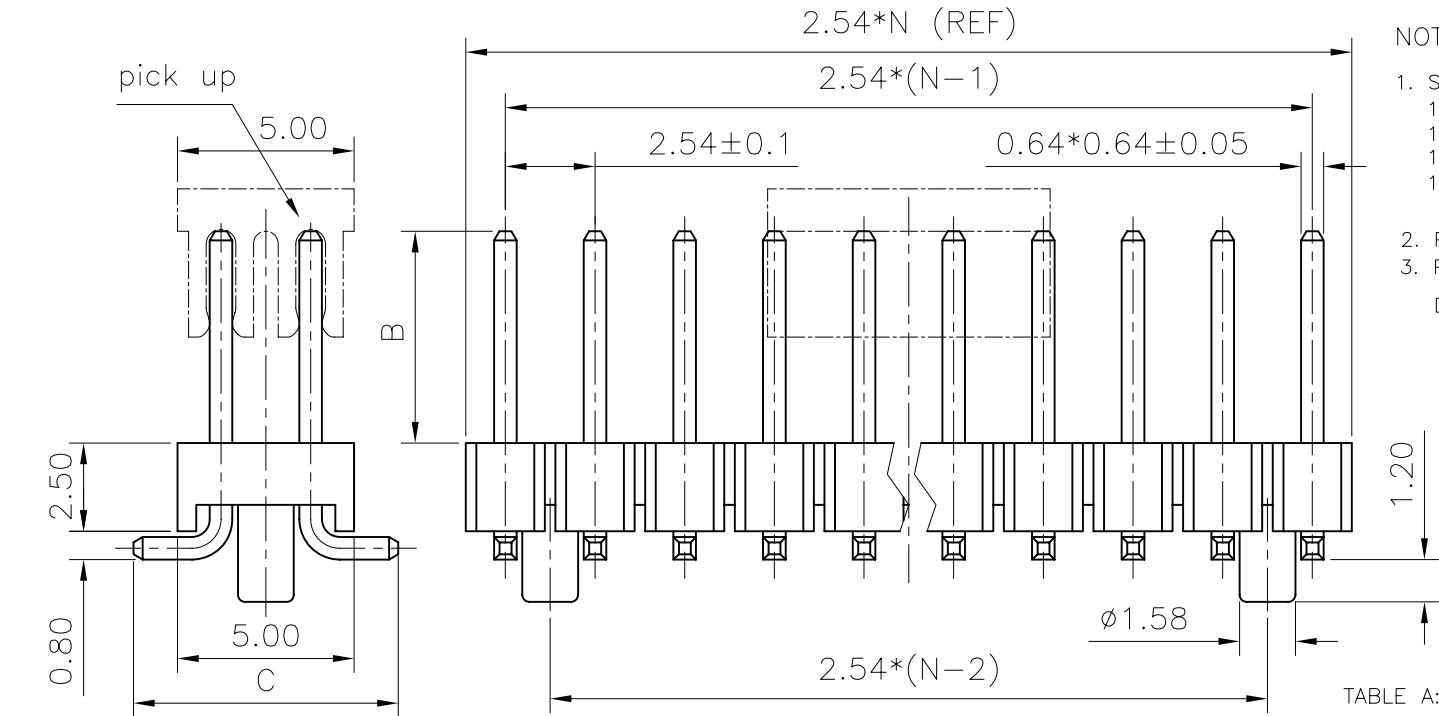

GENERAL TOLERANCE		ANGLE TOLERANCE	
X.	±0.60	X.	±5°
.X	±0.38	.X	±3°
.XX	±0.25	.XX	±2°

DRAWING TYPE	CUSTOMER		
SCALE	1:1	SHEET	1 OF 1
DRAWING NO.	C-DS1022-06-2*XXXXXX		

PROJECTION	TITLE	PIN HEADER PITCH 2.54mm	
UNITS	mm	SMT TYPE W/ POST	
SHEET SIZE	A4	SERIES	DS1022-06 SERIES

晨翔电子有限公司
CONNFLY CONNFLY ELECTRONIC CO. LTD

REV.	DESCRIPTION	DRAWN	CHECKED	APPROVED
A	NEW RELEASE	YCH 12/10/07'	~	

NOTES:

- MATERIAL
 - INSULATOR:THERMOPLASTIC(UL 94V-0).
 - CONTACT MATERIAL: COPPER ALLOY.
- SPECIFICATION
 - CURRENT RATING:1.5 A.
 - INSULATION RESISTANCE:1000MΩ Min.
 - DIELECTRIC WITHSTANDING:600VAC.
 - CONTACT RESISTANCE:20mΩ Max.
 - OPERATING TEMPERATURE:-40°C TO +105°C.
- PRODUCT NUMBER CODE:
DS1022-04 - X X X X

Dim. A B type
1: Type 1
CONTACT PLATING
8: Full gold flash
6: Full Tin
MOUNTING TYPE
S: SMT TYPE
No.OF CONTACTS
2*2-2*40

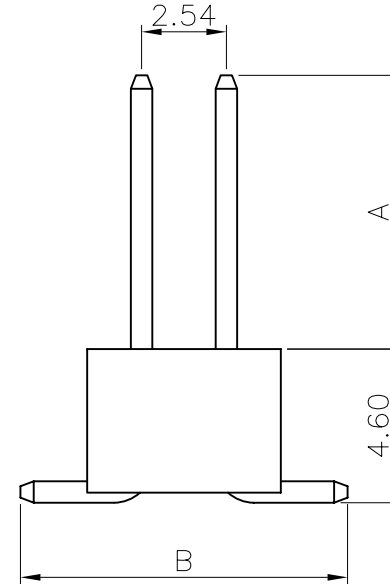
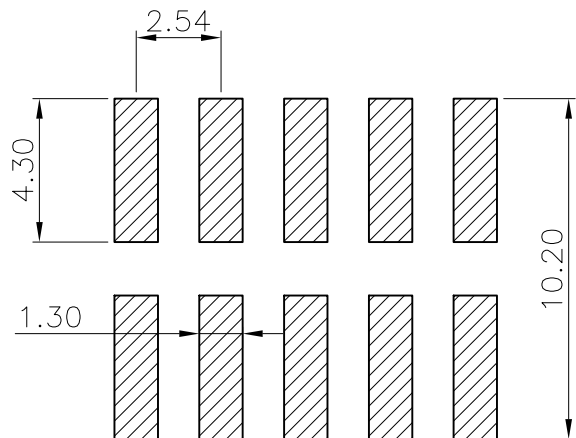
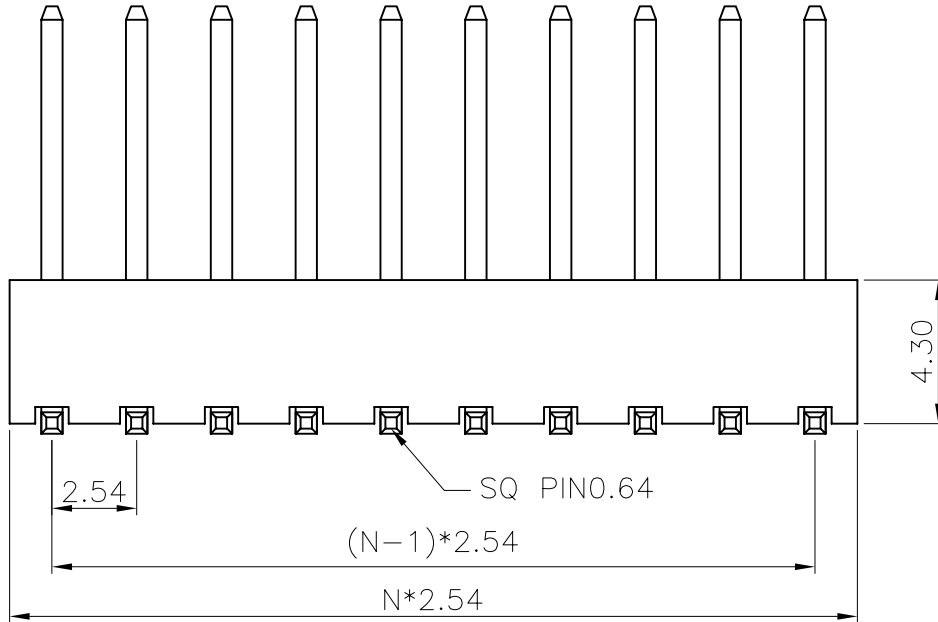
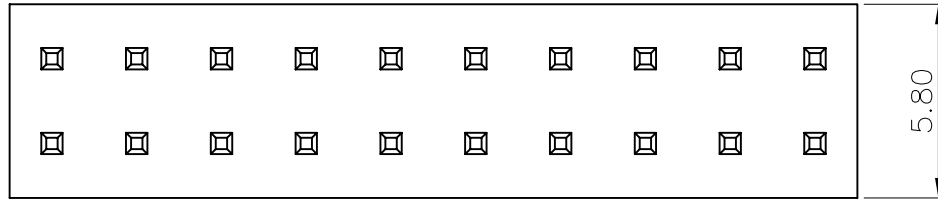

TABLE A:

TYPE	Dimension		Pin Length (mm)	TYPE	Dimension		Pin Length (mm)
	A	B			A	B	
1	8.20	9.80	15.60	8			
2				9			
3				10			
4				11			
5				12			
6				13			
7				14			



RECOMMEND PCB LAYOUT
(TOLERANCE=±0.05)

GENERAL TOLERANCE		ANGLE TOLERANCE		PROJECTION		TITLE	PIN HEADER PITCH 2.54mm	
X.	±0.60	X.	±5°	UNITS	mm		SMT TYPE H=4.3mm	
.X	±0.38	.X	±3°	SHEET SIZE	A4	SERIES	DS1022-04 SERIES	
.XX	±0.25	.XX	±2°	晨翔电子有限公司 CONNPLY ELECTRONIC CO. LTD				
DRAWING TYPE		CUSTOMER						
SCALE	1:1	SHEET	1 OF 1					
DRAWING NO.		C-DS1022-04-XXXX						

REV.	DESCRIPTION	DRAWN	CHECKED	APPROVED
A	NEW RELEASE	LL 09/12/06'		

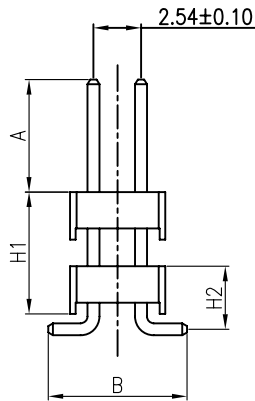
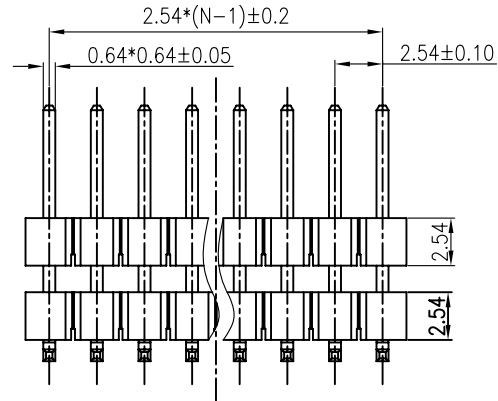
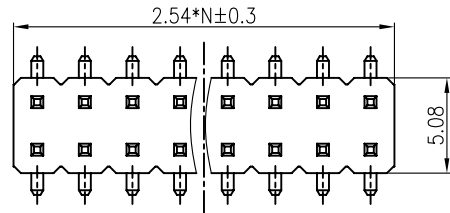

N:NUMBER OF CONTACTS/2

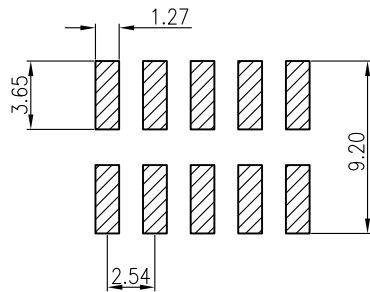

RECOMMEND PCB LAYOUT(TOLERANCE=±0.05)

NOTES:

- MATERIAL
 - INSULATOR:THERMOPLASTIC(UL94 V-0).
 - CONTACT MATERIAL:COPPER ALLOY.
- SPECIFICATION
 - CURRENT RATING:1.5 Amp.
 - INSULATION RESISTANCE:1000MΩ Min.
 - DIELECTRIC WITHSTANDING:600VAC.
 - CONTACT RESISTANCE:50mΩ Max.
 - OPERATING TEMPERATURE:-40°C TO+105°C.
- PART NUMBER: DS1029-06
- PRODUCT NUMBER CODE:

DS1029-06 - X X X X X X

- DIM.A B H1 H2 TYPE
- 1: TYPE 1
- 2: TYPE 2
- 3: TYPE 3
- MOUNTING TYPE
- S: SMT TYPE
- HOUSING COLOR
- B:BLACK
- CONNECTOR PLATING
- 8: FULL GOLD FLASH
- CONECT TYPE
- P:PLUG
- No.OF CONTACTS
- 2*1-2*40
- SERIES No.
- DS1029-06

TYPE	DIM A	DIM B	DIM H1	DIM H2	PIN LENGTH
1	6.00	7.40	6.50	3.36	15.30
2	6.00	7.40	15.00	3.36	23.80
3	5.80	7.40	6.50	3.81	15.60
4					
5					
6					
7					
8					
9					
10					
11					

GENERAL TOLERANCE		ANGLE TOLERANCE		PROJECTION		TITLE	2.54mm PITCH PIN HEADER
X.	±0.60	X.	±5°	UNITS	mm	DUAL ROW S.M.T	
.X	±0.38	.X	±3°	SHEET SIZE	A4	SERIES	DS1029-06 SERIES
.XX	±0.25	.XX	±2°	 晨翔电子有限公司 CONNFLY CONNFLY ELECTRONIC CO. LTD			
DRAWING TYPE		CUSTOMER					
SCALE	1:1	SHEET	1 OF 1				
DRAWING NO.		C-DS1029-06-XXXXXX					

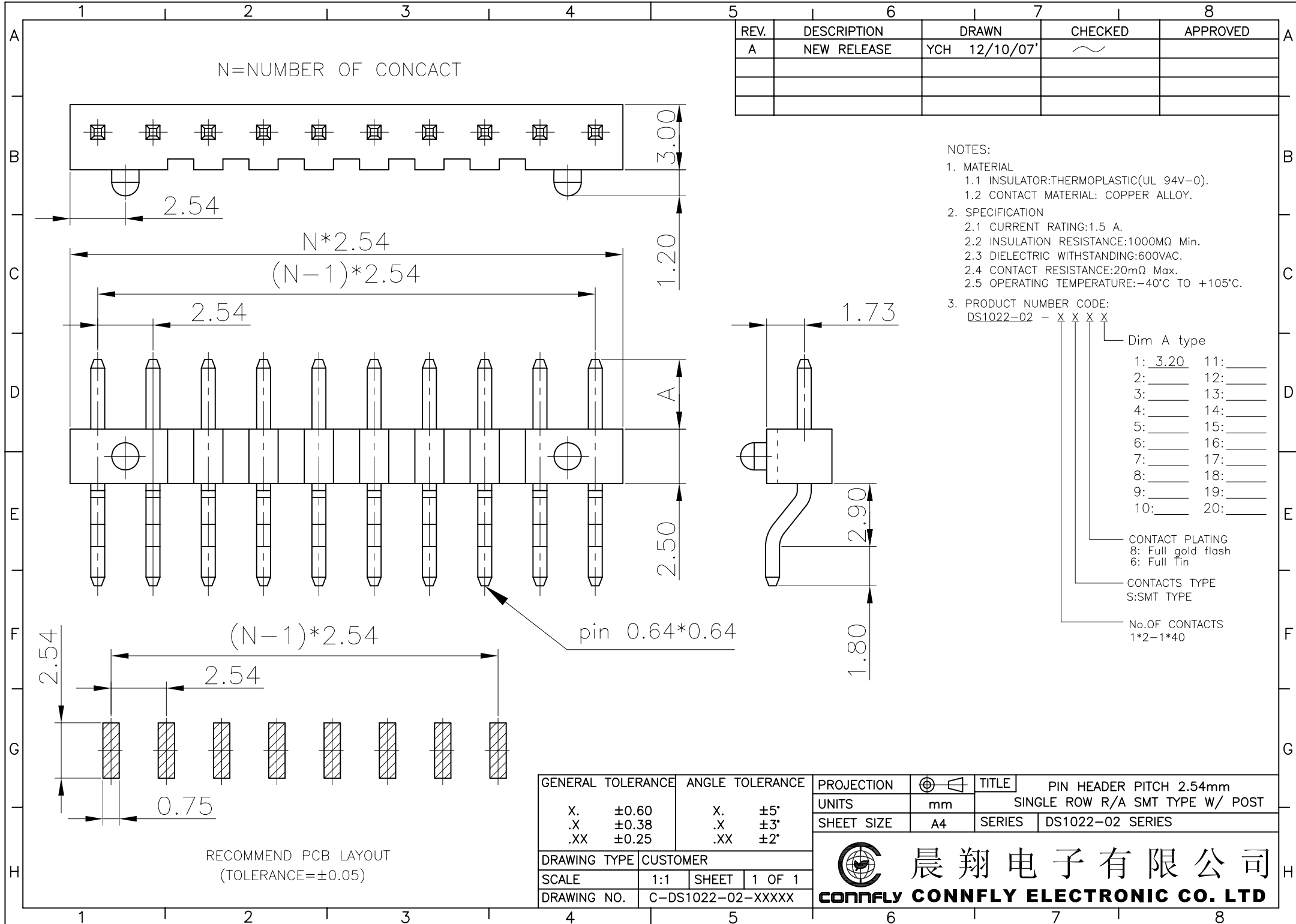

N=NUMBER OF CONTACT

REV.	DESCRIPTION	DRAWN	CHECKED	APPROVED
A	NEW RELEASE	YCH 12/10/07'	~	

- NOTES:
- MATERIAL
 - INSULATOR:THERMOPLASTIC(UL 94V-0).
 - CONTACT MATERIAL: COPPER ALLOY.
 - SPECIFICATION
 - CURRENT RATING:1.5 A.
 - INSULATION RESISTANCE:1000MΩ Min.
 - DIELECTRIC WITHSTANDING:600VAC.
 - CONTACT RESISTANCE:20mΩ Max.
 - OPERATING TEMPERATURE:-40°C TO +105°C.
 - PRODUCT NUMBER CODE:
DS1022-02 - X X X X

- Dim A type
- | | |
|-----------|-----------|
| 1: 3.20 | 11: _____ |
| 2: _____ | 12: _____ |
| 3: _____ | 13: _____ |
| 4: _____ | 14: _____ |
| 5: _____ | 15: _____ |
| 6: _____ | 16: _____ |
| 7: _____ | 17: _____ |
| 8: _____ | 18: _____ |
| 9: _____ | 19: _____ |
| 10: _____ | 20: _____ |

CONTACT PLATING
8: Full gold flash
6: Full Tin

CONTACTS TYPE
S:SMT TYPE

No.OF CONTACTS
1*2-1*40

GENERAL TOLERANCE		ANGLE TOLERANCE		PROJECTION		TITLE	PIN HEADER PITCH 2.54mm	
X.	±0.60	X.	±5°	UNITS	mm	SINGLE ROW R/A SMT TYPE W/ POST		
.X	±0.38	.X	±3°	SHEET SIZE	A4	SERIES	DS1022-02 SERIES	
.XX	±0.25	.XX	±2°	晨翔电子有限公司 CONNPLY ELECTRONIC CO. LTD				
DRAWING TYPE		CUSTOMER						
SCALE	1:1	SHEET	1 OF 1					
DRAWING NO.		C-DS1022-02-XXXXX						

RECOMMEND PCB LAYOUT
(TOLERANCE=±0.05)

REV.	DESCRIPTION	DRAWN	CHECKED	APPROVED
A	NEW RELEASE	YCH 03/15/08'	~	

N=NUMBER OF CONTACT

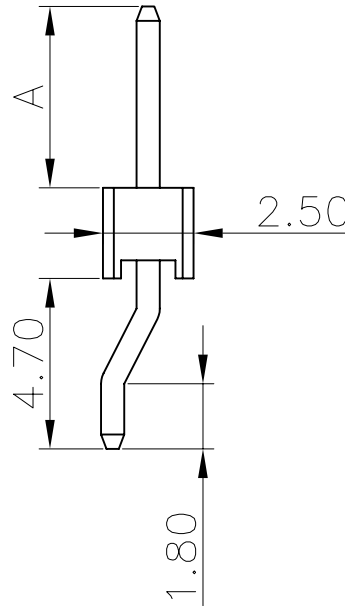
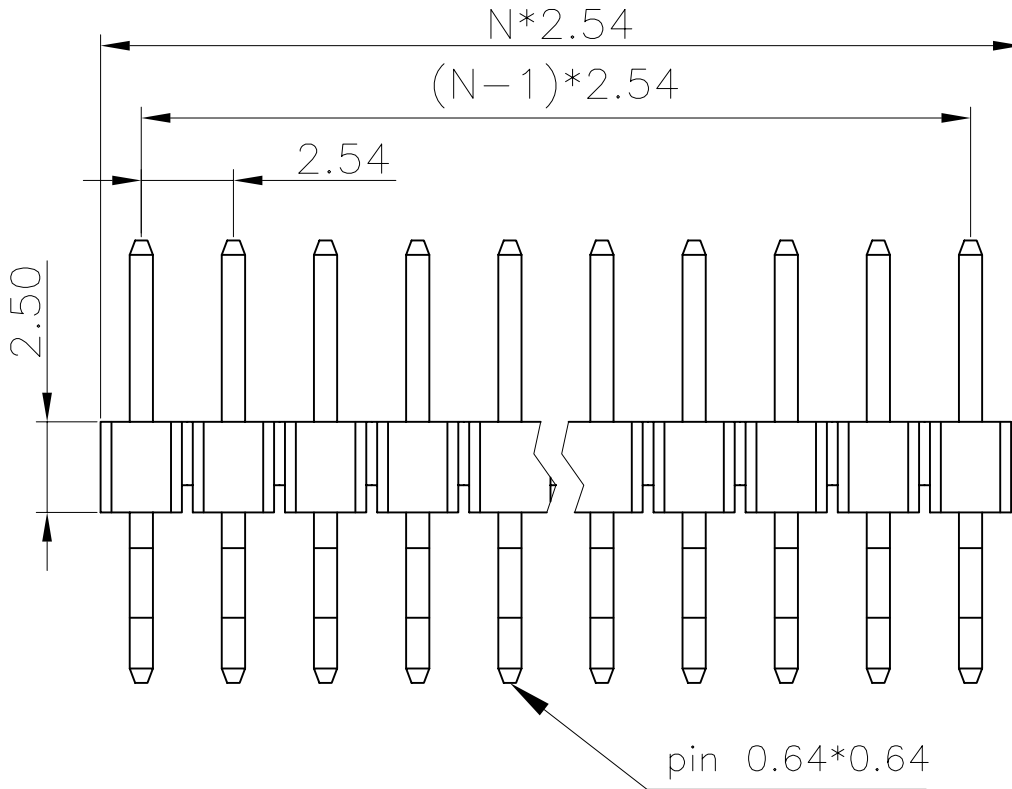

NOTES:

- MATERIAL
 - INSULATOR:THERMOPLASTIC(UL 94V-0).
 - CONTACT MATERIAL: COPPER ALLOY.
- SPECIFICATION
 - CURRENT RATING:1.5 A.
 - INSULATION RESISTANCE:1000MΩ Min.
 - DIELECTRIC WITHSTANDING:600VAC.
 - CONTACT RESISTANCE:20mΩ Max.
 - TEMPERATURE RANGE:-40°C TO +105°C.
- PRODUCT NUMBER CODE:
DS1022-07 - X X X X

Dim A type

- | | |
|----------------|-----------|
| 1: <u>3.20</u> | 11: _____ |
| 2: <u>6.00</u> | 12: _____ |
| 3: _____ | 13: _____ |
| 4: _____ | 14: _____ |
| 5: _____ | 15: _____ |
| 6: _____ | 16: _____ |
| 7: _____ | 17: _____ |
| 8: _____ | 18: _____ |
| 9: _____ | 19: _____ |
| 10: _____ | 20: _____ |

CONTACTS TYPE
8: Full gold flash
6: Full Tin

MOUNTING TYPE
S:SMT TYPE

No.OF CONTACTS
1*2-1*40

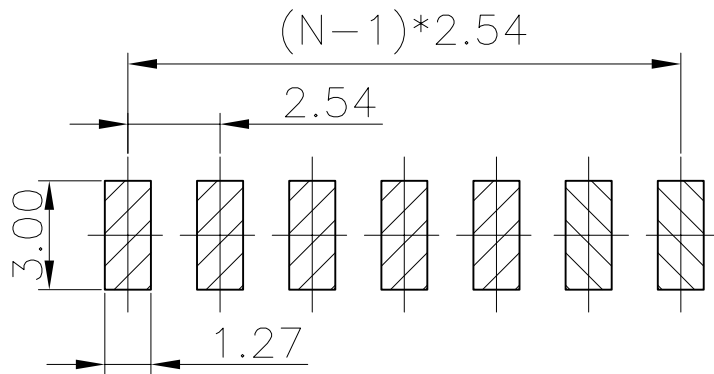

RECOMMEND PCB LAYOUT
(TOLERANCE=±0.05)

GENERAL TOLERANCE		ANGLE TOLERANCE	
X.	±0.60	X.	±5°
.X	±0.38	.X	±3°
.XX	±0.25	.XX	±2°

PROJECTION	TITLE
UNITS	PIN HEADER PITCH 2.54mm
SHEET SIZE	SINGLE ROW SMT TYPE W/O POST
	SERIES DS1022-07 SERIES

DRAWING TYPE	CUSTOMER		
SCALE	1:1	SHEET	1 OF 1
DRAWING NO.	C-DS1022-07-XXXX		



晨翔电子有限公司

CONFLY CONFLY ELECTRONIC CO. LTD

REV.	DESCRIPTION	DRAWN	CHECKED	APPROVED
A	NEW RELEASE	YCH 12/10/07'	~	

NOTES:

- MATERIAL
 - INSULATOR:THERMOPLASTIC(UL 94V-0).
 - CONTACT MATERIAL: COPPER ALLOY.
- SPECIFICATION
 - CURRENT RATING:1.5 A.
 - INSULATION RESISTANCE:1000MΩ Min.
 - DIELECTRIC WITHSTANDING:600VAC.
 - CONTACT RESISTANCE:20mΩ Max.
 - TEMPERATURE RANGE:-40°C~+105°C.

3. PRODUCT NUMBER CODE:
DS1022-01 - X X X X

Dim A type

1:	7.10	11:	_____
2:	_____	12:	_____
3:	_____	13:	_____
4:	_____	14:	_____
5:	_____	15:	_____
6:	_____	16:	_____
7:	_____	17:	_____
8:	_____	18:	_____
9:	_____	19:	_____
10:	_____	20:	_____

CONTACT PLATING
8: Full gold flash
6: Full Tin

CONTACTS TYPE
S: SMT TYPE

No.OF CONTACTS
2*2-2*40

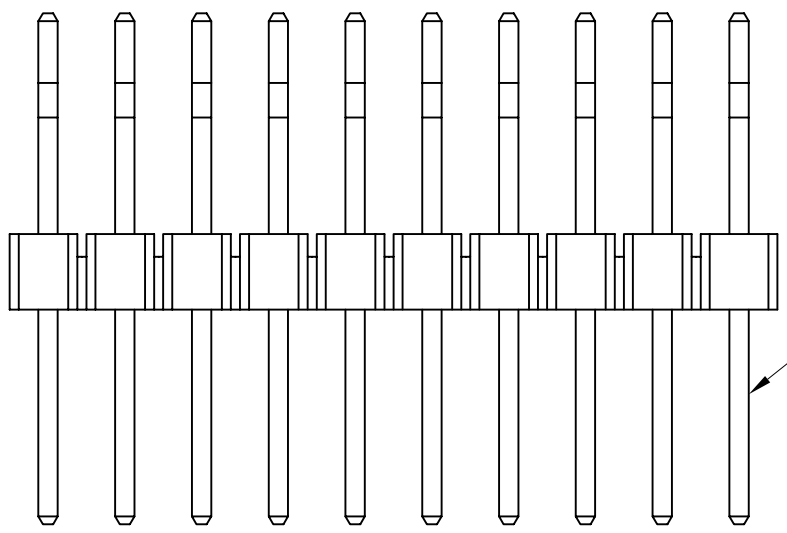

SQ PIN0.64

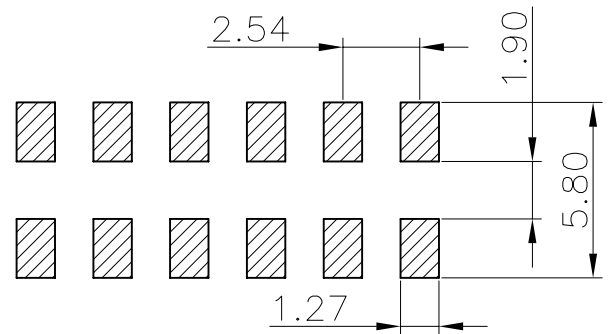
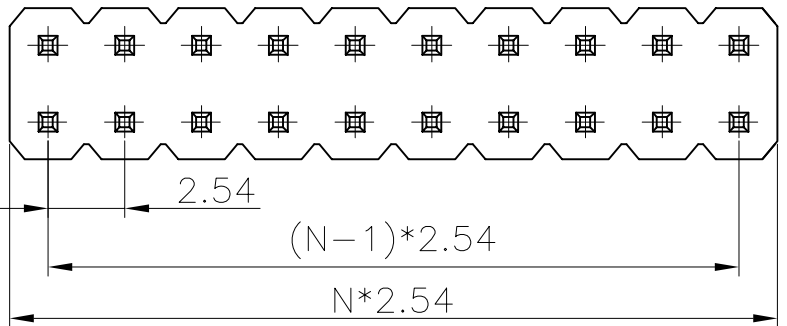
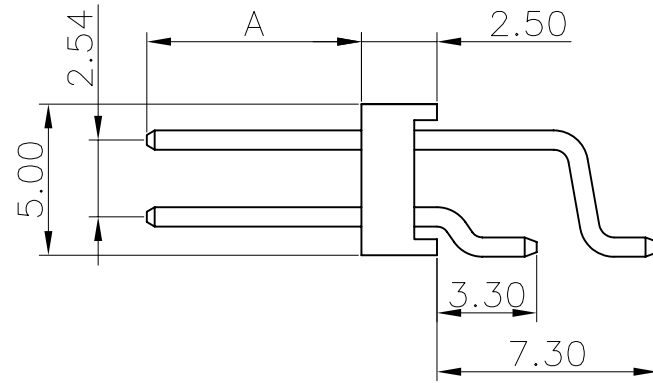

RECOMMEND PCB LAYOUT
(TOLERANCE=±0.05)

GENERAL TOLERANCE		ANGLE TOLERANCE	
X.	±0.60	X.	±5°
.X	±0.38	.X	±3°
.XX	±0.25	.XX	±2°

PROJECTION	TITLE
UNITS	PIN HEADER PITCH 2.54mm
SHEET SIZE	2 ROWS R/A SMT TYPE
	SERIES DS1022-01 SERIES

DRAWING TYPE	CUSTOMER
SCALE	1:1 SHEET 1 OF 1
DRAWING NO.	C-DS1022-01-XXXX

晨翔电子有限公司
CONFLY CONFLY ELECTRONIC CO. LTD

REV.	DESCRIPTION	DRAWN	CHECKED	APPROVED
A	NEW RELEASE	YCH 12/10/07'	~	

NOTES:

- MATERIAL
 - INSULATOR:THERMOPLASTIC(UL 94V-0).
 - CONTACT MATERIAL: COPPER ALLOY.
- SPECIFICATION
 - CURRENT RATING:1.5 A.
 - INSULATION RESISTANCE:1000MΩ Min.
 - DIELECTRIC WITHSTANDING:600VAC.
 - CONTACT RESISTANCE:20mΩ Max.
 - OPERATING TEMPERATURE:-40°C TO +105°C.

3. PRODUCT NUMBER CODE:
DS1022-10 - X X X X

Dim A type

1:	5.84	11:	_____
2:	_____	12:	_____
3:	_____	13:	_____
4:	_____	14:	_____
5:	_____	15:	_____
6:	_____	16:	_____
7:	_____	17:	_____
8:	_____	18:	_____
9:	_____	19:	_____
10:	_____	20:	_____

CONTACT PLATING
8: Full gold flash
6: Full Tin

MOUNTING TYPE
S: SMT TYPE

No.OF CONTACTS
2*2-2*40

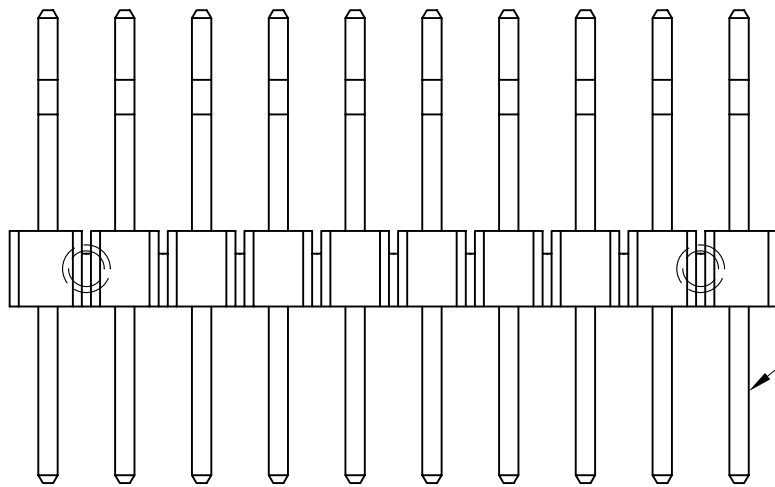

SQ PIN0.64

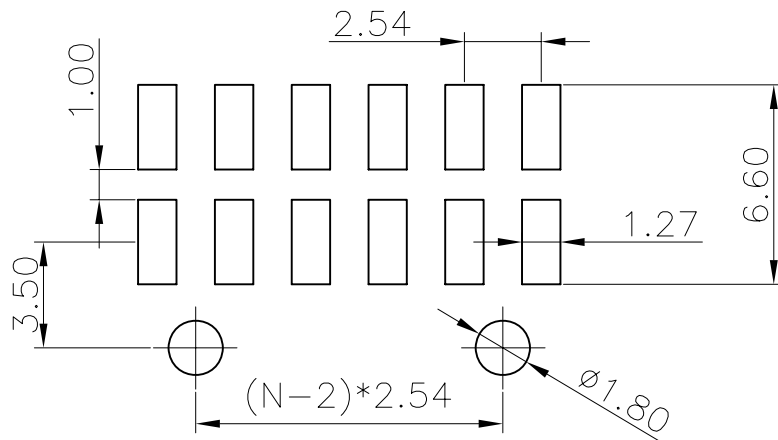
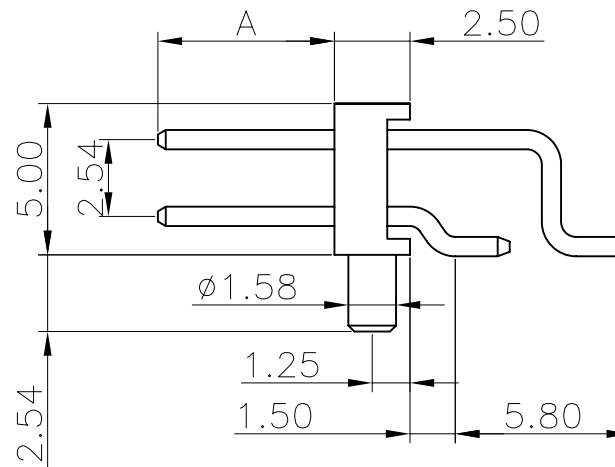
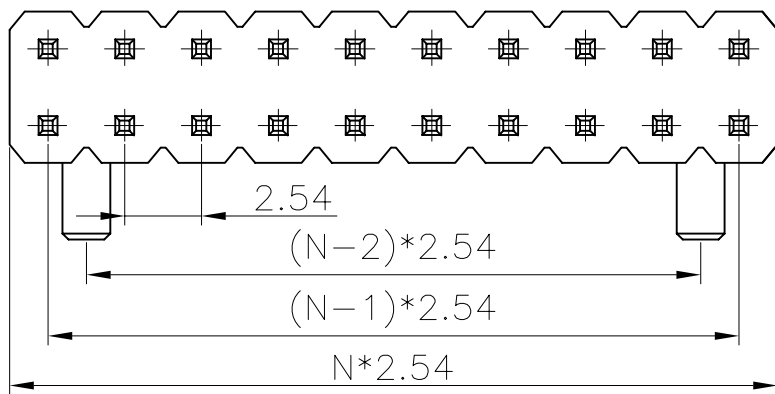

RECOMMEND PCB LAYOUT
(TOLERANCE=±0.05)

GENERAL TOLERANCE		ANGLE TOLERANCE	
X.	±0.60	X.	±5°
.X	±0.38	.X	±3°
.XX	±0.25	.XX	±2°

PROJECTION	TITLE	PIN HEADER PITCH 2.54mm	
UNITS	mm	R/A SMT TYPE W/ POST	
SHEET SIZE	A4	SERIES	DS1022-10 SERIES

DRAWING TYPE	CUSTOMER		
SCALE	1:1	SHEET	1 OF 1
DRAWING NO.	C-DS1022-10-XXXXX		

晨翔电子有限公司
CONFLY CONFLY ELECTRONIC CO. LTD