

REV.	DESCRIPTION	DRAWN	CHECKED	APPROVED
A	NEW RELEASE	YCH 10/22/09'	~	

NOTES:

- ELECTRICAL CHARACTERISTICS:
 - CONTACT RESISTANCE: 20mΩ Max. INITIAL.
 - DIELECTRIC WITHSTANDING VOLTAGE: 500V AC(rms) FOR 1 MINUTE.
 - INSULATION RESISTANCE: 1000MΩ Min.
- MECHANICAL CHARACTERISTICS:
 - CONTACT RETENTION FORCE: 500gf Min.
- ENVIRONMENT CHARACTERISTICS:
 - TEMPERATURE RANGE: -40°C ~ +105°C.
- PRODUCT NUMBER CODE:

DS1023- X X X X

- PROFILE HEIGHT(DIM A)
1: 8.5mm
- CONTACT PLATING
0: SELETIVE GOLD FLASH
F1: FULL GOLD FLASH
2: NICKEL + GOLD FLASH
- MOUNTIING TYPE
S: Straight TYPE
- No.OF CONTACTS
1*1-1*40
2*2-2*40
3*3-3*40

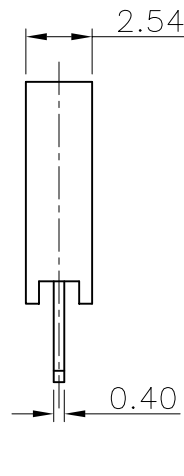
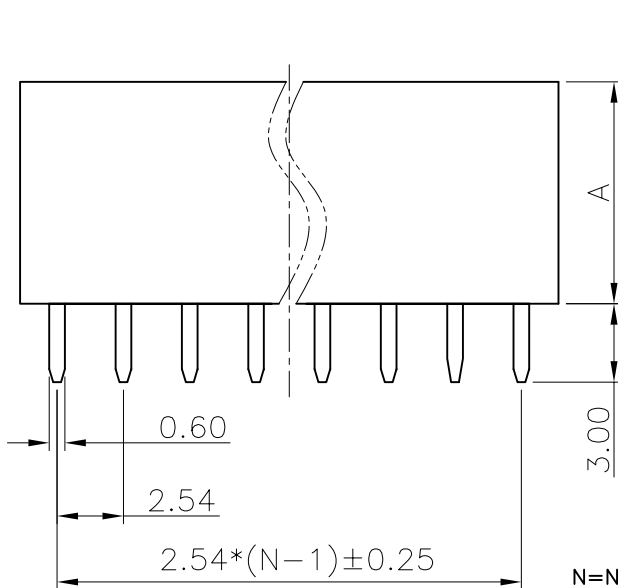
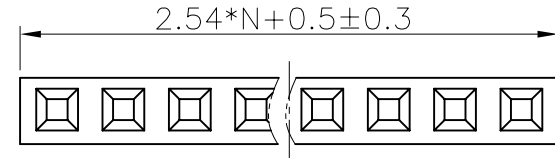

SINGLE ROW
N=No. OF CONTACTS

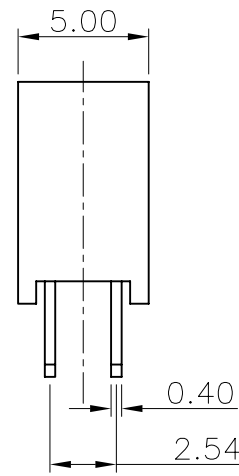

DUAL ROWS
N=No. OF CONTACTS/2

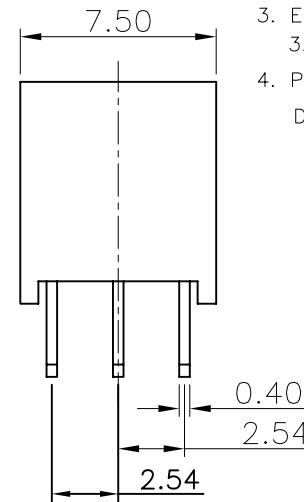

DUAL ROWS
N=No. OF CONTACTS/3

GENERAL TOLERANCE		ANGLE TOLERANCE		PROJECTION	TITLE	FEMALT HEADER PITCH	
X.	±0.60	X.	±5°	mm	2.54mm V/T SINGLE/DUAL ROWS TYPE		
.X	±0.38	.X	±3°	A4	SERIES	DS1023 SERIES	
.XX	±0.25	.XX	±2°				
DRAWING TYPE		CUSTOMER		 晨翔电子有限公司 CONNFLY CONNFLY ELECTRONIC CO. LTD			
SCALE	1:1	SHEET	1 OF 1				
DRAWING NO.	C-DS1023-XXX1-A						

REV.	DESCRIPTION	DRAWN	CHECKED	APPROVED
A	NEW RELEASE	YCH 10/22/09'	~	

NOTES:

- ELECTRICAL CHARACTERISTICS:
 - CONTACT RESISTANCE: 20mΩ Max. INITIAL.
 - DIELECTRIC WITHSTANDING VOLTAGE: 500V AC(rms) FOR 1 MINUTE.
 - INSULATION RESISTANCE: 1000MΩ Min.
- MECHANICAL CHARACTERISTICS:
 - CONTACT RETENTION FORCE: 500gf Min.
- ENVIRONMENT CHARACTERISTICS:
 - TEMPERATURE RANGE: -40°C ~ +105°C.
- PRODUCT NUMBER CODE:

DS1023- X X X X

- PROFILE HEIGHT(DIM A)
2: 5.0mm
- CONTACT PLATING
0: SELETIVE GOLD FLASH
F1: FULL GOLD FLASH
2: NICKEL + GOLD FLASH
- MOUNTING TYPE
S: Straight TYPE
- No.OF CONTACTS
1*1-1*40
2*2-2*40
3*3-3*40

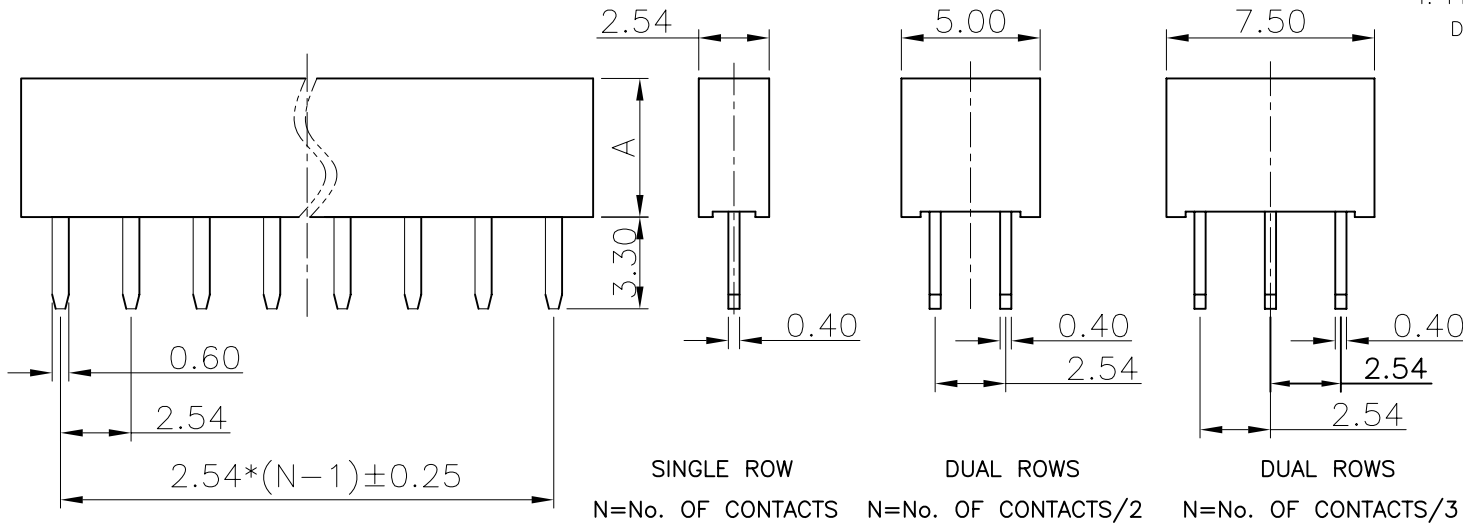
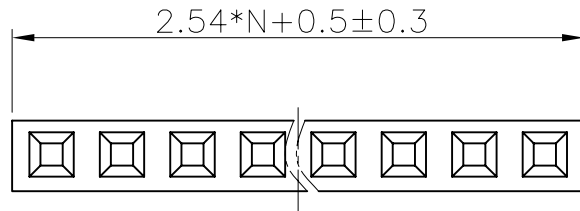

GENERAL TOLERANCE		ANGLE TOLERANCE		PROJECTION		TITLE	FEMALT HEADER PITCH
X.	±0.60	X.	±5°	UNITS	mm	2.54mm V/T SINGLE/DUAL ROWS TYPE	
.X	±0.38	.X	±3°	SHEET SIZE	A4	SERIES	DS1023 SERIES
.XX	±0.25	.XX	±2°	晨翔电子有限公司 CONNFLY CONNFLY ELECTRONIC CO. LTD			
DRAWING TYPE		ASSEMBLY					
SCALE	1:1	SHEET	1 OF 1				
DRAWING NO.		C-DS1023-XXX2-A					

REV.	DESCRIPTION	DRAWN	CHECKED	APPROVED
A	NEW RELEASE	LJH 11/11/05'		

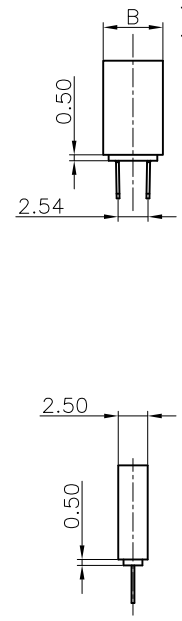
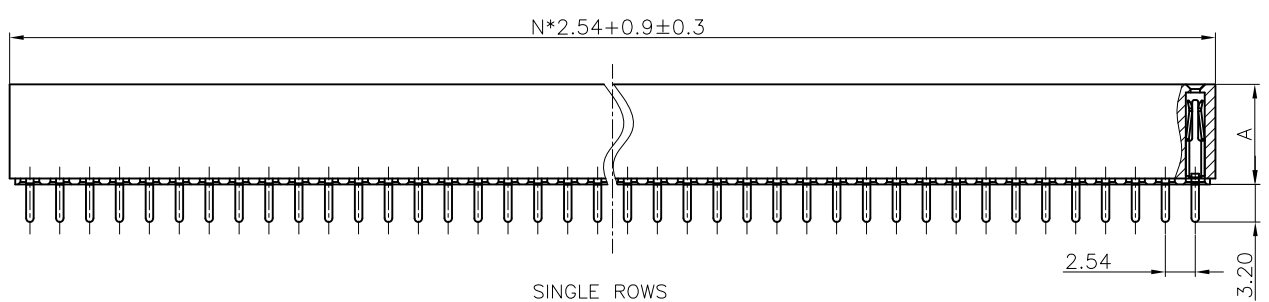
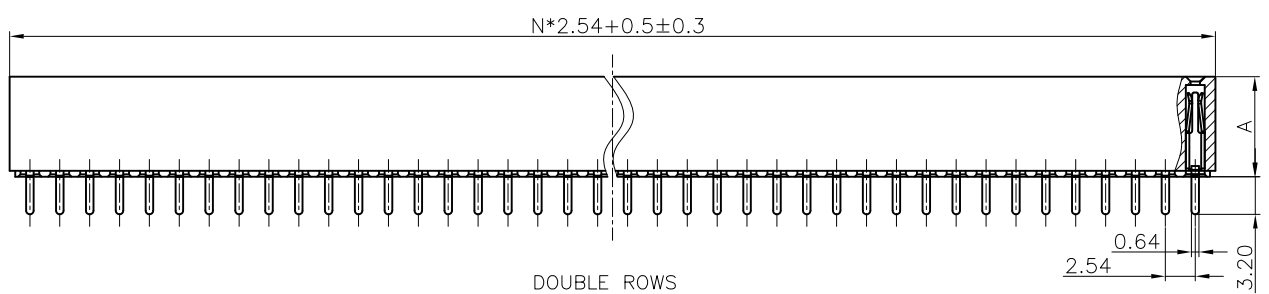
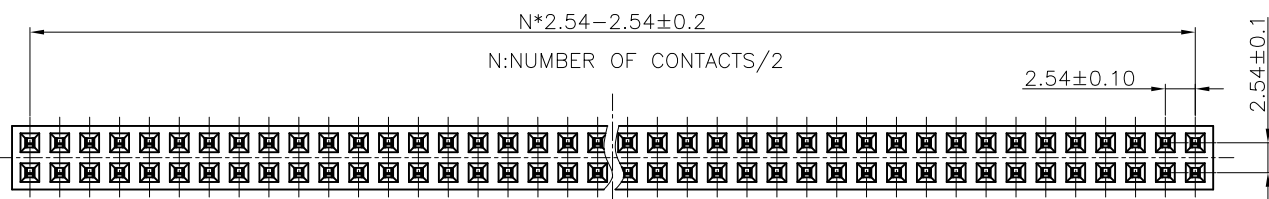

NOTES:

- MATERIAL
 - INSULATOR MATERIAL: THERMOPLASTIC (UL 94V-0).
 - CONTACT MATERIAL: COPPER ALLOY.
- SPECIFICATION
 - TEMPERATURE: -40° to $+105^\circ\text{C}$.
 - DIELECTRIC WITHSTANDING VOLTAGE: AC 500V AC.
 - INSULATION RESISTANCE: $1000\text{M}\Omega$ min.
 - CURRENT RATING: 3A.

3. PART NUMBER: DS1023-01

4. PRODUCT NUMBER CODE:

DS1023-01 - X X X X

- PROFILE HEIGHT (DIM A)
 - 1: 8.5mm
 - 2: 5.0mm
- CONTACT PLATING
 - F1: FULL GOLD FLASH
 - 0: Selective gold flash
- MOUNTING TYPE
 - S: Straight TYPE
- No. OF CONTACTS
 - 1*1 - 1*40
 - 2*2 - 2*40
- SERIES No. DS1023-01

DIM.	A	B
TYPE 1	8.50	5.40
TYPE 2	5.00	5.00

GENERAL TOLERANCE		ANGLE TOLERANCE		PROJECTION		TITLE	FEMALE HEADER PITCH	
X.	± 0.60	X.	$\pm 5^\circ$	UNITS	mm		2.54mm V/T TYPE	
.X	± 0.38	.X	$\pm 3^\circ$	SHEET SIZE	A4	SERIES	DS1023-01 SERIES	
.XX	± 0.25	.XX	$\pm 2^\circ$	晨翔电子有限公司 CONNFLY CONNFLY ELECTRONIC CO. LTD				
DRAWING TYPE		CUSTOMER						
SCALE	1:1	SHEET	1 OF 1					
DRAWING NO.		C-DS1023-01-XXXX						

REV.	DESCRIPTION	DRAWN	CHECKED	APPROVED
A	NEW RELEASE	YCH 08/28/08'	~	

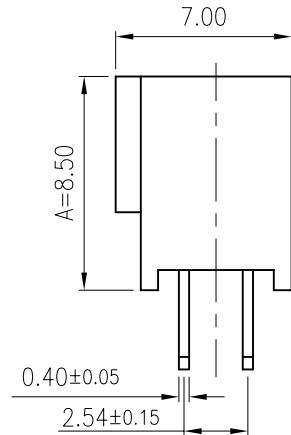
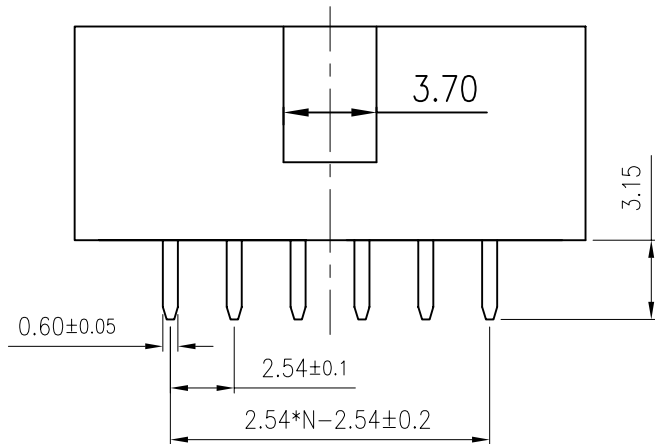
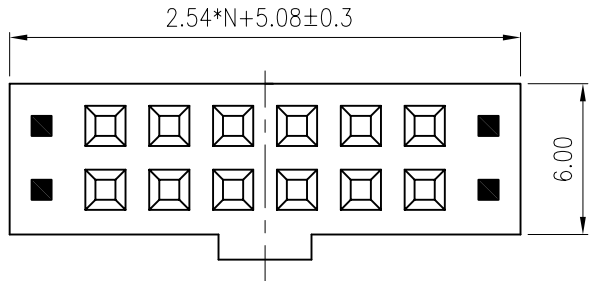

NOTES:

1. SPECIFICATION

- 1.1 TEMPERATURE: -40° to +105°C.
- 1.2 DIELECTRIC WITHSTANDING VOLTAGE: AC 500V AC.
- 1.3 INSULATION RESISTANCE: 1000MΩ
- 1.4 CURRENT RATING: 3Amps.
- 1.5 CONTACT RESISTANCE: 30mΩ.max.

2. PART NUMBER: DS1023-02

3. PRODUCT NUMBER CODE:

DS1023-02 - X X X X

PROFILE HEIGHT(DIM A)
1: 8.5mm

CONTACT PLATING
0: SELECTIVE GOLD FLASH
F1: FULL GOLD FLASH

MOUNTING TYPE
S: Straight TYPE

No.OF CONTACTS
2*2~2*40(2 rows)

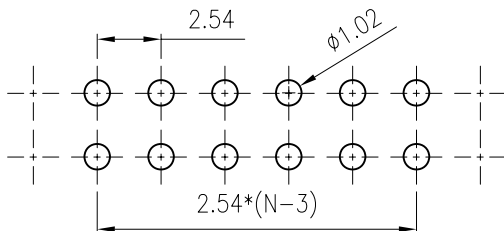

RECOMMAND PCB LAYOUT(TOLERANCE=±0.05)

GENERAL TOLERANCE		ANGLE TOLERANCE		PROJECTION		TITLE	2.54mm FEMALE HEADER FOR "BOX HEADER" MATING	
X.	±0.60	X.	±5°	UNITS	mm			
.X	±0.38	.X	±3°	SHEET SIZE	A4	SERIES	DS1023-02 SERIES	
.XX	±0.25	.XX	±2°	晨翔电子有限公司 CONNFLY CONNFLY ELECTRONIC CO. LTD				
DRAWING TYPE		CUSTOMER						
SCALE	1:1	SHEET	1 OF 1					
DRAWING NO.		C-DS1023-02-XSXX						

REV.	DESCRIPTION	DRAWN	CHECKED	APPROVED
A	NEW RELEASE	YCH 08/28/08'	~	

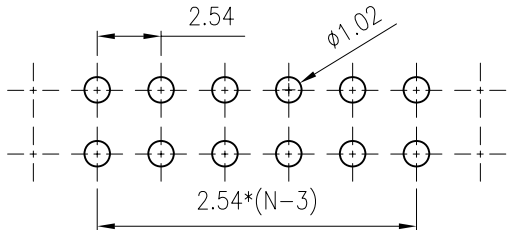
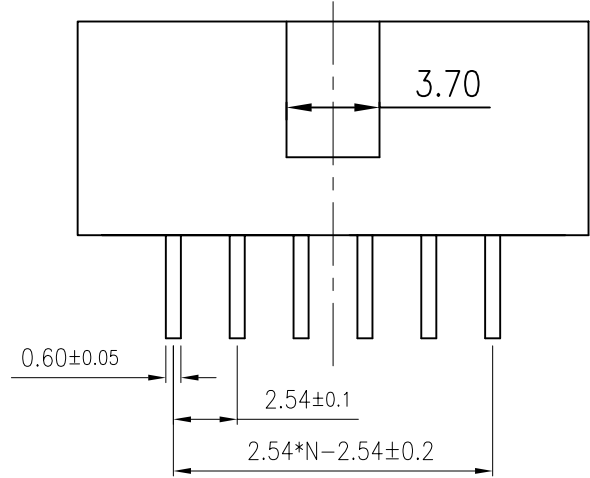
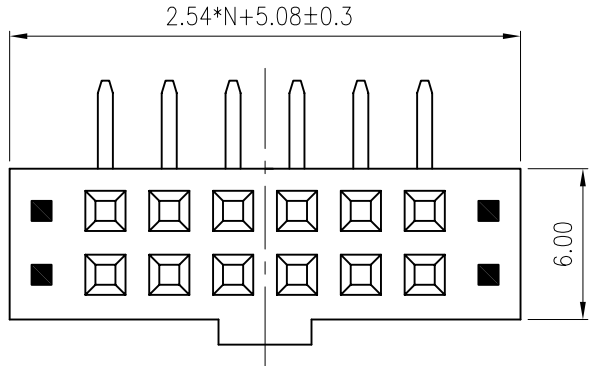

RECOMMAND PCB LAYOUT(TOLERANCE=±0.05)

NOTES:

- SPECIFICATION
 - TEMPERATURE: -40° to +105°C.
 - DIELECTRIC WITHSTANDING VOLTAGE: AC 500V AC.
 - INSULATION RESISTANCE: 1000MΩ
 - CURRENT RATING: 3Amps.
 - CONTACT RESISTANCE: 30mΩ.max.

2. PART NUMBER: DS1023-02

3. PRODUCT NUMBER CODE:

DS1023-02 - X X X X

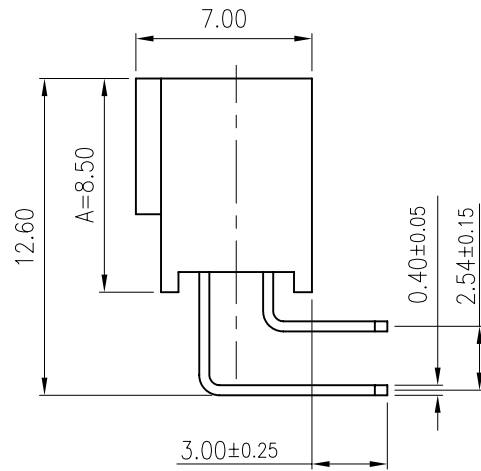

- PROFILE HEIGHT(DIM A)
1: 8.5mm
- CONTACT PLATING
0: SELECTIVE GOLD FLASH
F1: FULL GOLD FLASH
- MOUNTING TYPE
R: R/A TYPE
- No.OF CONTACTS
2*2~2*40(2 rows)

GENERAL TOLERANCE		ANGLE TOLERANCE		PROJECTION		TITLE	2.54mm FEMALE HEADER FOR "BOX HEADER" MATING	
X.	±0.60	X.	±5°	UNITS	mm			
.X	±0.38	.X	±3°	SHEET SIZE	A4	SERIES	DS1023-02 SERIES	
.XX	±0.25	.XX	±2°	晨翔电子有限公司 CONNFLY CONNFLY ELECTRONIC CO. LTD				
DRAWING TYPE		CUSTOMER						
SCALE	1:1	SHEET	1 OF 1					
DRAWING NO.		C-DS1023-02-XRXX						

REV.	DESCRIPTION	DRAWN	CHECKED	APPROVED
A	NEW RELEASE	LJH 04/09/06'	~	LJC 04/09/06'
B	增加规格	YCH 01/26/08'	~	LJC 04/09/06'
C	修改图纸错误	YCH 06/01/09'	~	

NOTES:

1. ELECTRICAL CHARACTERISTICS:

- 1.1 CONTACT RESISTANCE: 20mΩ Max.
- 1.2 DIELECTRIC WITHSTANDING VOLTAGE: 500V AC(rms) FOR 1 MINUTE.
- 1.3 INSULATION RESISTANCE: 1000MΩ Min.

2. ENVIRONMENT CHARACTERISTICS:

- 3.1 TEMPERATURE: -40°C~+105°C.

3. PRODUCT NUMBER CODE:

DS1023-03- X X X

- CONTACT PLATING
- 0: SELETIVE GOLD FLASH
- 8: FULL GOLD FLASH
- 2: NICKEL + GOLD FLASH
- MOUNTING TYPE
- V: V/T TYPE
- No.OF CONTACTS
- 1*2~1*40
- 2*2~2*40
- SERIES No.
- DS1023-03

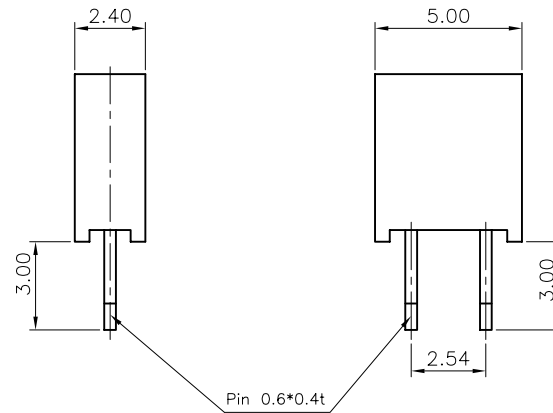
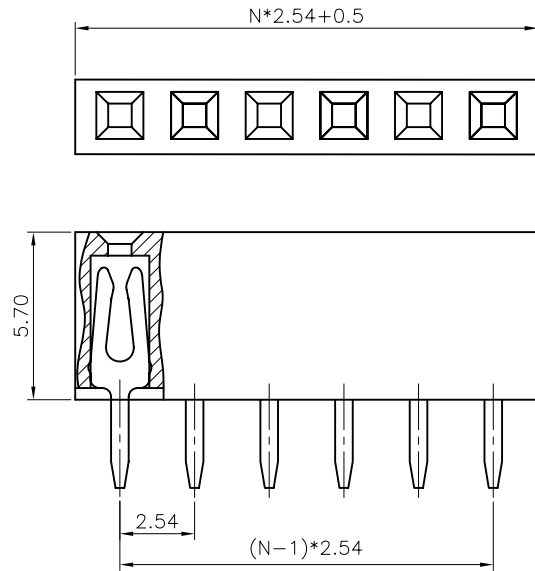

GENERAL TOLERANCE		ANGLE TOLERANCE		PROJECTION		TITLE	FEMALT HEADER PITCH		
X.	±0.60	X.	±5°	UNITS	mm	2.54mm TYPE H=5.70mm			
.X	±0.38	.X	±3°	SHEET SIZE	A4	SERIES	DS1023-03 SERIES		
.XX	±0.25	.XX	±2°	晨翔电子有限公司 CONNFLY CONNFLY ELECTRONIC CO. LTD					
DRAWING TYPE		CUSTOMER							
SCALE	1:1	SHEET	1 OF 1						
DRAWING NO.		C-DS1023-03-XXX-C							

REV.	DESCRIPTION	DRAWN	CHECKED	APPROVED
A	NEW RELEASE	y ch 01/24/08'		

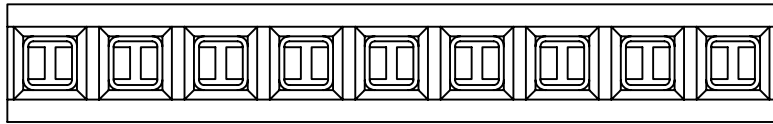

NOTES:

- MATERIAL
 - INSULATOR MATERIAL:THERMOPLASTIC(UL 94V-0).
 - CONTACT MATERIAL:COPPER ALLOY.
- SPECIFICATION
 - TEMPERATURE:-40° to +105°C.
 - DIELECTRIC WITHSTANDING VOLTAGE:AC 500V AC.
 - INSULATION RESISTANCE:1000MΩ min.
 - CONTACT RESISTACE: 20mΩ max.
 - CURRENT RATING:3A.
- PART NUMBER: DS1023-06
- PRODUCT NUMBER CODE:
DS1023-06 - X X X

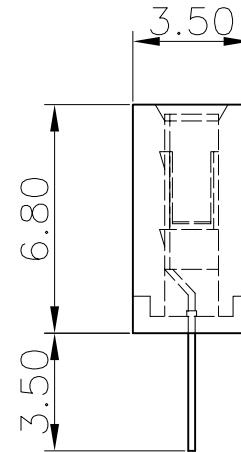

CONTACT PLATING
8: Full glod flash
0: Selective gold flash

MOUNTIING TYPE
V: V/T type

No.of Contacts
1*1 - 1*40

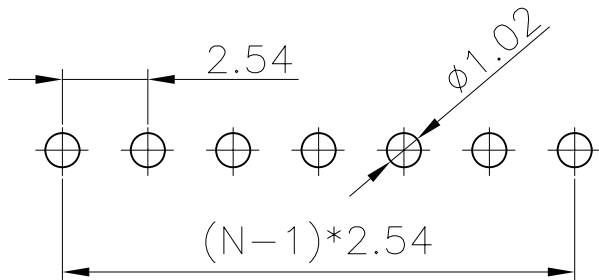
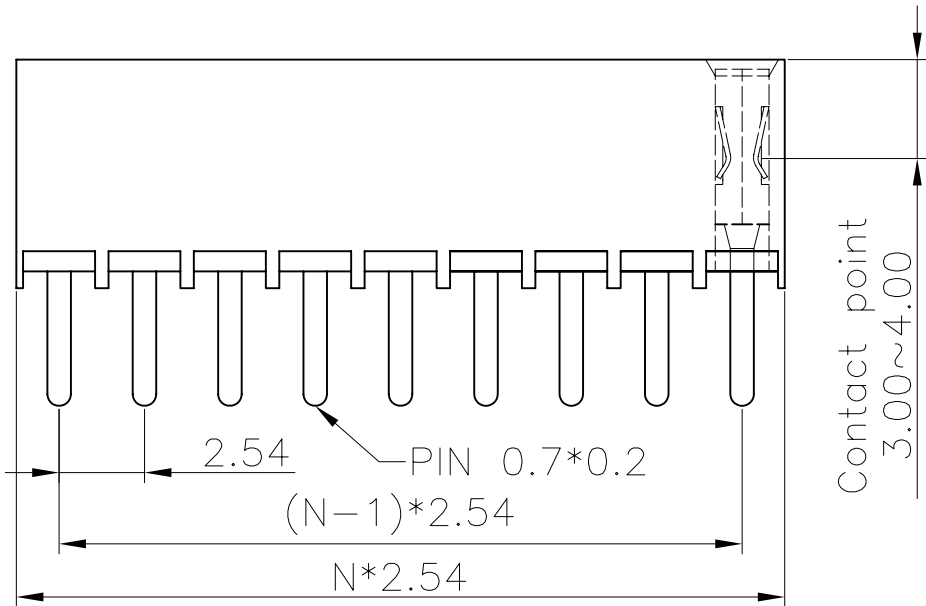

RECOMMEND PCB LAYOUT
(TOLERANCE=±0.05)

GENERAL TOLERANCE		ANGLE TOLERANCE		PROJECTION		TITLE	SINGLE ROW FEMALE HEADER
X.	±0.60	X.	±5°	UNITS	mm	PITCH 2.54mm V/T TYPE H=6.8mm	
.X	±0.38	.X	±3°	SHEET SIZE	A4	SERIES	DS1023-06 SERIES
.XX	±0.25	.XX	±2°	晨翔电子有限公司 CONNFLY CONNFLY ELECTRONIC CO. LTD			
DRAWING TYPE		CUSTOMER					
SCALE	1:1	SHEET	1 OF 1				
DRAWING NO.		C-DS1023-06-XXXX					

REV.	DESCRIPTION	DRAWN	CHECKED	APPROVED
A	NEW RELEASE	ych 01/24/08'		

NOTES:

- MATERIAL
 - INSULATOR MATERIAL:THERMOPLASTIC(UL 94V-0).
 - CONTACT MATERIAL:COPPER ALLOY.
- SPECIFICATION
 - TEMPERATURE: $-40^{\circ}\text{C}\sim+105^{\circ}\text{C}$.
 - DIELECTRIC WITHSTANDING VOLTAGE:AC 500V AC.
 - INSULATION RESISTANCE:1000M Ω min.
 - CONTACT RESISTANCE: 20m Ω max.
 - CURRENT RATING:3A.
- PART NUMBER: DS1023-08
- PRODUCT NUMBER CODE:
DS1023-08 - X X X

CONTACT PLATING
 8: Full gold flash
 0: Selective gold flash
 MOUNTING TYPE
 V: V/T type
 No.of Contacts
 1*1 - 1*40

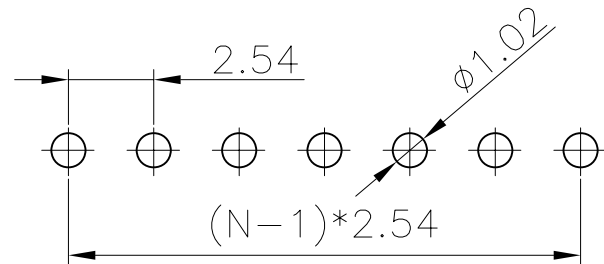
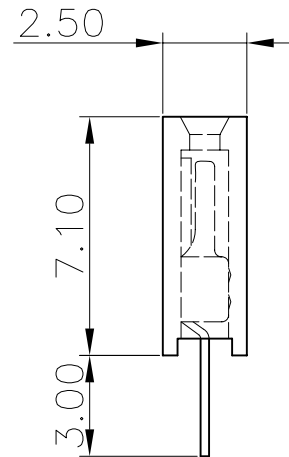
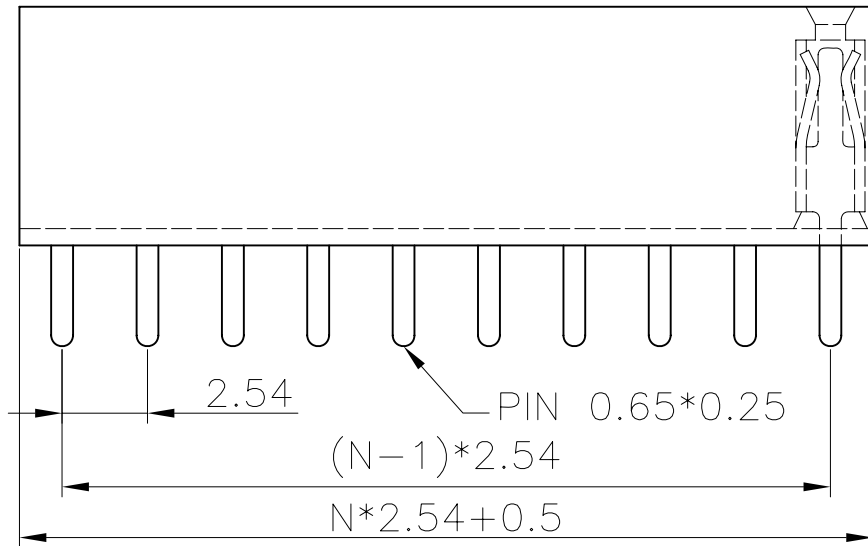
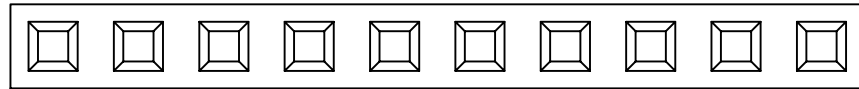

RECOMMEND PCB LAYOUT
(TOLERANCE= ± 0.05)

GENERAL TOLERANCE		ANGLE TOLERANCE		PROJECTION		TITLE	FEMALE HEADER PITCH
X.	± 0.60	X.	$\pm 5^{\circ}$	UNITS	mm		2.54mm V/T TYPE H=7.1
.X	± 0.38	.X	$\pm 3^{\circ}$	SHEET SIZE	A4	SERIES	DS1023-08 SERIES
.XX	± 0.25	.XX	$\pm 2^{\circ}$	晨翔电子有限公司 CONNFLY CONNFLY ELECTRONIC CO. LTD			
DRAWING TYPE		CUSTOMER					
SCALE	1:1	SHEET	1 OF 1				
DRAWING NO.		C-DS1023-08-XXX					

N:NUMBER OF CONTACTS/2

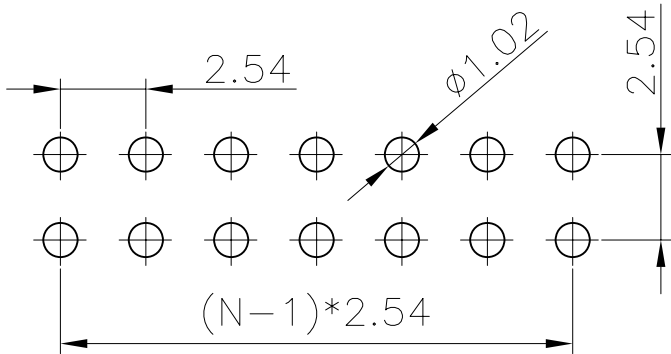
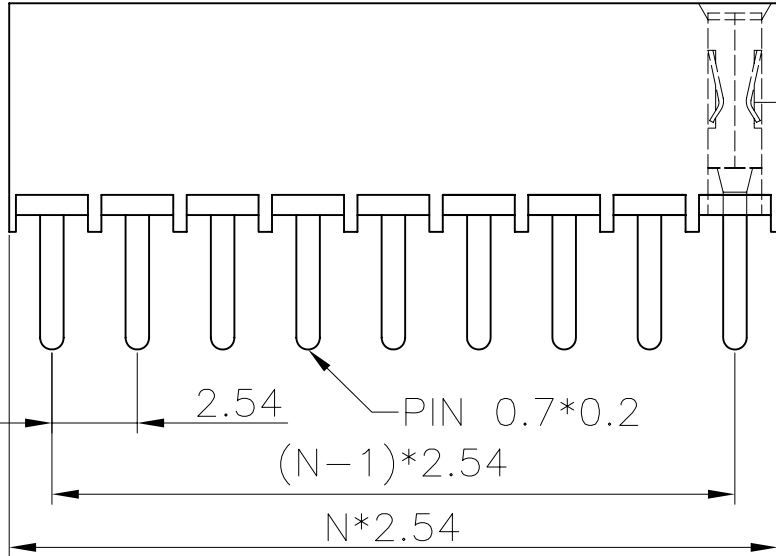
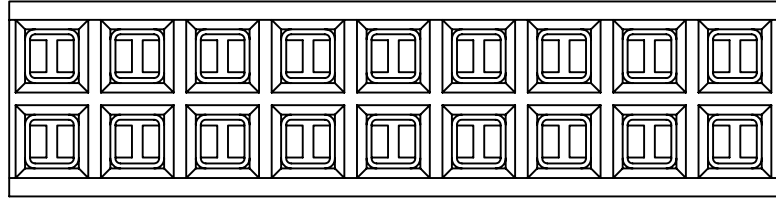

RECOMMEND PCB LAYOUT
(TOLERANCE=±0.05)

REV.	DESCRIPTION	DRAWN	CHECKED	APPROVED
A	NEW RELEASE	ych 01/24/08'		

NOTES:

- MATERIAL
 - INSULATOR MATERIAL: THERMOPLASTIC(UL 94V-0).
 - CONTACT MATERIAL: COPPER ALLOY.
- SPECIFICATION
 - TEMPERATURE: -40°C~+105°C.
 - DIELECTRIC WITHSTANDING VOLTAGE: AC 500V AC.
 - INSULATION RESISTANCE: 1000MΩ min.
 - CONTACT RESISTANCE: 20mΩ max.
 - CURRENT RATING: 3A.
- PART NUMBER: DS1023-07
- PRODUCT NUMBER CODE:
DS1023-07 - X X X

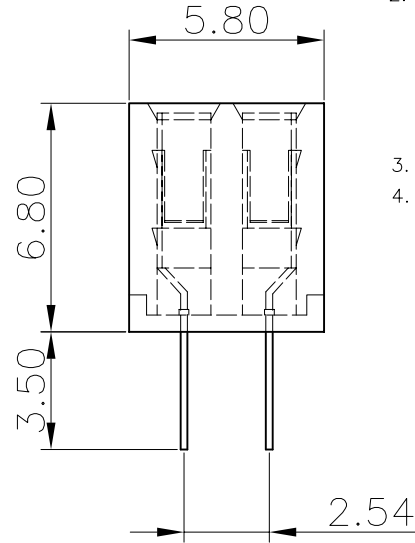

- CONTACT PLATING
8: Full gold flash
0: Selective gold flash
- MOUNTING TYPE
V: V/T type
- No. of Contacts
2*1 - 2*40

GENERAL TOLERANCE		ANGLE TOLERANCE		PROJECTION		TITLE	FEMALE HEADER PITCH
X.	±0.60	X.	±5°	UNITS	mm		2.54mm V/T TYPE h=6.8mm
.X	±0.38	.X	±3°	SHEET SIZE	A4	SERIES	DS1023-07 SERIES
.XX	±0.25	.XX	±2°	晨翔电子有限公司 CONNFLY CONNFLY ELECTRONIC CO. LTD			
DRAWING TYPE		CUSTOMER					
SCALE	1:1	SHEET	1 OF 1				
DRAWING NO.		C-DS1023-07-XXXX					

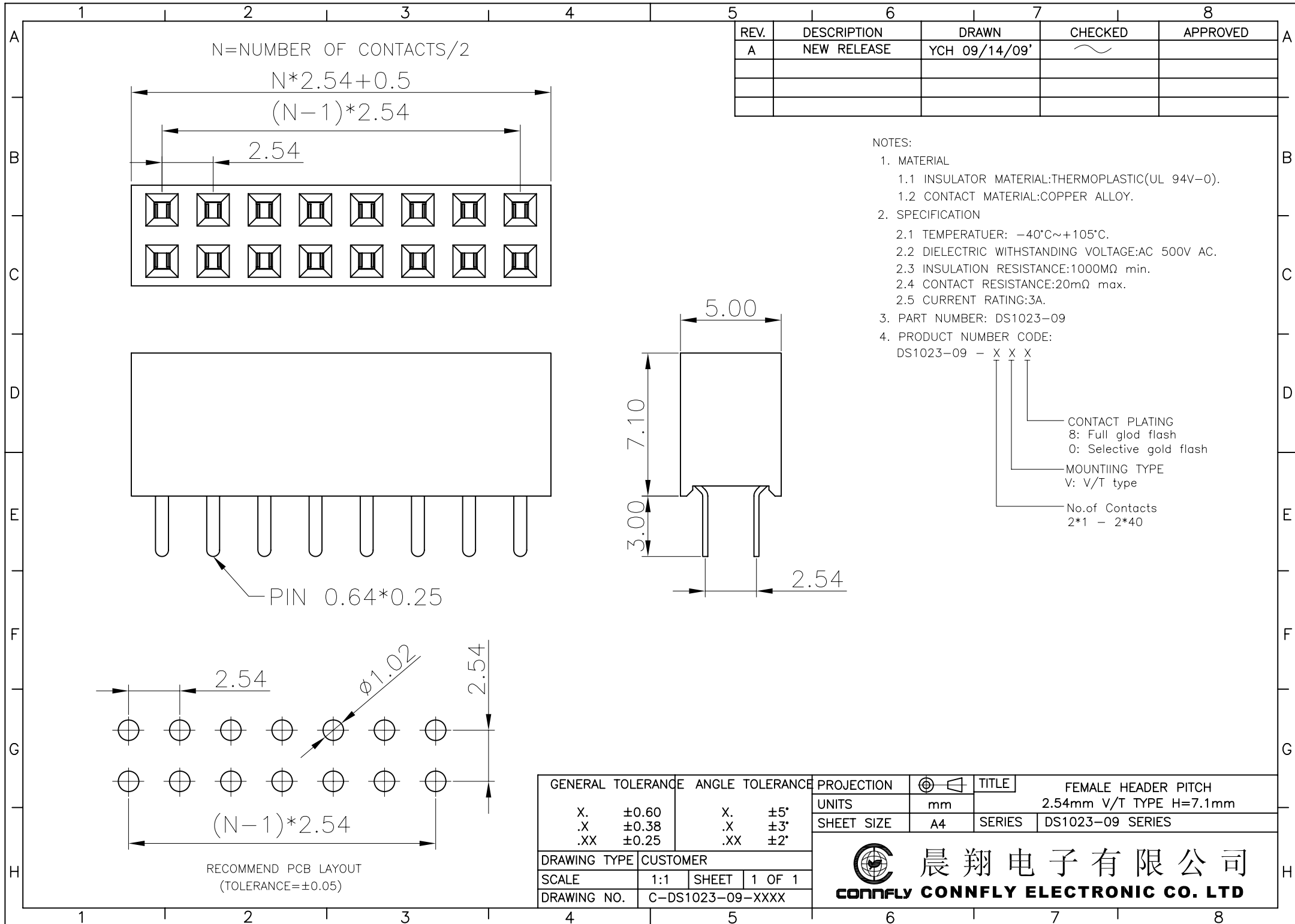

REV.	DESCRIPTION	DRAWN	CHECKED	APPROVED
A	NEW RELEASE	YCH 09/14/09'		

GENERAL TOLERANCE		ANGLE TOLERANCE		PROJECTION		TITLE	FEMALE HEADER PITCH
X.	±0.60	X.	±5°	UNITS	mm	2.54mm V/T TYPE H=7.1mm	
.X	±0.38	.X	±3°	SHEET SIZE	A4	SERIES	DS1023-09 SERIES
.XX	±0.25	.XX	±2°	晨翔电子有限公司 CONNFLY CONNFLY ELECTRONIC CO. LTD			
DRAWING TYPE		CUSTOMER					
SCALE	1:1	SHEET	1 OF 1				
DRAWING NO.		C-DS1023-09-XXXX					

REV.	DESCRIPTION	DRAWN	CHECKED	APPROVED
A	NEW RELEASE	ych 01/24/08'		

NOTES:

- MATERIAL
 - INSULATOR MATERIAL:THERMOPLASTIC(UL 94V-0).
 - CONTACT MATERIAL:COPPER ALLOY.
- SPECIFICATION
 - TEMPERATURE:-40° to +105°C.
 - DIELECTRIC WITHSTANDING VOLTAGE:AC 500V AC.
 - INSULATION RESISTANCE:1000MΩ min.
 - CONTACT RESISTANCE:20mΩ max.
 - CURRENT RATING:3A.

3. PART NUMBER: DS1023-12

4. PRODUCT NUMBER CODE:

DS1023-12 - X X X

- CONTACT PLATING
 - 8: Full gold flash
 - 0: Selective gold flash
- MOUNTING TYPE
 - V: V/T type
- No. of Contacts
 - 1*1 - 1*40

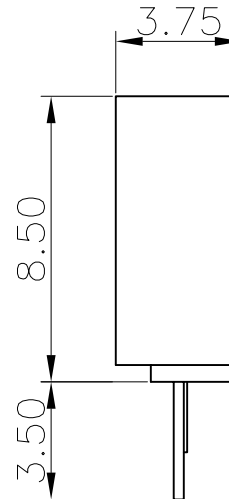
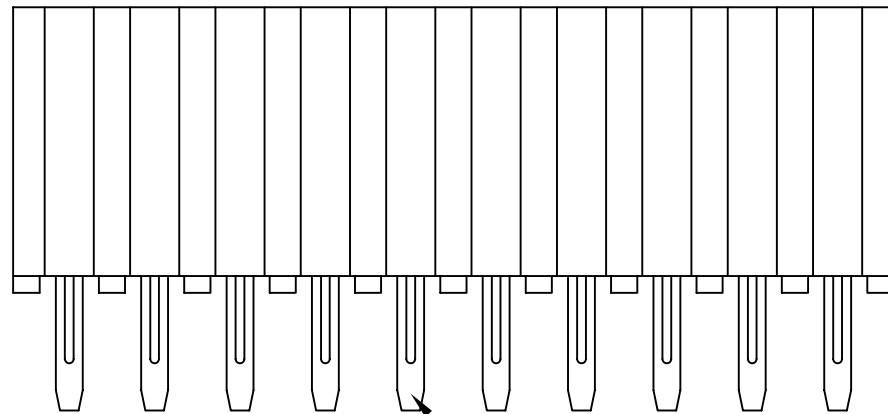
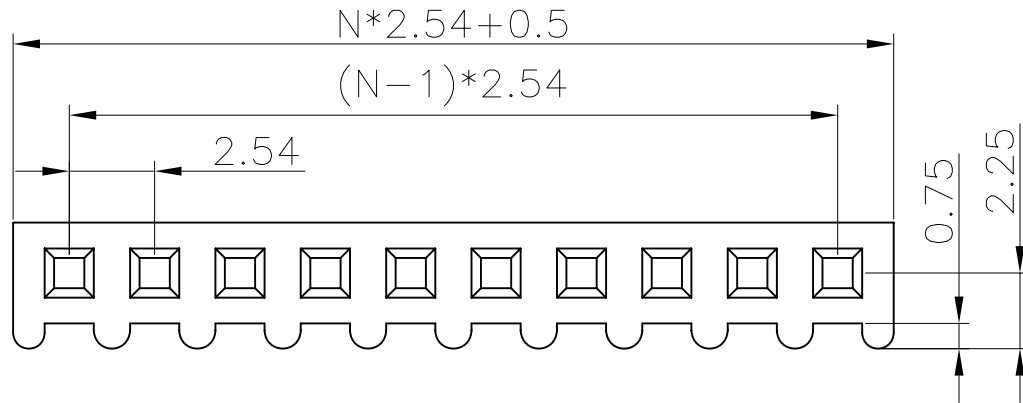

PIN 0.80*0.30

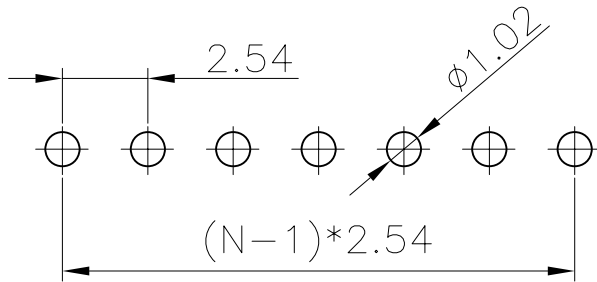

RECOMMEND PCB LAYOUT
(TOLERANCE=±0.05)

GENERAL TOLERANCE		ANGLE TOLERANCE		PROJECTION		TITLE	FEMALE HEADER PITCH
X.	±0.60	X.	±5°	UNITS	mm		2.54mm V/T TYPE H=8.5mm
.X	±0.38	.X	±3°	SHEET SIZE	A4	SERIES	DS1023-12 SERIES
.XX	±0.25	.XX	±2°	晨翔电子有限公司 CONNFLY CONNFLY ELECTRONIC CO. LTD			
DRAWING TYPE		CUSTOMER					
SCALE	1:1	SHEET	1 OF 1				
DRAWING NO.		C-DS1023-12-XXX					

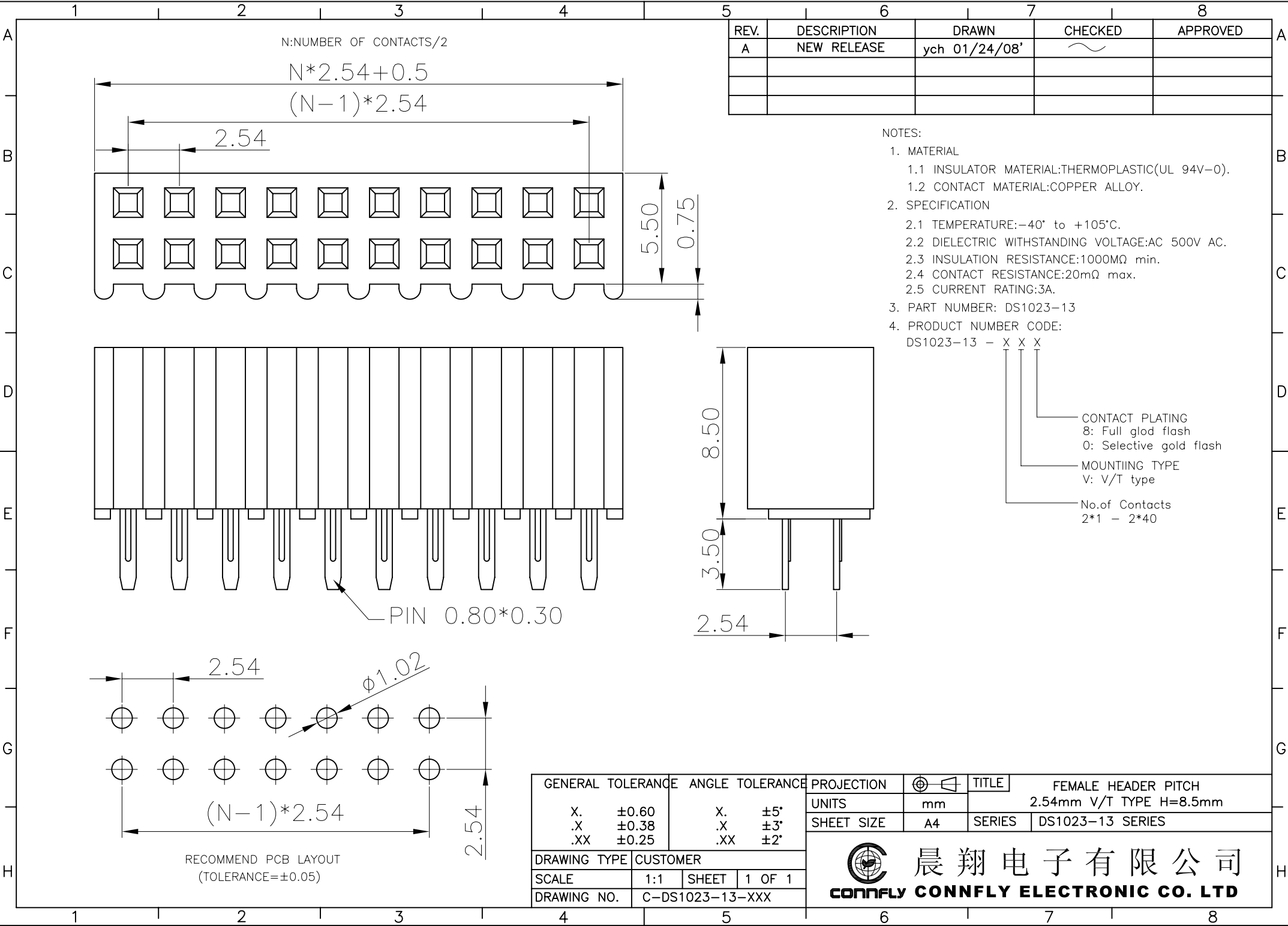

N:NUMBER OF CONTACTS/2

$$N \times 2.54 + 0.5$$

$$(N - 1) \times 2.54$$

2.54

5.50
0.75

PIN 0.80*0.30

2.54

$\phi 1.02$

$$(N - 1) \times 2.54$$

RECOMMEND PCB LAYOUT
(TOLERANCE= ± 0.05)

2.54

REV.	DESCRIPTION	DRAWN	CHECKED	APPROVED
A	NEW RELEASE	ych 01/24/08'		

NOTES:

- MATERIAL
 - INSULATOR MATERIAL:THERMOPLASTIC(UL 94V-0).
 - CONTACT MATERIAL:COPPER ALLOY.
- SPECIFICATION
 - TEMPERATURE: -40° to $+105^{\circ}$ C.
 - DIELECTRIC WITHSTANDING VOLTAGE:AC 500V AC.
 - INSULATION RESISTANCE:1000M Ω min.
 - CONTACT RESISTANCE:20m Ω max.
 - CURRENT RATING:3A.
- PART NUMBER: DS1023-13
- PRODUCT NUMBER CODE:
DS1023-13 - X X X

CONTACT PLATING
8: Full gold flash
0: Selective gold flash

MOUNTING TYPE
V: V/T type

No.of Contacts
2*1 - 2*40

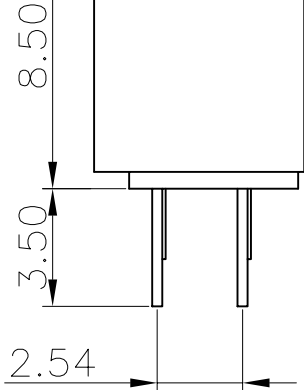

GENERAL TOLERANCE		ANGLE TOLERANCE		PROJECTION		TITLE	FEMALE HEADER PITCH
X.	± 0.60	X.	$\pm 5^{\circ}$	UNITS	mm	2.54mm V/T TYPE H=8.5mm	
.X	± 0.38	.X	$\pm 3^{\circ}$	SHEET SIZE	A4	SERIES	DS1023-13 SERIES
.XX	± 0.25	.XX	$\pm 2^{\circ}$	晨翔电子有限公司 CONNFLY CONNFLY ELECTRONIC CO. LTD			
DRAWING TYPE		CUSTOMER					
SCALE	1:1	SHEET	1 OF 1				
DRAWING NO.		C-DS1023-13-XXX					

REV.	DESCRIPTION	DRAWN	CHECKED	APPROVED
A	NEW RELEASE	YCH 09/16/10'	~	

N=NUMBER OF CONTACTS

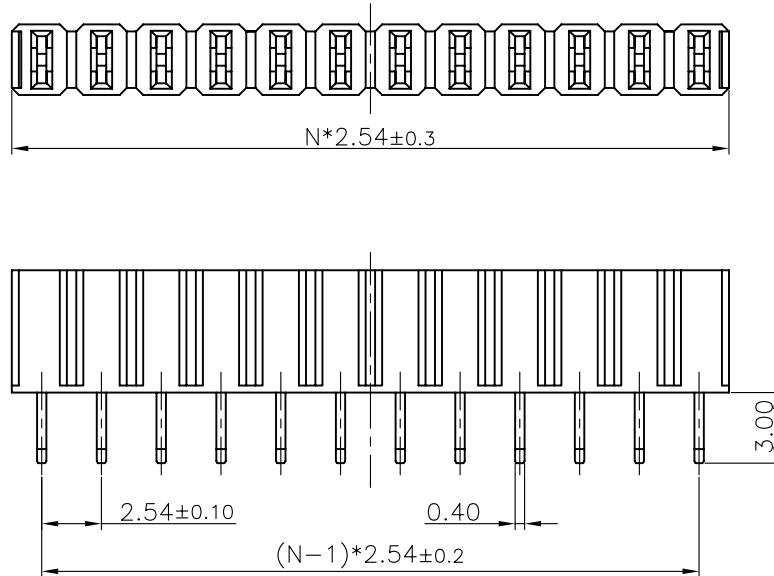

NOTES:

- MATERIAL
 - INSULATOR MATERIAL:THERMOPLASTIC(UL 94V-0).
 - CONTACT MATERIAL:COPPER ALLOY.
- SPECIFICATION
 - TEMPERATURE:-40° to +105°C.
 - DIELECTRIC WITHSTANDING VOLTAGE:AC 500V AC.
 - INSULATION RESISTANCE:1000MΩ min.
 - CONTACT RESISTANCE:20mΩ max.
 - CURRENT RATING:3A.

3. PART NUMBER: DS1023-19

4. PRODUCT NUMBER CODE:

DS1023-19 - X X X

CONTACT PLATING
8: FULL GOLD FLASH
0: Selective gold flash

MOUNTING TYPE
V: V/T TYPE

ROWS
1*1 - 1*40

SERIES No.
DS1023-19

GENERAL TOLERANCE		ANGLE TOLERANCE		PROJECTION		TITLE	SINGLE ROW FEMALE HEADER PITCH	
X.	±0.60	X.	±5°	UNITS	mm	2.54mm V/T TYPE H=5.2mm		
.X	±0.38	.X	±3°	SHEET SIZE	A4	SERIES	DS1023-19 SERIES	
.XX	±0.25	.XX	±2°	晨翔电子有限公司 CONNFLY CONNFLY ELECTRONIC CO. LTD				
DRAWING TYPE		CUSTOMER						
SCALE	1:1	SHEET	1 OF 1					
DRAWING NO.	C-DS1023-19-XXX							

REV.	DESCRIPTION	DRAWN	CHECKED	APPROVED
A	NEW RELEASE	YCH 12/07/07'	~	

N:NUMBER OF CONTACTS/2

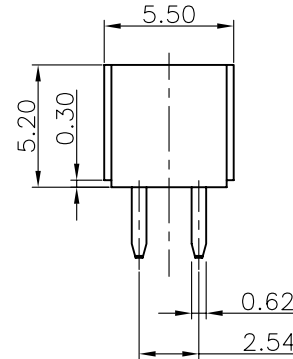
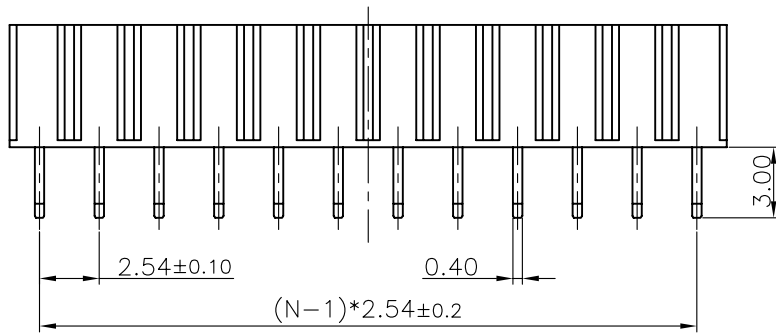
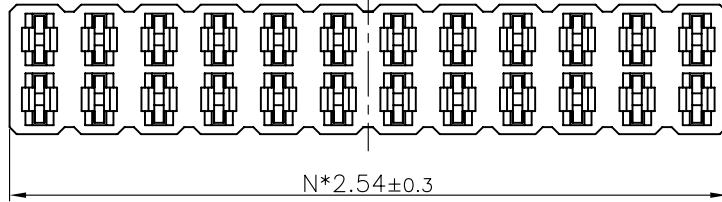

NOTES:

- MATERIAL
 - INSULATOR MATERIAL:THERMOPLASTIC(UL 94V-0).
 - CONTACT MATERIAL:COPPER ALLOY.
- SPECIFICATION
 - TEMPERATURE:-40° to +105°C.
 - DIELECTRIC WITHSTANDING VOLTAGE:AC 500V AC.
 - INSULATION RESISTANCE:1000MΩ min.
 - CONTACT RESISTANCE:20mΩ max.
 - CURRENT RATING:3A.

3. PART NUMBER: DS1023-20

4. PRODUCT NUMBER CODE:

DS1023-20 - X X X

CONTACT PLATING
8: FULL GOLD FLASH
0: Selective gold flash

MOUNTING TYPE
V: V/T TYPE

ROWS
2*2 - 2*40

SERIES No.
DS1023-20

GENERAL TOLERANCE	ANGLE TOLERANCE	PROJECTION		TITLE	2 ROWS FEMALE HEADER PITCH
X. ±0.60	X. ±5°	UNITS	mm		2.54mm V/T TYPE H=5.2mm
.X ±0.38	.X ±3°	SHEET SIZE	A4	SERIES	DS1023-20 SERIES
.XX ±0.25	.XX ±2°				

DRAWING TYPE	CUSTOMER		
SCALE	1:1	SHEET	1 OF 1
DRAWING NO.	C-DS1023-20-XXX		



晨翔电子有限公司
CONNFLY CONNFLY ELECTRONIC CO. LTD

REV.	DESCRIPTION	DRAWN	CHECKED	APPROVED
A	NEW RELEASE	LJC 11/20/07'		

N:NUMBER OF CONTACTS

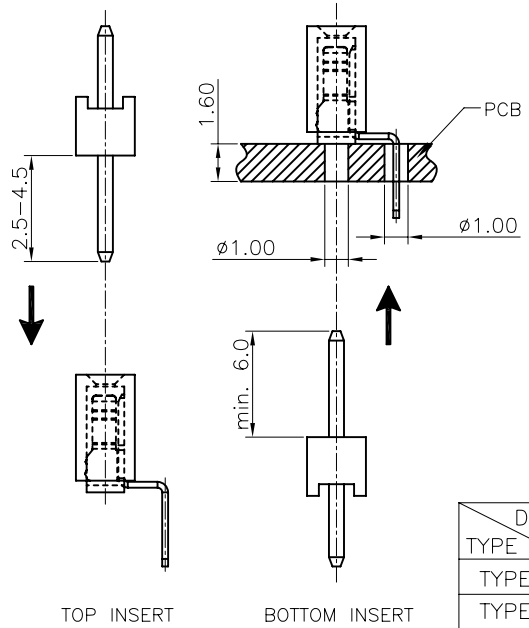
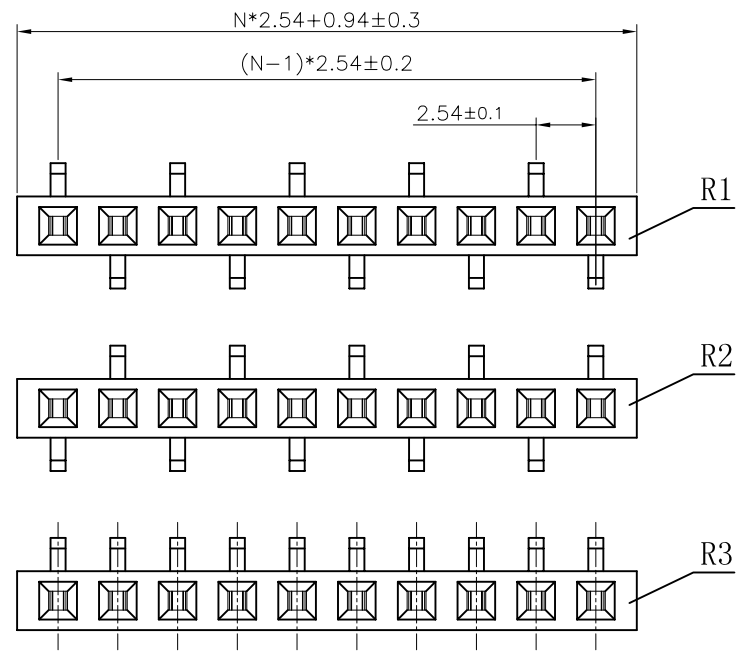

- NOTES:
- MATERIAL
 - 1.1 INSULATOR MATERIAL:THERMOPLASTIC(UL 94V-0).
 - 1.2 CONTACT MATERIAL:COPPER ALLOY.
 - SPECIFICATION
 - 2.1 TEMPERATURE:-40° to +105°C.
 - 2.2 DIELECTRIC WITHSTANDING VOLTAGE:AC 500V AC.
 - 2.3 INSULATION RESISTANCE:1000MΩ min.
 - 2.4 CURRENT RATING:3A.
 - 2.5 CONTACT RESISTANCE:20mΩ MAXIMUM.
 - PRODUCT NUMBER CODE:
 - DS1024-04 - X X X X X
 - BEND TYPE
 - 1: R1 TYPE
 - 2: R2 TYPE
 - 3: R3 TYPE
 - PROFILE HEIGHT(DIM A)
 - 1: 8.5mm
 - 2: 5.0mm
 - CONTACT PLATING
 - 8: FULL GOLD FLASH
 - 0: Selective gold flash
 - MOUNTING TYPE
 - V: V/T TYPE
 - No. OF POSITIONS
 - 1*1 - 1*40

DIM. TYPE	A
TYPE 1	8.50
TYPE 2	5.00

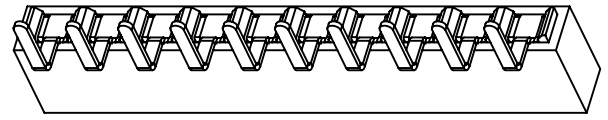
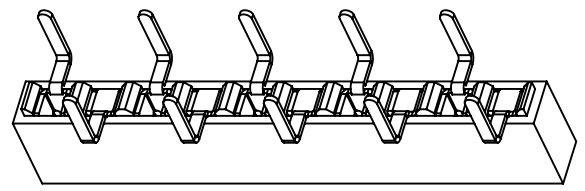
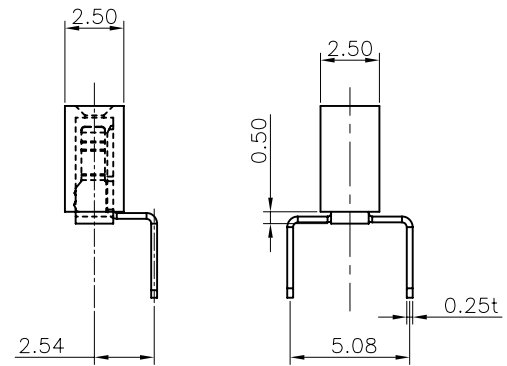
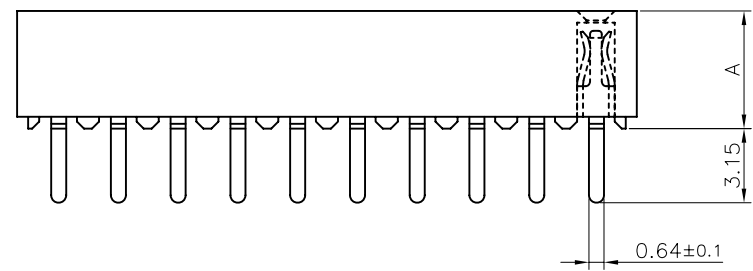

GENERAL TOLERANCE		ANGLE TOLERANCE		PROJECTION		TITLE	FEMALE HEADER PITCH
X.	±0.60	X.	±5°	UNITS	mm		2.54mm V/T TYPE DUAL ENTRY
.X	±0.38	.X	±3°	SHEET SIZE	A4	SERIES	DS1024-04 SERIES
.XX	±0.25	.XX	±2°				
DRAWING TYPE		CUSTOMER		晨翔电子有限公司 CONNFLY ELECTRONIC CO. LTD			
SCALE	1:1	SHEET	1 OF 1				
DRAWING NO.	C-DS1024-04-XXXXX						

REV.	DESCRIPTION	DRAWN	CHECKED	APPROVED
A	NEW RELEASE	YCH 11/20/07'	~	LJC 11/20/07'
B	整理图面	YCH 07/08/08'	~	LJC 03/25/09'
C	去除单排	YCH 03/25/09'	~	

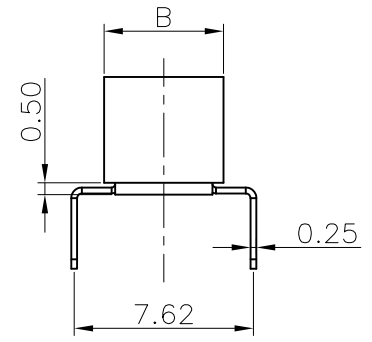
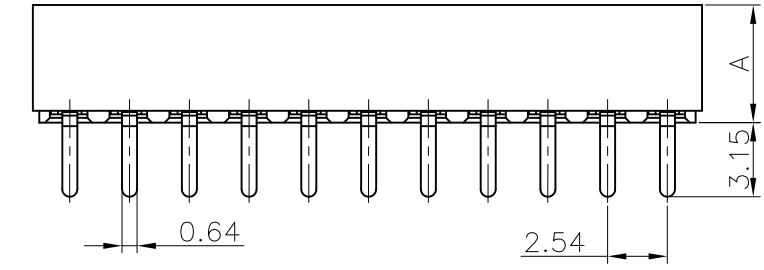
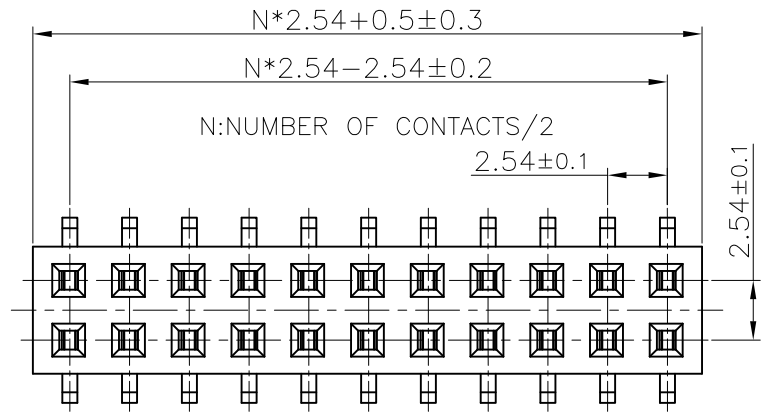

NOTES:

- MATERIAL
 - INSULATOR MATERIAL:THERMOPLASTIC(UL 94V-0).
 - CONTACT MATERIAL:COPPER ALLOY.
- SPECIFICATION
 - TEMPERATURE:-40° to +105°C.
 - DIELECTRIC WITHSTANDING VOLTAGE:AC 500V AC.
 - INSULATION RESISTANCE:1000MΩ min.
 - CURRENT RATING:3A.
- PART NUMBER: DS1024-01
- PRODUCT NUMBER CODE:
DS1024-01 - X X X X

- PROFILE HEIGHT(DIM A)
1: 8.5mm
2: 5.0mm
- CONTACT PLATING
8: FULL GOLD FLASH
0: Selective gold flash
- MOUNTING TYPE
V: Straight TYPE
- ROWS
2*2 - 2*40

DIM.	A	B
TYPE 1	8.50	5.40
TYPE 2	5.00	5.00

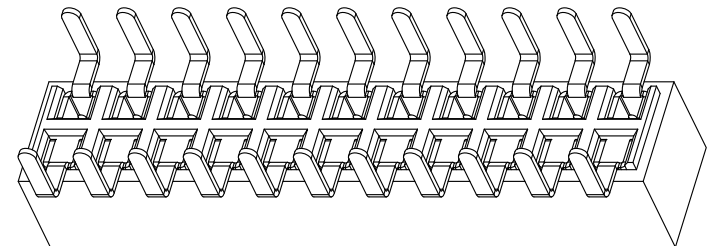

GENERAL TOLERANCE		ANGLE TOLERANCE	
X.	±0.60	X.	±5°
.X	±0.38	.X	±3°
.XX	±0.25	.XX	±2°

PROJECTION	TITLE
mm	2.54mm FEMALE HEADER
A4	BOTTOM ENTRY TYPE H=8.5/5.0mm
SERIES	DS1024-01 SERIES

DRAWING TYPE	CUSTOMER
SCALE	1:1 SHEET 1 OF 1
DRAWING NO.	C-DS1024-01-XXXX

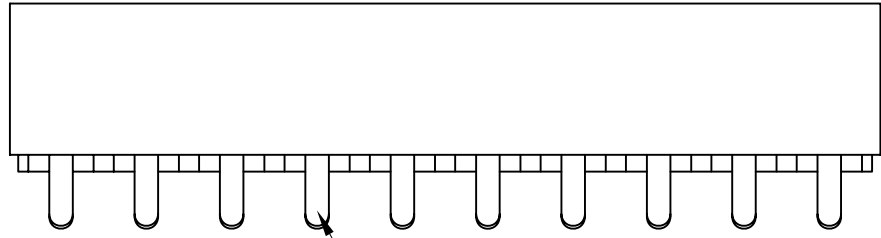
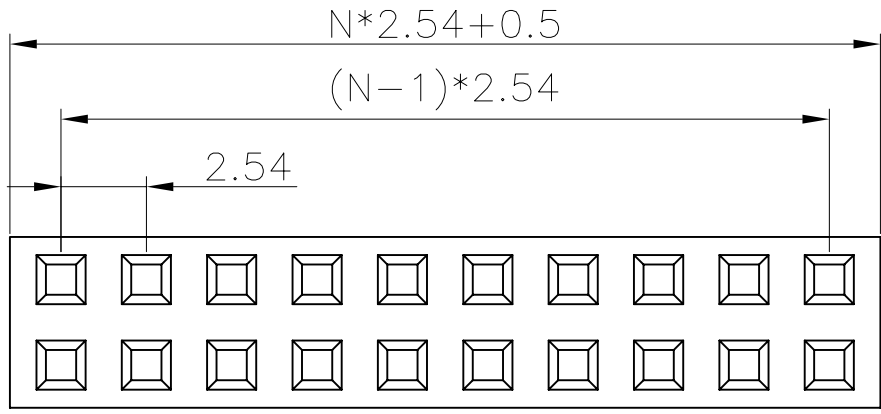

晨翔电子有限公司
CONNFLY CONNFLY ELECTRONIC CO. LTD

REV.	DESCRIPTION	DRAWN	CHECKED	APPROVED
A	NEW RELEASE	ych 01/24/08'		

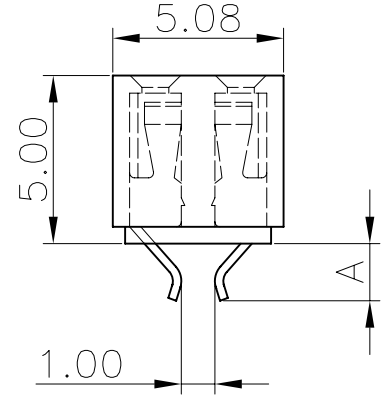

PIN 0.70*0.25

- NOTES:
- MATERIAL
 - INSULATOR MATERIAL:THERMOPLASTIC(UL 94V-0).
 - CONTACT MATERIAL:COPPER ALLOY.
 - SPECIFICATION
 - TEMPERATURE:-40' to +105'C.
 - DIELECTRIC WITHSTANDING VOLTAGE:AC 500V AC.
 - INSULATION RESISTANCE:1000MΩ min.
 - CONTACT RESISTANCE:20mΩ max.
 - CURRENT RATING:3A.
 - PART NUMBER: DS1023-14
 - PRODUCT NUMBER CODE:
DS1023-14 - X X X X



- DIM A TYPE
 - 1: 1.70 mm
 - 2: 1.00 mm
- CONTACT PLATING
 - 8: Full gold flash
 - 0: Selective gold flash
- MOUNTING TYPE
 - B: Clip Board type
- No.of Contacts
 - 1*1 - 1*40

GENERAL TOLERANCE		ANGLE TOLERANCE		PROJECTION		TITLE	FEMALE HEADER PITCH 2.54mm
X.	±0.60	X.	±5°	UNITS	mm	STRADDLE TYPE	
.X	±0.38	.X	±3°	SHEET SIZE	A4	SERIES	DS1023-14 SERIES
.XX	±0.25	.XX	±2°	 晨翔电子有限公司 CONNFLY CONNFLY ELECTRONIC CO. LTD			
DRAWING TYPE		CUSTOMER					
SCALE	1:1	SHEET	1 OF 1				
DRAWING NO.		C-DS1023-14-XXXX					

REV.	DESCRIPTION	DRAWN	CHECKED	APPROVED
A	NEW RELEASE	YCH 11/09/08'		

NOTES:

- ELECTRICAL CHARACTERISTICS:
 - CONTACT RESISTANCE: 30mΩ Max. INITIAL.
 - DIELECTRIC WITHSTANDING VOLTAGE: 500V AC(rms) FOR 1 MINUTE.
 - INSULATION RESISTANCE: 1000MΩ Min.
- ENVIRONMENT CHARACTERISTICS:
 - TEMPERATURE RANGE: -40°C~+105°C.
- PRODUCT NUMBER CODE:

DS1023-18- X X X

CONTACT PLATING
 8: FULL GOLD FLASH
 0: SECLECTIVE GOLD FLASH

MOUNTIING TYPE
 V: V/T TYPE

No.OF CONTACTS
 2*2-2*40

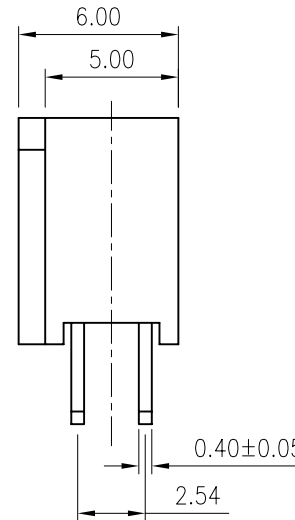
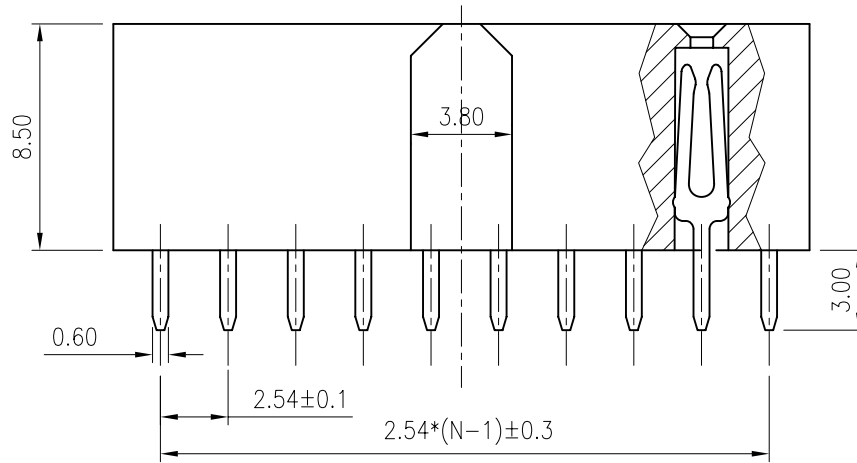
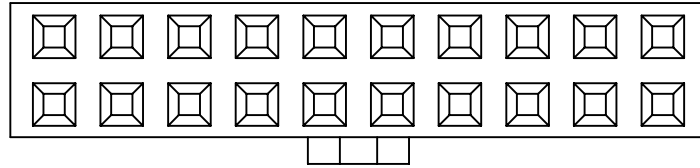

DUAL ROWS
 N:NUMBER OF CONTACTS/2

GENERAL TOLERANCE		ANGLE TOLERANCE		PROJECTION		TITLE	FEMALE HEADER PITCH 2.54mm	
X.	±0.60	X.	±5°	UNITS	mm		W/ POLARIZATION	
.X	±0.38	.X	±3°	SHEET SIZE	A4	SERIES	DS1023-18 SERIES	
.XX	±0.25	.XX	±2°			 晨翔电子有限公司 CONNFLY CONNFLY ELECTRONIC CO. LTD		
DRAWING TYPE		CUSTOMER						
SCALE	1:1	SHEET	1 OF 1					
DRAWING NO.		C-DS1023-18-XXX						

REV.	DESCRIPTION	DRAWN	CHECKED	APPROVED
A	NEW RELEASE	LJH 09/25/05'		LJC 09/25/05'
B	长端子非针尾宽度0.6更改为0.8	LL 11/29/06'		

NOTES:

- ELECTRICAL CHARACTERISTICS:
 - CONTACT RESISTANCE: 30mΩ Max. INITIAL.
 - DIELECTRIC WITHSTANDING VOLTAGE: 500V AC(rms) FOR 1 MINUTE.
 - INSULATION RESISTANCE: 1000MΩ Min.
- ENVIRONMENT CHARACTERISTICS:
 - TEMPERATURE: -40°C~+105°C.
- PRODUCT NUMBER CODE:

DS1024- X X X

- CONTACT PLATING
F1: FULL GOLD FLASH
O: SELECTIVE GOLD FLASH
- MOUNTIING TYPE
R: R/A TYPE
- No.OF CONTACTS
1*1-1*40
2*2-2*40

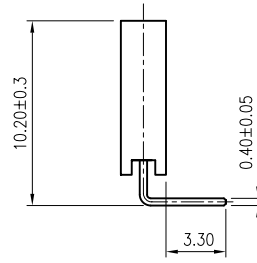
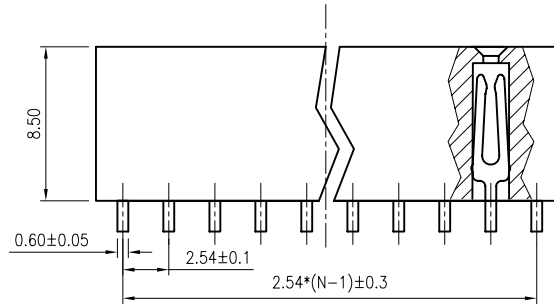
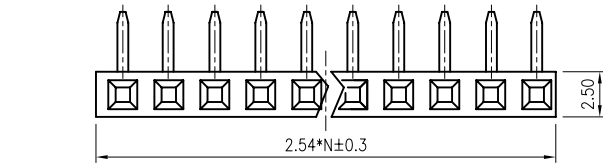

SINGLE ROW
N:NUMBER OF CONTACTS

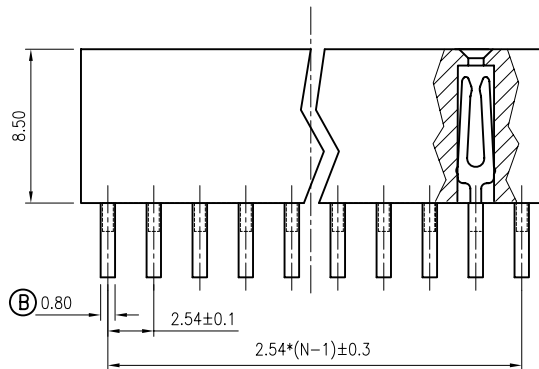
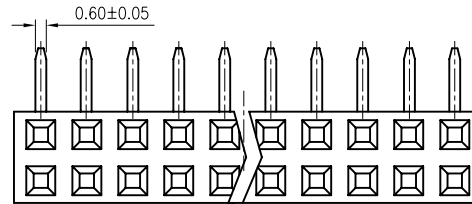

DUAL ROWS
N:NUMBER OF CONTACTS/2

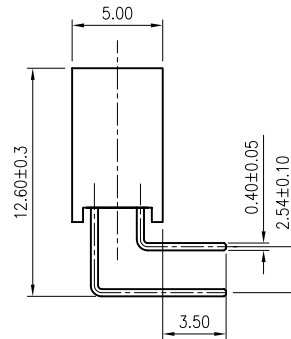

GENERAL TOLERANCE		ANGLE TOLERANCE		PROJECTION	TITLE
X.	±0.60	X.	±5°		FEMALE HEADER PITCH 2.54MM R/A TYPE
.X	±0.38	.X	±3°	mm	
.XX	±0.25	.XX	±2°	SHEET SIZE	A4 SERIES DS1024 SERIES
DRAWING TYPE	CUSTOMER			晨翔电子有限公司 CONNFLY CONNFLY ELECTRONIC CO. LTD	
SCALE	1:1	SHEET	1 OF 1		
DRAWING NO.	C-DS1024-XXXX				

REV.	DESCRIPTION	DRAWN	CHECKED	APPROVED
A	NEW RELEASE	ych 01/24/08'		

NOTES:

- MATERIAL
 - INSULATOR MATERIAL:THERMOPLASTIC(UL 94V-0).
 - CONTACT MATERIAL:COPPER ALLOY.
- SPECIFICATION
 - TEMPERATURE:-40 to +105°C.
 - DIELECTRIC WITHSTANDING VOLTAGE:AC 500V AC.
 - INSULATION RESISTANCE:1000MΩ min.
 - CONTACT RESISTANCE:20mΩ max.
 - CURRENT RATING:3A.
- PRODUCT NUMBER CODE:
DS1024-02 - X X X

CONTACT PLATING
8: Full gold flash
0: Selective gold flash

MOUNTING TYPE
R: R/A type

No.of Contacts
1*1 - 1*40

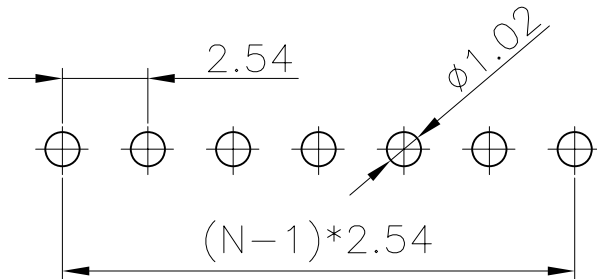
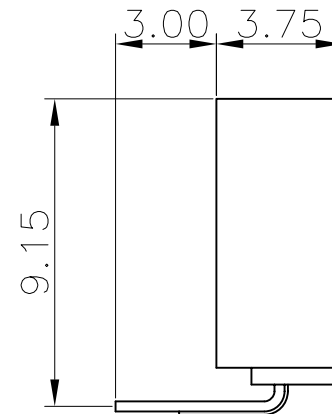
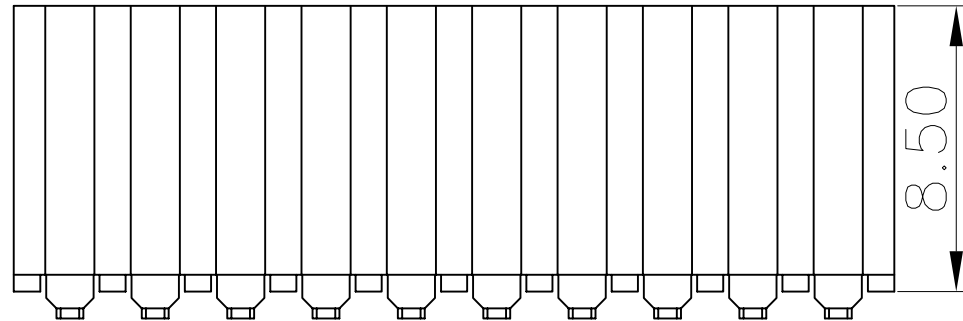
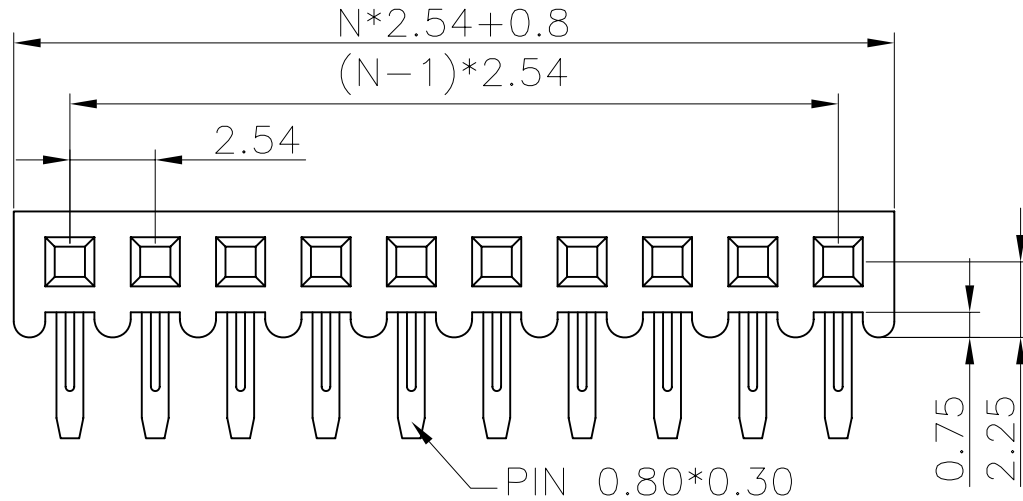

RECOMMEND PCB LAYOUT
(TOLERANCE=±0.05)

GENERAL TOLERANCE		ANGLE TOLERANCE		PROJECTION		TITLE	FEMALE HEADER PITCH	
X.	±0.60	X.	±5°	UNITS	mm	2.54mm R/A TYPE		
.X	±0.38	.X	±3°	SHEET SIZE	A4	SERIES	DS1024-02 SERIES	
.XX	±0.25	.XX	±2°	晨翔电子有限公司 CONNFLY CONNFLY ELECTRONIC CO. LTD				
DRAWING TYPE		CUSTOMER						
SCALE	1:1	SHEET	1 OF 1					
DRAWING NO.		C-DS1024-02-XXX						

REV.	DESCRIPTION	DRAWN	CHECKED	APPROVED
A	NEW RELEASE	YCH 11/09/08'		

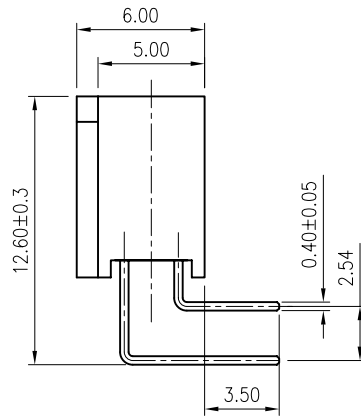
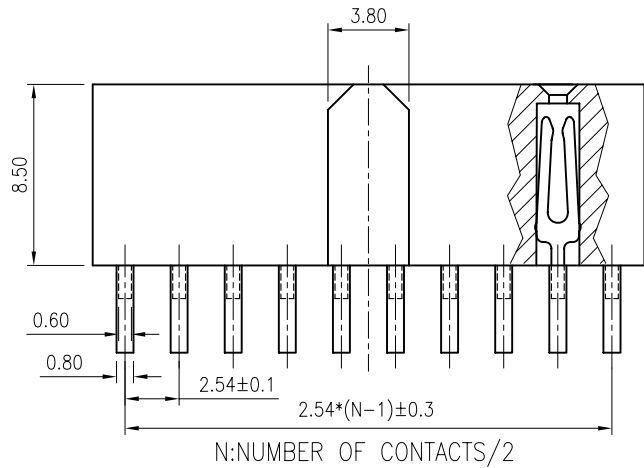
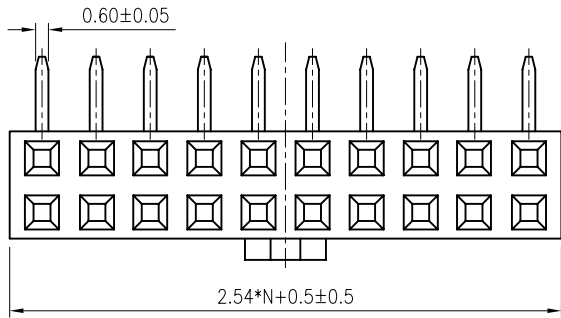

NOTES:

- ELECTRICAL CHARACTERISTICS:
 - CONTACT RESISTANCE: 30mΩ Max. INITIAL.
 - DIELECTRIC WITHSTANDING VOLTAGE: 500V AC(rms) FOR 1 MINUTE.
 - INSULATION RESISTANCE: 1000MΩ Min.
- ENVIRONMENT CHARACTERISTICS:
 - TEMPERATURE RANGE: -40°C~+105°C.
- PRODUCT NUMBER CODE:

DS1024-03- X X X

CONTACT PLATING
8: FULL GOLD FLASH
0: SECLECTIVE GOLD FLASH

MOUNTIING TYPE
R: R/A TYPE

No.OF CONTACTS
2*2-2*40

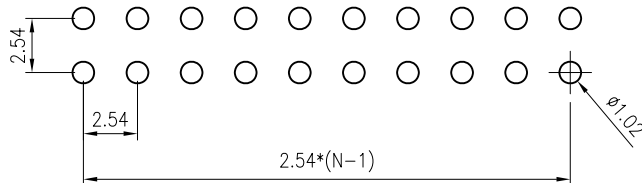

RECOMMEND PCB LAYOUT
TOLERANCE=±0.05

GENERAL TOLERANCE		ANGLE TOLERANCE		PROJECTION		TITLE	FEMALE HEADER PITCH 2.54mm	
X.	±0.60	X.	±5°	UNITS	mm			
.X	±0.38	.X	±3°	SHEET SIZE	A4	SERIES	DS1024-03 SERIES	
.XX	±0.25	.XX	±2°	晨翔电子有限公司 CONNFLY CONNFLY ELECTRONIC CO. LTD				
DRAWING TYPE		CUSTOMER						
SCALE	1:1	SHEET	1 OF 1					
DRAWING NO.		C-DS1024-03-XXX						

REV.	DESCRIPTION	DRAWN	CHECKED	APPROVED
A	NEW RELEASE	YCH 10/22/09'	~	

N=NUMBER OF CONTACTS/2

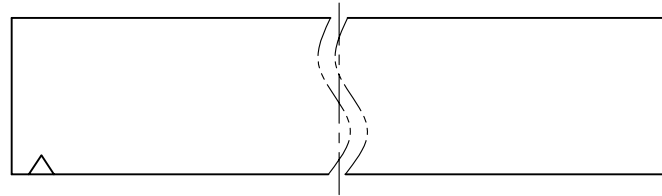

NOTES:

- ELECTRICAL CHARACTERISTICS:
 - CONTACT RESISTANCE: 20mΩ Max. INITIAL.
 - DIELECTRIC WITHSTANDING VOLTAGE: 500V AC(rms) FOR 1 MINUTE.
 - INSULATION RESISTANCE: 1000MΩ Min.
- ENVIRONMENT CHARACTERISTICS:
 - TEMPERATURE: -40°C~+105°C.
- PART NUMBER: DS1024-05
- PRODUCT NUMBER CODE:

DS1024-05 - X X X X

- X HOUSING COLOR
- B:BLACK
- X CONTACT PLATING
- 8: FULL GOLD FLASH
- X CONNECTOR TYPE
- S:SOCKET
- X No.OF CONTACTS
- 2*1-2*40

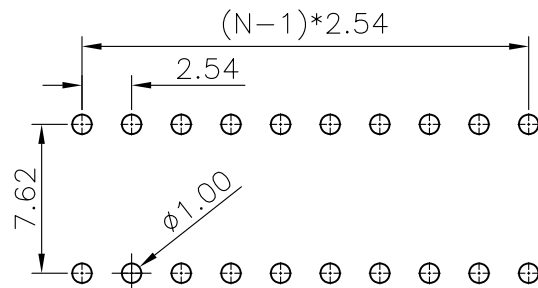
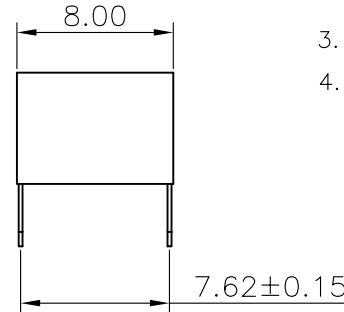
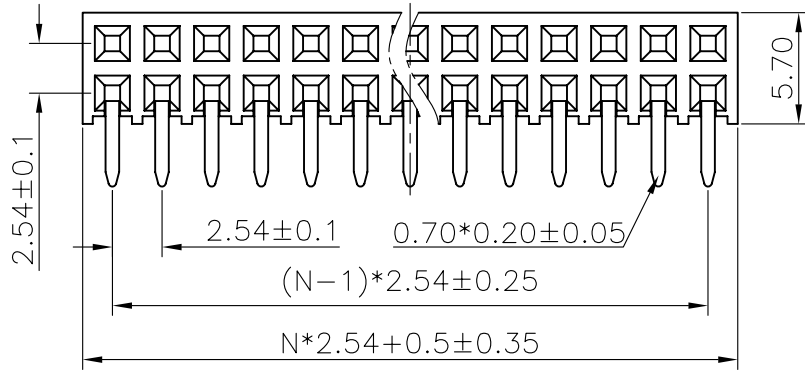

(TOLERANCE=±0.05)
RECOMMEND PCB LAYOUT

GENERAL TOLERANCE		ANGLE TOLERANCE		PROJECTION		TITLE	2.54mm FEMALE HEADER	
X.	±0.60	X.	±5'	UNITS	mm			
.X	±0.38	.X	±3'	SHEET SIZE	A4	SERIES	DS1024-05 SERIES	
.XX	±0.25	.XX	±2'	晨翔电子有限公司 CONNFLY CONNFLY ELECTRONIC CO. LTD				
DRAWING TYPE		CUSTOMER						
SCALE	1:1	SHEET	1 OF 1					
DRAWING NO.		C-DS1024-05-XXXX						

REV.	DESCRIPTION	DRAWN	CHECKED	APPROVED
A	NEW RELEASE	YCH 03/07/07'		

$N = \frac{1}{2}$ NUMBER OF CONTACTS

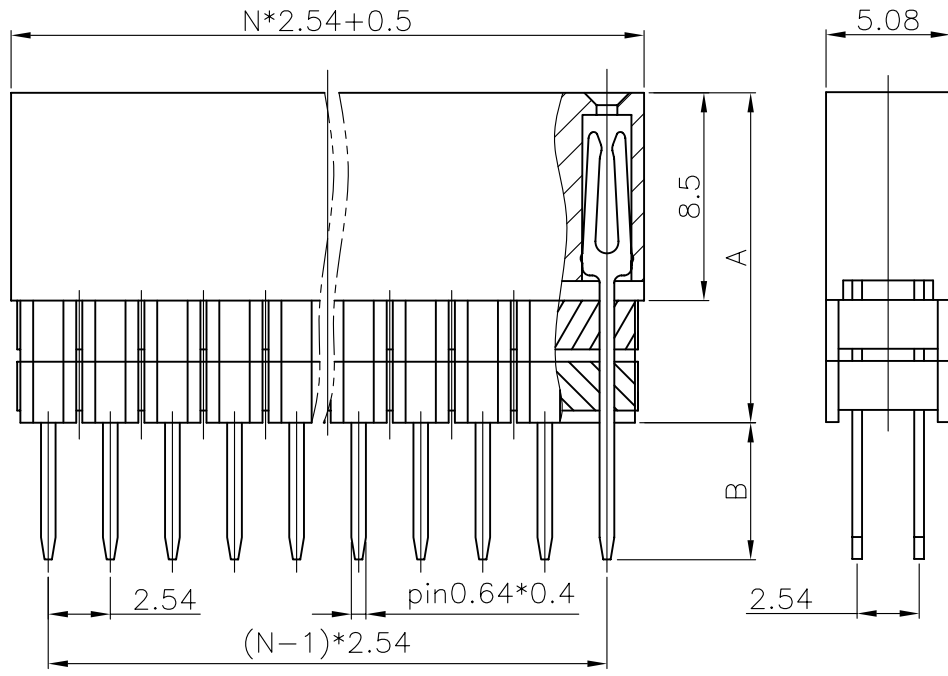

NOTES:

- ELECTRICAL CHARACTERISTICS:
 - CONTACT RESISTANCE: 50mΩ Max.
 - DIELECTRIC WITHSTANDING VOLTAGE: 500V AC(rms) FOR 1 MINUTE.
 - INSULATION RESISTANCE: 1000MΩ Min.
- ENVIRONMENT CHARACTERISTICS:
 - OPERATING TEMPERATURE: -40°C~+105°C.
 - RESISTANCE TO SOLDERING HEAT: 260±5°C, 5±0.5s.

TYPE	Dimension	
	A	B
1	13.50	6.50
2	11.05	2.50
3		
4		
5		
6		
7		
8		
9		
10		
11		
12		
13		
14		
15		
16		
17		
18		
19		
20		
21		

3. PRODUCT NUMBER CODE:

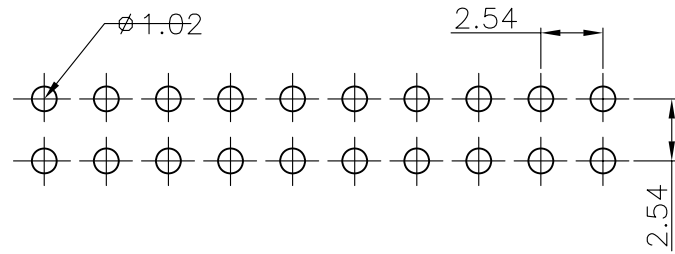
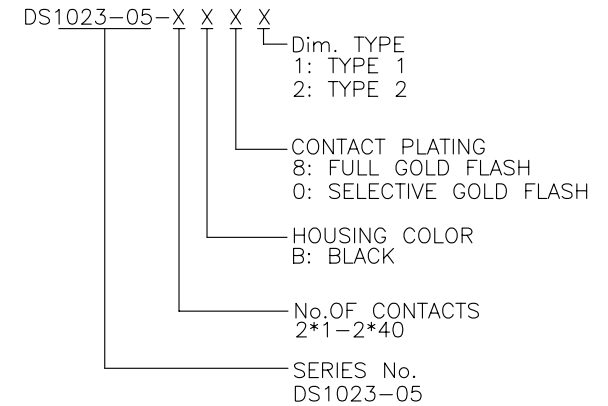

GENERAL TOLERANCE		ANGLE TOLERANCE		PROJECTION		TITLE	FEMALE HEADER PITCH
X.	±0.60	X.	±5°	UNITS	mm	2.54mm V/T STACK TYPE	
.X	±0.38	.X	±3°	SHEET SIZE	A4	SERIES	DS1023-05 SERIES
.XX	±0.25	.XX	±2°				
DRAWING TYPE		CUSTOMER					
SCALE	1:1	SHEET	1 OF 1				
DRAWING NO.		C-DS1023-05-XXXXX		CONNFLY CONNFLY ELECTRONIC CO. LTD			

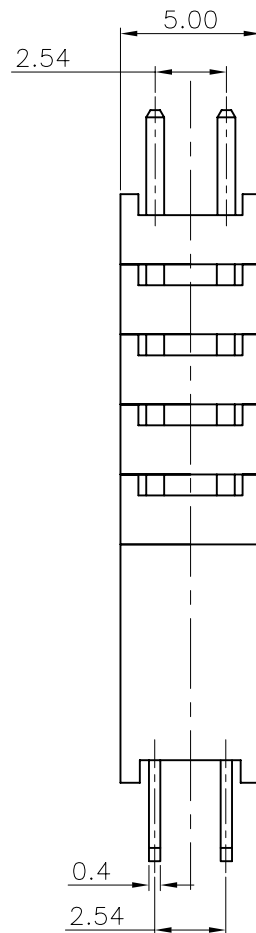
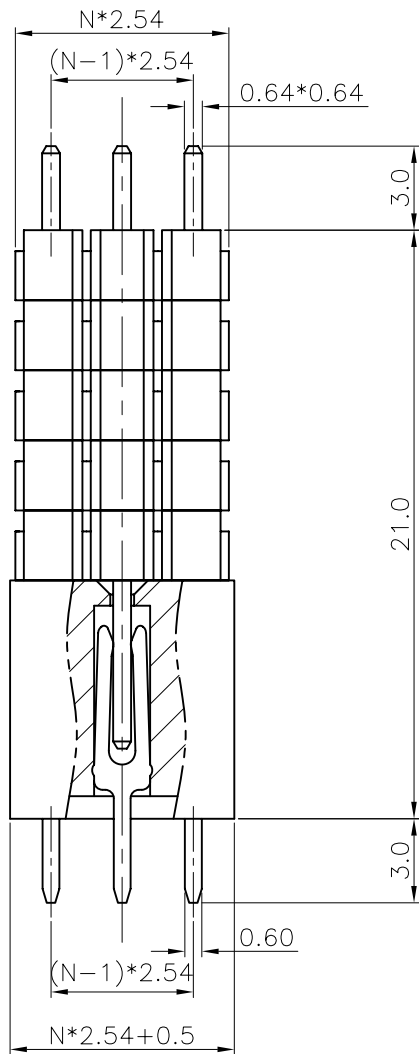
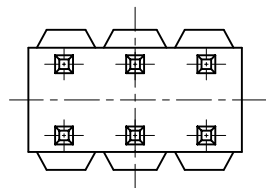

REV.	DESCRIPTION	DRAWN	CHECKED	APPROVED
A	NEW RELEASE	YCH 03/07/07'	~	

NOTES:

- ELECTRICAL CHARACTERISTICS:
 - CONTACT RESISTANCE: 50mΩ Max.
 - DIELECTRIC WITHSTANDING VOLTAGE: 500V AC(rms) FOR 1 MINUTE.
 - INSULATION RESISTANCE: 1000MΩ Min.
- ENVIRONMENT CHARACTERISTICS:
 - OPERATING TEMPERATURE: -10°C~+105°C.

3. PRODUCT NUMBER CODE:

DS1023-04 - X X X

CONTACT PLATING
0: SELETIVE GOLD FLASH
8: FULL GOLD FLASH

HOUSING COLOR
B: BLACK

No.OF CONTACTS
2*1-2*40

SERIES No.
DS1023-04

$N = \frac{1}{2}$ NUMBER OF CONTACTS

GENERAL TOLERANCE		ANGLE TOLERANCE	
X.	±0.60	X.	±5°
.X	±0.38	.X	±3°
.XX	±0.25	.XX	±2°

PROJECTION	TITLE
UNITS	Female Header with Pin Header pitch 2.54mm V/T Stack TYPE
SHEET SIZE	SERIES DS1023-04 SERIES

DRAWING TYPE	CUSTOMER
SCALE	1:1 SHEET 1 OF 1
DRAWING NO.	C-DS1023-04-XXXXXX

晨翔电子有限公司
CONNFLY CONNFLY ELECTRONIC CO. LTD

REV.	DESCRIPTION	DRAWN	CHECKED	APPROVED
A	NEW RELEASE	YCH 01/24/08'		

NOTES:

- MATERIAL
 - INSULATOR MATERIAL:HIGH TEMPERATURE (UL 94V-0).
 - CONTACT MATERIAL:COPPER ALLOY.
- SPECIFICATION
 - TEMPERATURE:-40° to +105°C.
 - DIELECTRIC WITHSTANDING VOLTAGE:AC 500V AC.
 - INSULATION RESISTANCE:1000MΩ min.
 - CONTACT RESISTANCE:20mΩ max.
 - CURRENT RATING:3A.
- PART NUMBER: DS1023-10
- PRODUCT NUMBER CODE:
DS1023-10 - X X X X X X X X
 - POST SUPPORT
 - S:W/ POST
 - X:W/O POST
 - PACKING TYPE
 - T:TRAY
 - R:TAPE ON REEL
 - B:TUBE
 - PICK UP SUPPORT
 - S: W/
 - X: W/O
 - BEND TYPE
 - 1: R1 TYPE
 - 2: R2 TYPE
 - CONTACT PLATING
 - 8: FULL GLOD FLASH
 - 0: SELECTIVE GLOD FLASH
 - HOUSING COLOR
 - B: BLACK
 - No.of Contacts
 - 1*1 - 1*40

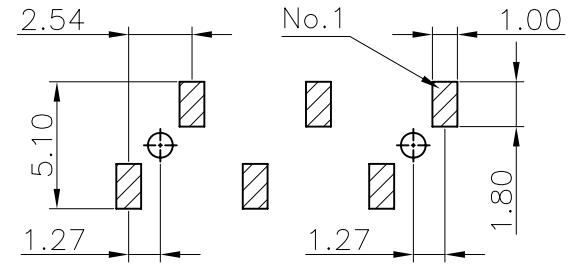
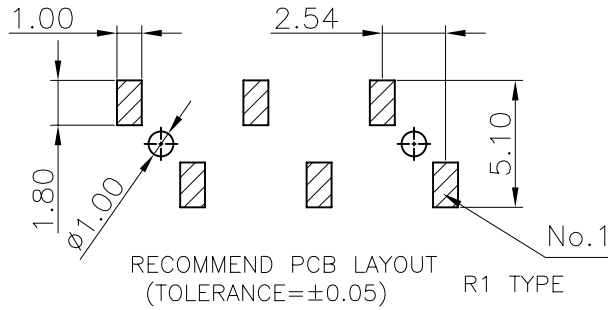
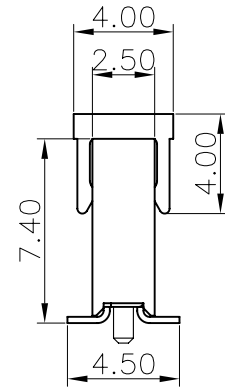
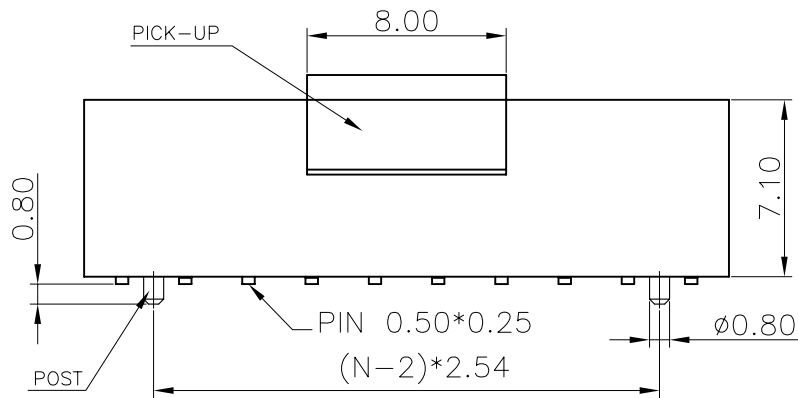
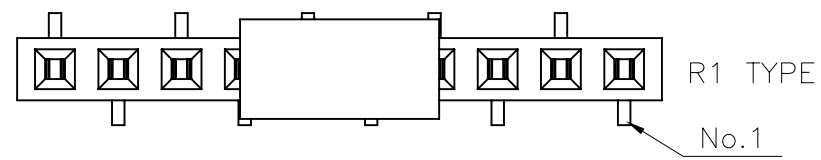
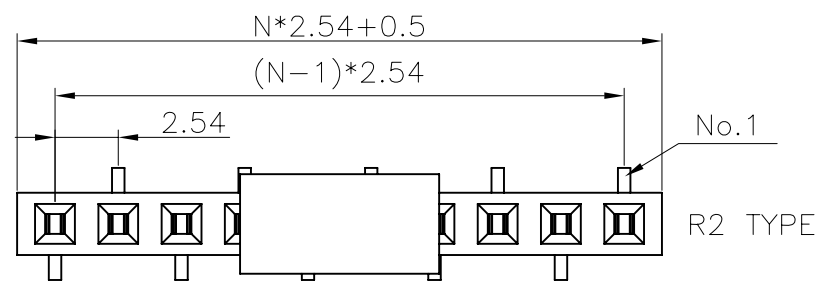

GENERAL TOLERANCE		ANGLE TOLERANCE		PROJECTION		TITLE	FEMALE HEADER PITCH	
X.	±0.60	X.	±5°	UNITS	mm		2.54mm SMT TYPE H=7.1mm	
.X	±0.38	.X	±3°	SHEET SIZE	A4	SERIES	DS1023-10 SERIES	
.XX	±0.25	.XX	±2°	晨翔电子有限公司 CONNFLY CONNFLY ELECTRONIC CO. LTD				
DRAWING TYPE		CUSTOMER						
SCALE	1:1	SHEET	1 OF 1					
DRAWING NO.		C-DS1023-10-XXXXX						

REV.	DESCRIPTION	DRAWN	CHECKED	APPROVED
A	NEW RELEASE	YCH 11/20/07'	~	

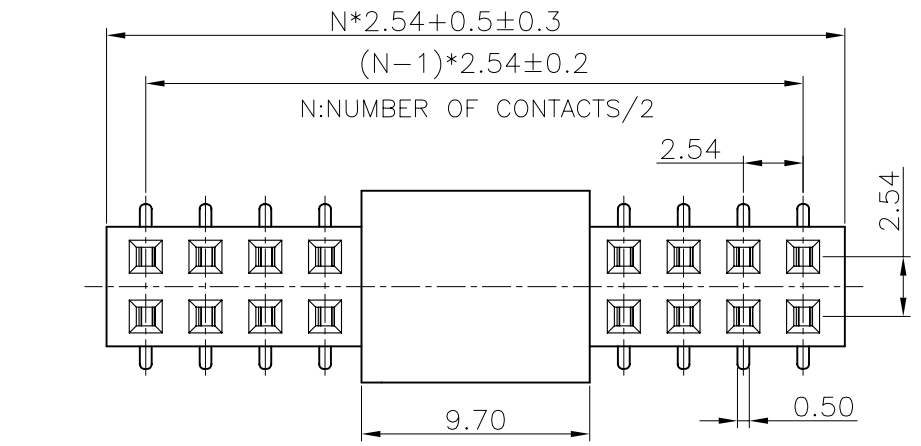

DIM.	A
TYPE 1	8.50
TYPE 2	5.00

- NOTES:
- MATERIAL
 - INSULATOR MATERIAL:THERMOPLASTIC(UL 94V-0).
 - CONTACT MATERIAL:COPPER ALLOY.
 - SPECIFICATION
 - TEMPERATURE:-40° to +105°C.
 - DIELECTRIC WITHSTANDING VOLTAGE:AC 500V AC.
 - INSULATION RESISTANCE:1000MΩ min.
 - CONTACT RESISTANCE:20mΩ max.
 - CURRENT RATING:3A.
 - PRODUCT NUMBER CODE:
 DS1023-15 - X X X X X X
 PROFILE HEIGHT(DIM A)
 1: 8.5mm
 2: 5.0mm
 POST SUPPORT
 S:W/ POST
 X:W/O POST
 PACKING TYPE
 T:TRAY
 R:TAPE ON REEL
 B:TUBE
 PICK UP SUPPORT
 S:W/ PICK UP
 X:W/O PICK UP
 CONTACT PLATING
 8: FULL GOLD FLASH
 0: Selective gold flash
 HOUSING COLOR
 B:BLACK
 No.OF CONTACTS
 2*2-2*40

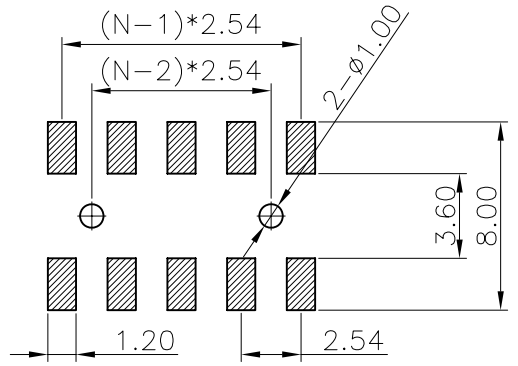
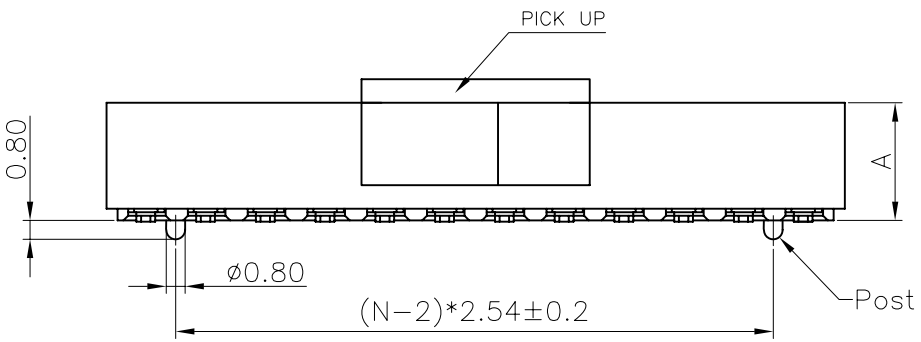
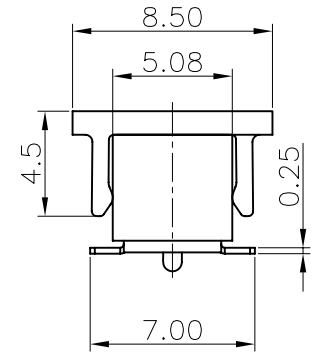

RECOMMEND PCB LAYOUT
(TOLERANCE=±0.05)

GENERAL TOLERANCE		ANGLE TOLERANCE	
X.	±0.60	X.	±5°
.X	±0.38	.X	±3°
.XX	±0.25	.XX	±2°

PROJECTION	TITLE	FEMALE HEADER PITCH	
	mm	2.54mm SMT TYPE H=8.5/5.0mm	
SHEET SIZE	A4	SERIES	DS1023-15 SERIES

DRAWING TYPE	CUSTOMER		
SCALE	1:1	SHEET	1 OF 1
DRAWING NO.	C-DS1023-15-XXXXXXX		

晨翔电子有限公司
CONNFLY CONNFLY ELECTRONIC CO. LTD

REV.	DESCRIPTION	DRAWN	CHECKED	APPROVED
A	NEW RELEASE	LGB 01/18/10'		

NOTES:

- MATERIAL
 - INSULATOR MATERIAL:THERMOPLASTIC(UL 94V-0).
 - CONTACT MATERIAL:COPPER ALLOY.
- SPECIFICATION
 - TEMPERATURE:-40° to +105°C.
 - DIELECTRIC WITHSTANDING VOLTAGE:AC 500V AC.
 - INSULATION RESISTANCE:1000MΩ min.
 - CURRENT RATING:3A.

3. PART NUMBER: DS1023-16

4. PRODUCT NUMBER CODE:

DS1023-16 - X X X X X X X X

- DIM. A TYPE
 - 1:8.5mm
 - 2:5.0mm
- POST SUPPORT
 - S:W/ POST
 - X:W/O POST
- PACKING TYPE
 - T:TRAY
 - R:TAPE ON REEL
 - B:TUBE
- PICK UP SUPPORT
 - S:W/ PICK UP
 - X:W/O PICK UP
- BEND TYPE
 - 1: R1 TYPE
 - 2: R2 TYPE
- CONTACT PLATING
 - 8: FULL GOLD FLASH
- HOUSING COLOR
 - B:BLACK
- No.OF CONTACTS
 - 1*2-1*40

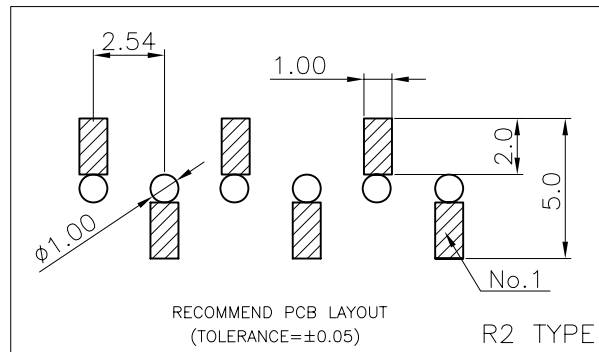
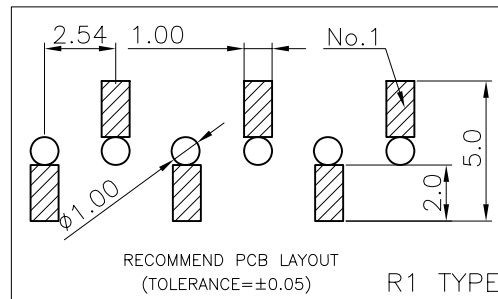
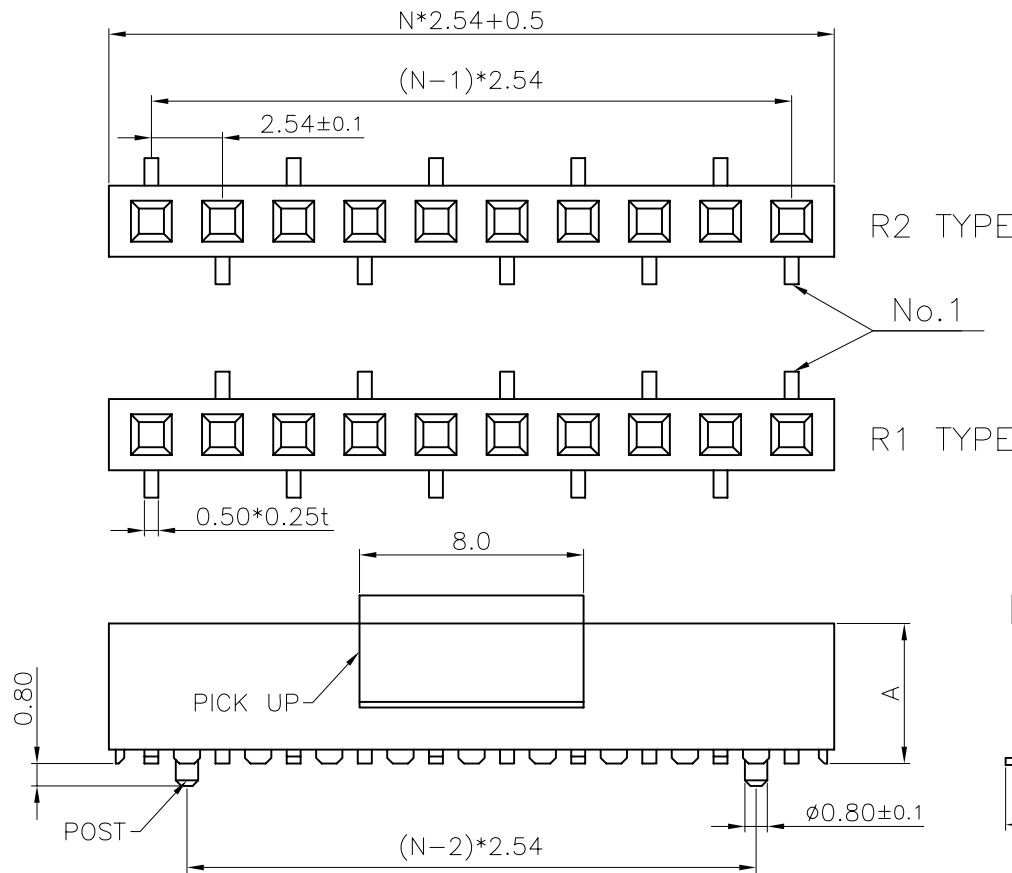

GENERAL TOLERANCE		ANGLE TOLERANCE	
X.	±0.60	X.	±5°
.X	±0.38	.X	±3°
.XX	±0.25	.XX	±2°

DRAWING TYPE	CUSTOMER		
SCALE	1:1	SHEET	1 OF 1
DRAWING NO.	C-DS1023-16-XXXXXXX		

PROJECTION	TITLE	FEMALE HEADER PITCH	
		2.54mm SMT TYPE H=8.5/5.0mm	
UNITS	mm	SERIES	DS1023-16 SERIES

晨翔电子有限公司
CONNFLY CONNFLY ELECTRONIC CO. LTD

REV.	DESCRIPTION	DRAWN	CHECKED	APPROVED
A	NEW RELEASE	YCH 01/24/08'		

NOTES:

- MATERIAL
 - INSULATOR MATERIAL:THERMOPLASTIC(UL 94V-0).
 - CONTACT MATERIAL:COPPER ALLOY.
- SPECIFICATION
 - TEMPERATURE: -40°C~+105°C.
 - DIELECTRIC WITHSTANDING VOLTAGE:AC 500V AC.
 - INSULATION RESISTANCE:1000MΩ min.
 - CONTACT RESISTANCE:20mΩ max.
 - CURRENT RATING:3A.
- PART NUMBER: DS1023-11
- PRODUCT NUMBER CODE:
DS1023-11 - X X X X X X
 - POST SUPPORT
 - S:W/ POST
 - X:W/O POST
 - PACKING TYPE
 - T:TRAY
 - R:TAPE ON REEL
 - B:TUBE
 - PICK UP SUPPORT
 - S: W/
 - X: W/O
 - CONTACT PLATING
 - 8: FULL GLOD FLASH
 - 0: SELECTIVE GLOD FLASH
 - HOUSING COLOR
 - B: BLACK
 - No.of Contacts
 - 2*2 - 2*40

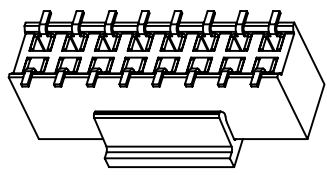
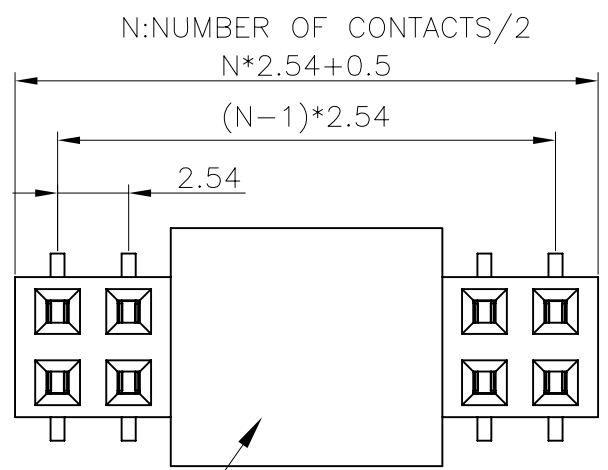

3D MODEL
Scale 1:2

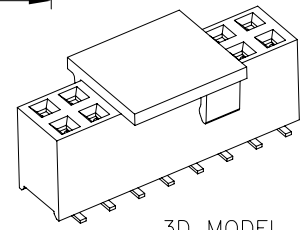
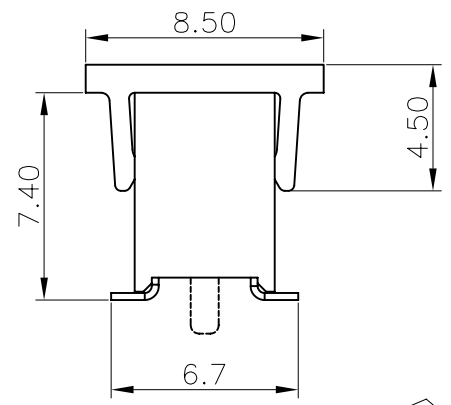
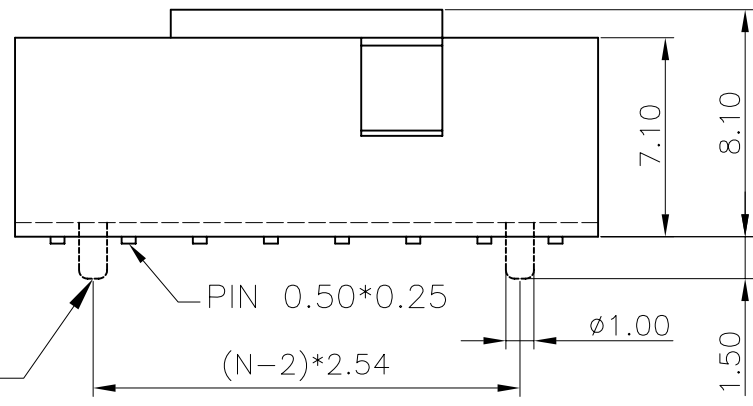

3D MODEL
Scale 1:2

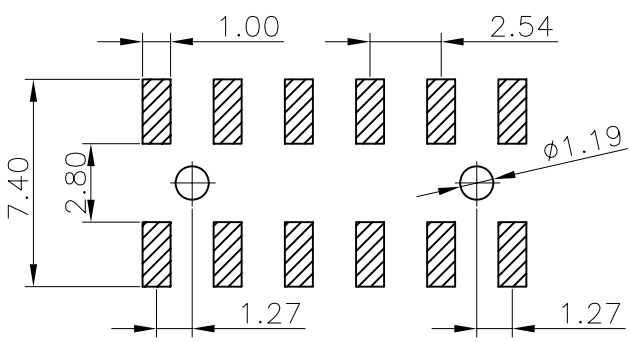

GENERAL TOLERANCE		ANGLE TOLERANCE		PROJECTION		TITLE	FEMALE HEADER PITCH	
X.	±0.60	X.	±5°	UNITS	mm		2.54mm SMT TYPE H=7.1mm	
.X	±0.38	.X	±3°	SHEET SIZE	A4	SERIES	DS1023-11 SERIES	
.XX	±0.25	.XX	±2°	晨翔电子有限公司 CONNFLY ELECTRONIC CO. LTD				
DRAWING TYPE		CUSTOMER						
SCALE	1:1	SHEET	1 OF 1					
DRAWING NO.		C-DS1023-11-XXXX						

REV.	DESCRIPTION	DRAWN	CHECKED	APPROVED
A	NEW RELEASE	YCH 02/23/08'		

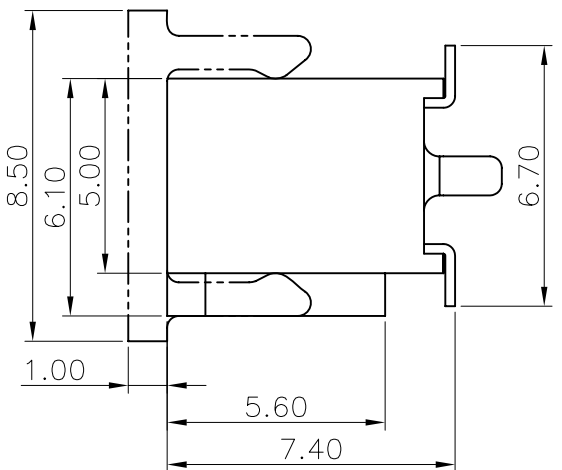
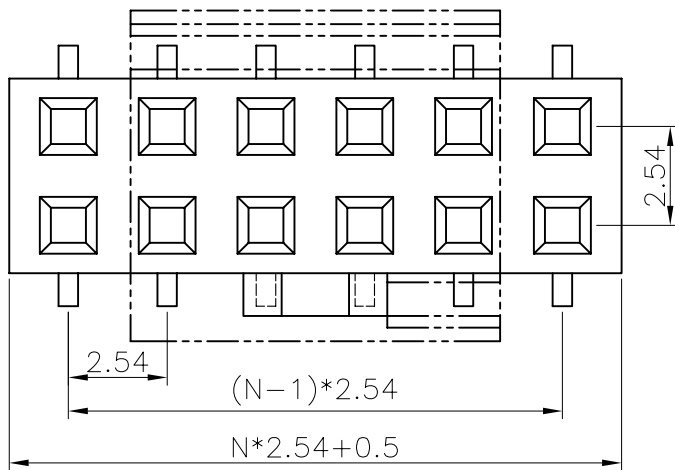

- NOTES:
- MATERIAL
 - INSULATOR MATERIAL:THERMOPLASTIC(UL 94V-0).
 - CONTACT MATERIAL:COPPER ALLOY.
 - SPECIFICATION
 - TEMPERATURE:-40° to +105°C.
 - DIELECTRIC WITHSTANDING VOLTAGE:AC 500V AC.
 - INSULATION RESISTANCE:1000MΩ min.
 - CURRENT RATING:3A.
 - PART NUMBER: DS1023-17
 - PRODUCT NUMBER CODE:
 DS1023-17 - X X X X X X
 POST SUPPORT
 S:W/ POST
 X:W/O POST
 PACKING TYPE
 T:TRAY
 R:TAPE ON REEL
 B:TUBE
 PICK UP SUPPORT
 S:W/ PICK UP
 X:W/O PICK UP
 CONTACT PLATING
 8: FULL GOLD FLASH
 0: Selective gold flash
 HOUSING COLOR
 B:BLACK
 No.OF CONTACTS
 2*2-2*40

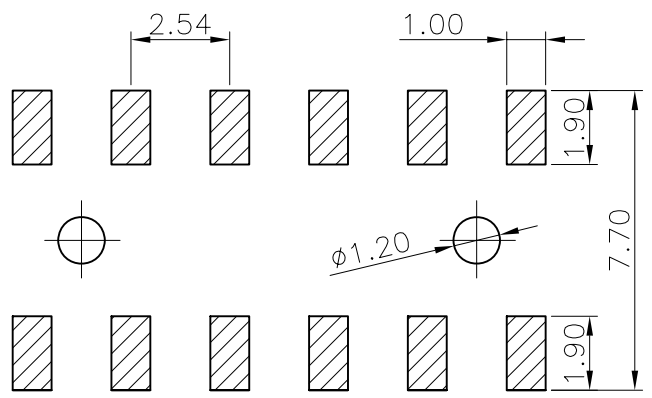
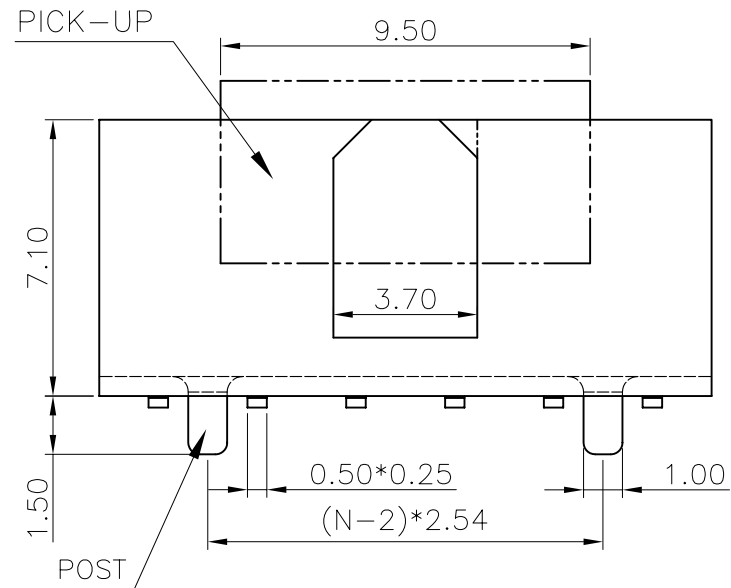

GENERAL TOLERANCE		ANGLE TOLERANCE		PROJECTION		TITLE	FEMALE HEADER PITCH 2.54mm
X.	±0.60	X.	±5°	UNITS	mm	SMT TYPE H=7.1mm W/ POLARIZATION	
.X	±0.38	.X	±3°	SHEET SIZE	A4	SERIES	DS1023-17 SERIES
.XX	±0.25	.XX	±2°	晨翔电子有限公司 CONNFLY CONNFLY ELECTRONIC CO. LTD			
DRAWING TYPE		CUSTOMER					
SCALE	1:1	SHEET	1 OF 1				
DRAWING NO.		C-DS1023-17-XXXXXX					

REV.	DESCRIPTION	DRAWN	CHECKED	APPROVED
A	NEW RELEASE	YCH 10/22/09'		

N=NUMBER OF CONTACTS/2

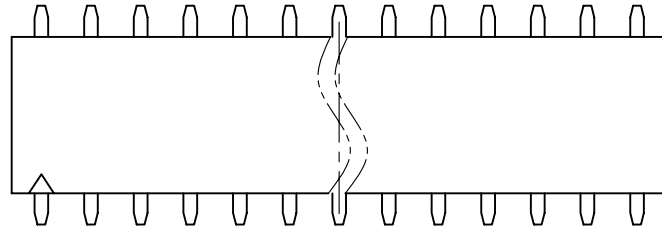

NOTES:

- ELECTRICAL CHARACTERISTICS:
 - CONTACT RESISTANCE: 20mΩ Max. INITIAL.
 - DIELECTRIC WITHSTANDING VOLTAGE: 500V AC(rms) FOR 1 MINUTE.
 - INSULATION RESISTANCE: 1000MΩ Min.
- ENVIRONMENT CHARACTERISTICS:
 - TEMPERATURE: -40°C~+105°C.
- PART NUMBER: DS1024-06
- PRODUCT NUMBER CODE:

DS1024-06 - X X X X

HOUSING COLOR
B:BLACK
CONTACT PLATING
8: FULL GOLD FLASH
CONNECTOR TYPE
S:SOCKET
No.OF CONTACTS
2*1-2*40

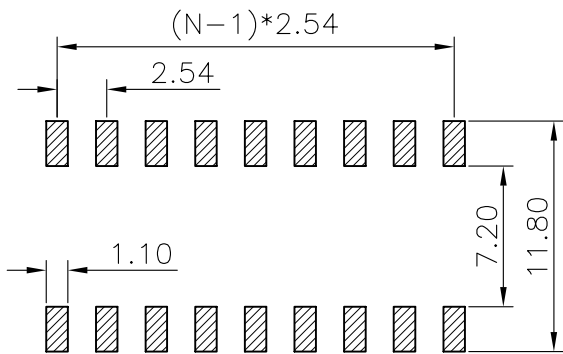
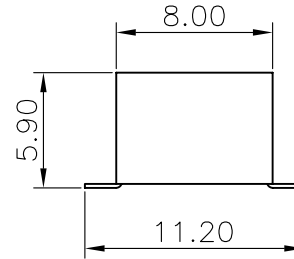
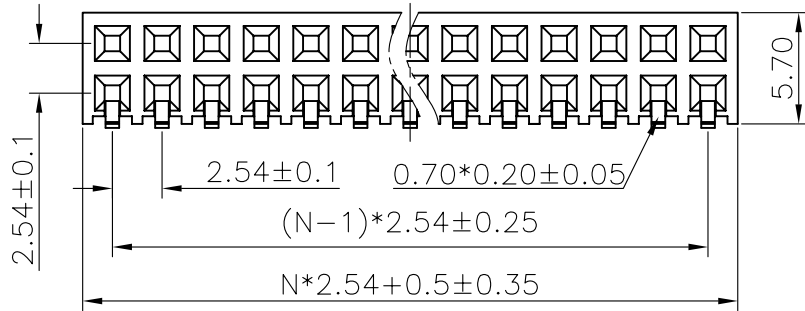

(TOLERANCE=±0.05)
RECOMMEND PCB LAYOUT

GENERAL TOLERANCE		ANGLE TOLERANCE		PROJECTION		TITLE	FEMALE HEADER PITCH 2.54mm	
X.	±0.60	X.	±5'	UNITS	mm	SMT TYPE		
.X	±0.38	.X	±3'	SHEET SIZE	A4	SERIES	DS1024-06 SERIES	
.XX	±0.25	.XX	±2'	晨翔电子有限公司 CONNFLY CONNFLY ELECTRONIC CO. LTD				
DRAWING TYPE		CUSTOMER						
SCALE	1:1	SHEET	1 OF 1					
DRAWING NO.		C-DS1024-06-XXXX						