

REV.	DESCRIPTION	DRAWN	CHECKED	APPROVED
A	NEW RELEASE	LJH 09/22/05'		

N:NUMBER OF CONTACTS

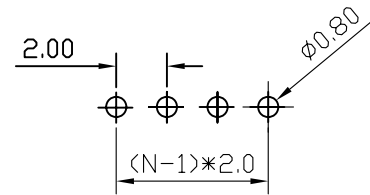
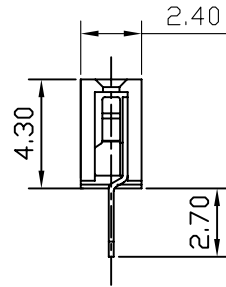
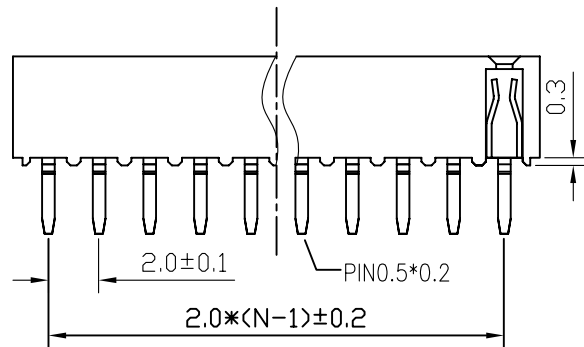
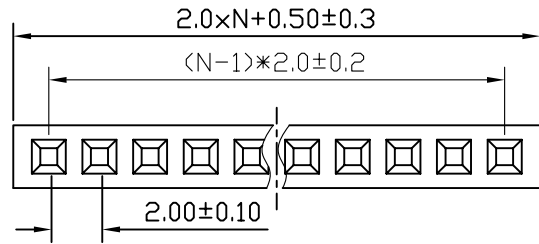

RECOMMEND PCB LAYOUT
(TOLERANCE=±0.05)

NOTES:

- ELECTRICAL CHARACTERISTICS:
 - CONTACT RESISTANCE: 20mΩ Max. INITIAL.
 - DIELECTRIC WITHSTANDING VOLTAGE: 500V AC(rms) FOR 1 MINUTE.
 - INSULATION RESISTANCE: 1000MΩ Min.
- ENVIRONMENT CHARACTERISTICS:
 - TEMPERATURE: -40°C~+105°C.
- PART NUMBER: DS1026-01
- PRODUCT NUMBER CODE:

DS1026-01 - X X X X X

- X CONTACTS TYPE
- V:VERTICAL TYPE
- HOUSING COLOR
- B:BLACK
- CONTACT PLATING
- 8: FULL GOLD FLASH
- CONNECTOR TYPE
- S:SOCKET
- No.OF CONTACTS
- 1*1-1*X
- SERIES No.
- DS1026-01

GENERAL TOLERANCE		ANGLE TOLERANCE		PROJECTION		TITLE	FEMALE HEADER PITCH 2.0mm TYPE	
X.	±0.60	X.	±5'	UNITS	mm			
.X	±0.38	.X	±3'	SHEET SIZE	A4	SERIES	DS1026-01 SERIES	
.XX	±0.25	.XX	±2'	晨翔电子有限公司 CONNFLY CONNFLY ELECTRONIC CO. LTD				
DRAWING TYPE		CUSTOMER						
SCALE	1:1	SHEET	1 OF 1					
DRAWING NO.		C-DS1026-01-XXXXX						

REV.	DESCRIPTION	DRAWN	CHECKED	APPROVED
A	NEW RELEASE	LJH 09/22/05'		LJC 05/09/06

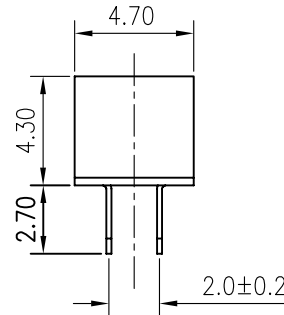
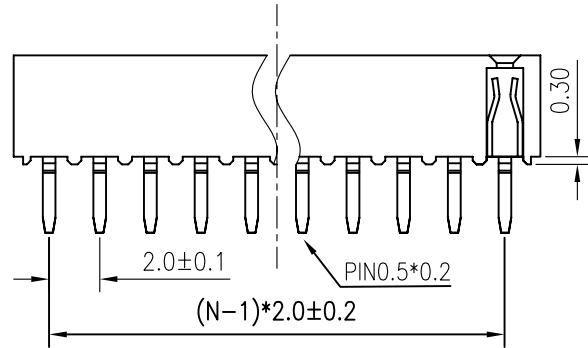
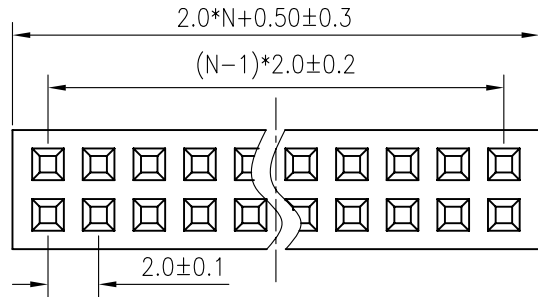

N: NUMBER OF CONTACTS/2

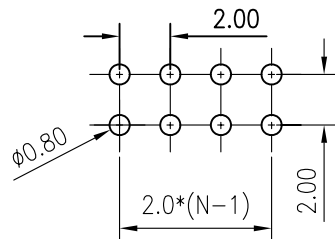

RECOMMEND PCB LAYOUT(TOLERANCE=±0.05)

NOTES:

- ELECTRICAL CHARACTERISTICS:
 - CONTACT RESISTANCE: 20mΩ Max. INITIAL.
 - DIELECTRIC WITHSTANDING VOLTAGE: 500V AC(rms) FOR 1 MINUTE.
 - INSULATION RESISTANCE: 1000MΩ Min.
- ENVIRONMENT CHARACTERISTICS:
 - OPERATING TEMPERATURE: 0°C~+85°C.
 - STORAGE TEMPERATURE: -20°C~+70°C.

3. PART NUMBER: DS1026-05

4. PRODUCT NUMBER CODE:

DS1026-05 - X X X X X

- CONTACTS TYPE
V:VERTICAL TYPE
- HOUSING COLOR
B:BLACK
- CONTACT PLATING
8: FULL GOLD FLASH
- CONNECTOR TYPE
S:SOCKET
- No.OF CONTACTS
2*2-2*X
- SERIES No.
DS1026-05

GENERAL TOLERANCE	ANGLE TOLERANCE	PROJECTION		TITLE	FEMALE HEADER PITCH 2.0mm TYPE	
X. ±0.60	X. ±5'	UNITS	mm			
.X ±0.38	.X ±3'	SHEET SIZE	A4	SERIES	DS1026-05 SERIES	
.XX ±0.25	.XX ±2'					

2	CONTACT		COPPER ALLOY	GOLD FLASH	DRAWING TYPE	CUSTOMER	
1	HOUSING		THERMOPLASTIC	UL 94 V-0	SCALE	1:1	SHEET 1 OF 1
ITEM	PART NAME	PART NO.	MATERILAS	FINISHED	DRAWING NO.	C-DS1026-05-XXXXX	

晨翔电子有限公司
CONNFLY CONNFLY ELECTRONIC CO. LTD

REV.	DESCRIPTION	DRAWN	CHECKED	APPROVED
A	NEW RELEASE	YCH 10/15/07'		

NOTES:

- ELECTRICAL CHARACTERISTICS:
 - CONTACT RESISTANCE: 20mΩ Max. INITIAL.
 - DIELECTRIC WITHSTANDING VOLTAGE: 500V AC(rms) FOR 1 MINUTE.
 - INSULATION RESISTANCE: 1000MΩ Min.
- ENVIRONMENT CHARACTERISTICS:
 - TEMPERATURE: -40°C~+105°C.
- PRODUCT NUMBER CODE:
 DS1026-06 - X X X X X
 CONTACTS TYPE V:VERTICAL
 HOUSING COLOR B:BLACK
 CONTACT PLATING 8: FULL GOLD FLASH
 CONNECTOR TYPE S:SOCKET
 No.OF CONTACTS 2*2-2*40
 SERIES No. DS1026-06

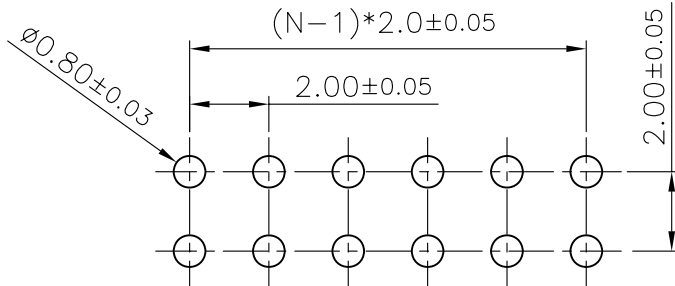
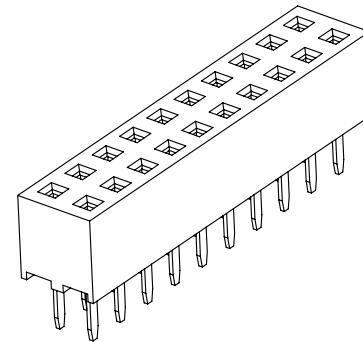
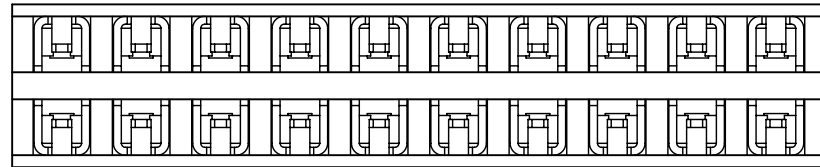
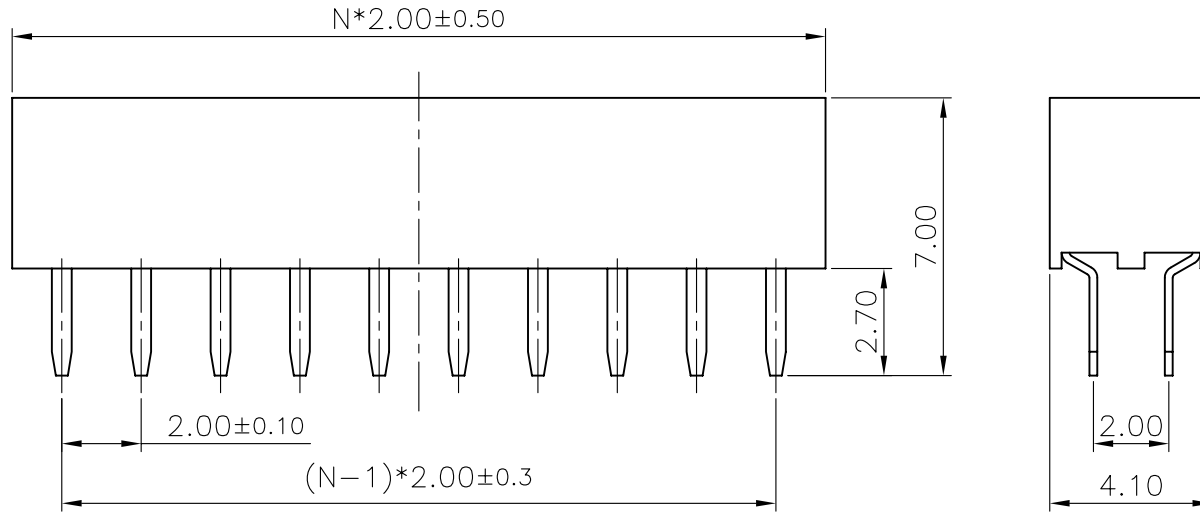

Recommend PCB layout

GENERAL TOLERANCE		ANGLE TOLERANCE	
X.	±0.60	X.	±5'
.X	±0.38	.X	±3'
.XX	±0.25	.XX	±2'

DRAWING TYPE	CUSTOMER		
SCALE	1:1	SHEET	1 OF 1
DRAWING NO.	C-DS1026-06-XXXXX-A		

PROJECTION	TITLE
	FEMALE HEADER PITCH 2.00mmTYPE
UNITS	mm
SHEET SIZE	A4
SERIES	DS1026-06 SERIES

晨翔电子有限公司
CONNFLY CONNFLY ELECTRONIC CO. LTD

REV.	DESCRIPTION	DRAWN	CHECKED	APPROVED
A	NEW RELEASE	LJH 09/22/05'		LJC 05/09/06

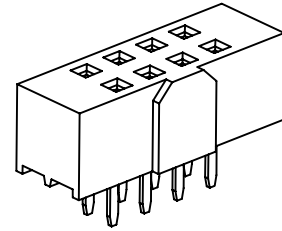
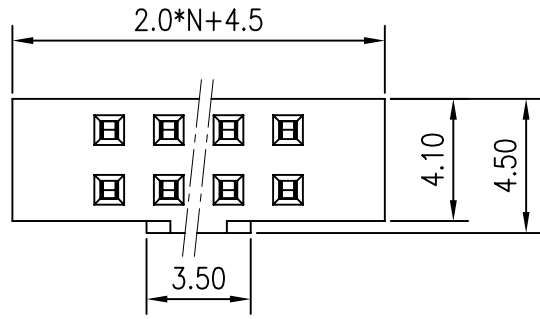

NOTES:

- ELECTRICAL CHARACTERISTICS:
 - CONTACT RESISTANCE: 20mΩ Max. INITIAL.
 - DIELECTRIC WITHSTANDING VOLTAGE: 500V AC(rms) FOR 1 MINUTE.
 - INSULATION RESISTANCE: 1000MΩ Min.
- ENVIRONMENT CHARACTERISTICS:
 - TEMPERATURE: -40°C~+105°C.
- PART NUMBER: DS1026-17
- PRODUCT NUMBER CODE: DS1026-17 - X X X X X

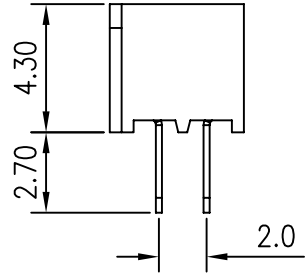
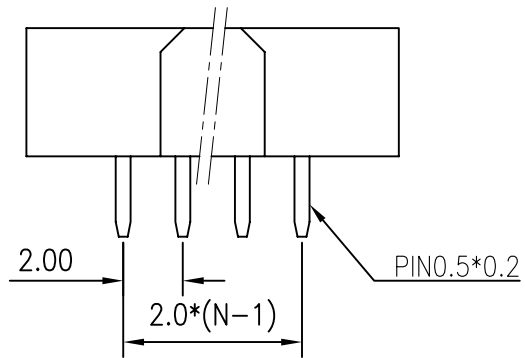

- CONTACTS TYPE
V:VERTICAL TYPE
- HOUSING COLOR
B:BLACK
- CONTACT PLATING
8: FULL GOLD FLASH
- CONNECTOR TYPE
S:SOCKET
- No.OF CONTACTS
2*4-2*32
- SERIES No.
DS1026-17

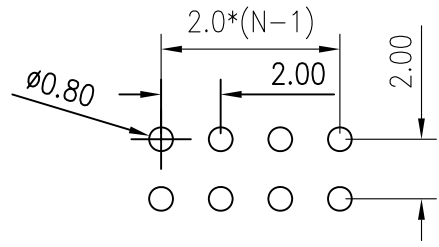

RECOMMEND PCB LAYOUT
(TOLERANCE=±0.05)

GENERAL TOLERANCE		ANGLE TOLERANCE		PROJECTION		TITLE	FEMALE HEADER PITCH 2.0mm W/ Polarization TYPE					
X.	±0.60	X.	±5'	UNITS	mm							
.X	±0.38	.X	±3'	SHEET SIZE	A4	SERIES	DS1026-17 SERIES					
.XX	±0.25	.XX	±2'									
DRAWING TYPE		CUSTOMER				晨翔电子有限公司 CONNFLY CONNFLY ELECTRONIC CO. LTD						
SCALE		1:1							SHEET		1 OF 1	
DRAWING NO.		C-DS1026-17-XXXXX										

REV.	DESCRIPTION	DRAWN	CHECKED	APPROVED
A	NEW RELEASE	LJH 05/08/05'		

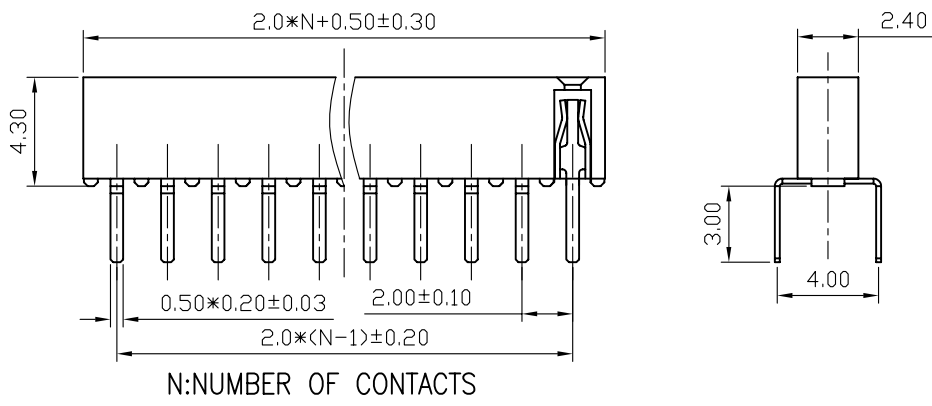
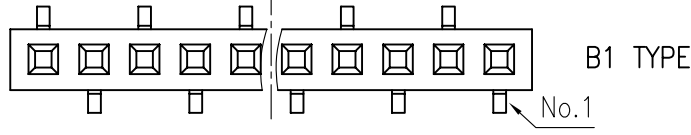
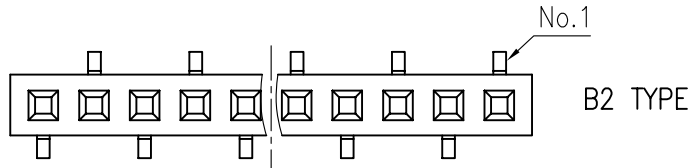

N:NUMBER OF CONTACTS

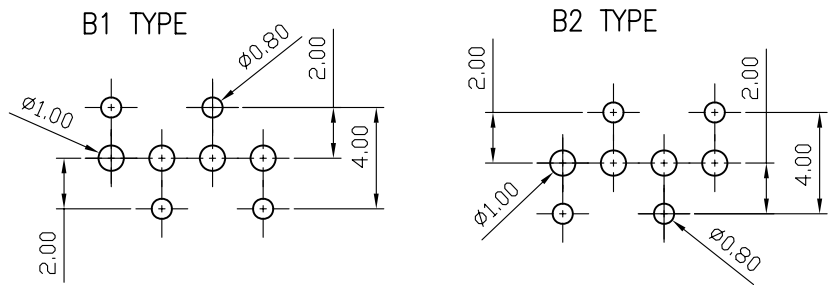

RECOMMEND PCB LAYOUT(TOLERANCE=±0.05)

NOTES:

- ELECTRICAL CHARACTERISTICS:
 - CONTACT RESISTANCE: 20mΩ Max. INITIAL.
 - DIELECTRIC WITHSTANDING VOLTAGE: 500V AC(rms) FOR 1 MINUTE.
 - INSULATION RESISTANCE: 1000MΩ Min.

2. ENVIRONMENT CHARACTERISTICS:

- TEMPERATURE: -40°C~+105°C.

3. PART NUMBER: DS1026-04

4. PRODUCT NUMBER CODE:

DS1026-04 - X X X X X X

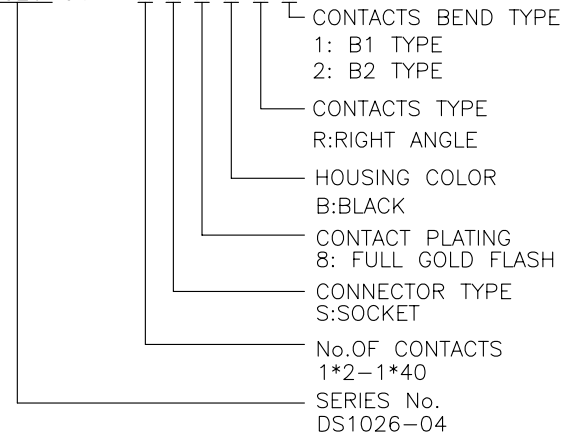

GENERAL TOLERANCE		ANGLE TOLERANCE	
X.	±0.60	X.	±5'
.X	±0.38	.X	±3'
.XX	±0.25	.XX	±2'

PROJECTION	TITLE	SINGLE ROW BOTTOM ENTRY TYPE	
UNITS	mm		
SHEET SIZE	A4	SERIES	DS1026-04 SERIES

DRAWING TYPE	CUSTOMER		
SCALE	1:1	SHEET	1 OF 1
DRAWING NO.	C-DS1026-04-XXXXXX		

晨翔电子有限公司
CONNFLY CONNFLY ELECTRONIC CO. LTD

REV.	DESCRIPTION	DRAWN	CHECKED	APPROVED
A	NEW RELEASE	LJH 06/22/05'		

NOTES:

- ELECTRICAL CHARACTERISTICS:
 - CONTACT RESISTANCE: 20mΩ Max. INITIAL.
 - DIELECTRIC WITHSTANDING VOLTAGE: 500V AC(rms) FOR 1 MINUTE.
 - INSULATION RESISTANCE: 1000MΩ Min.
- ENVIRONMENT CHARACTERISTICS:
 - OPERATING TEMPERATURE: 0°C~+85°C.
 - STORAGE TEMPERATURE: -20°C~+70°C.
- PART NUMBER: DS1026-11
- PRODUCT NUMBER CODE:
 DS1026-11 - X X X X X
 - CONTACTS TYPE
R:RIGHT ANGLE
 - HOUSING COLOR
B:BLACK
 - CONTACT PLATING
8: FULL GOLD FLASH
 - CONNECTOR TYPE
S:SOCKET
 - No.OF CONTACTS
2*1-2*X
 - SERIES No.
DS1026-11

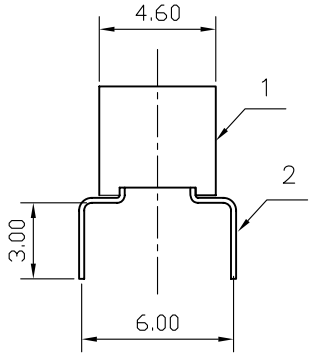
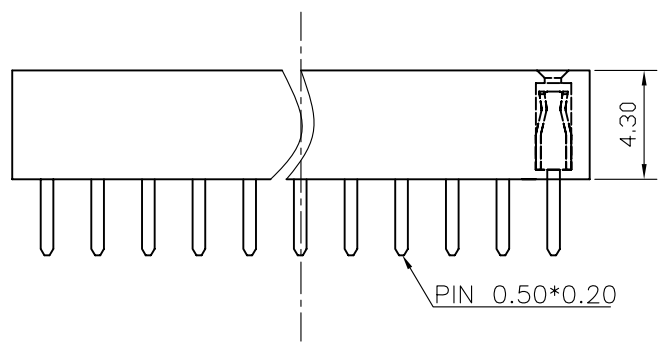
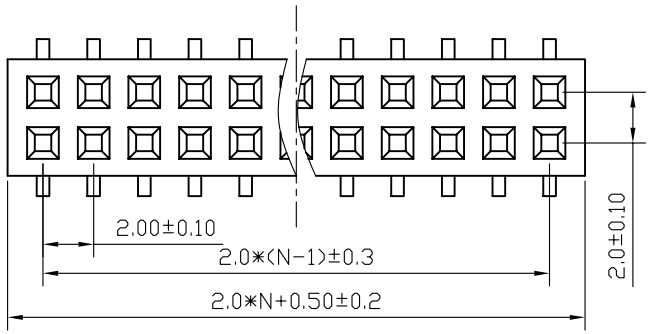

N: HALF OF PIN POSITIONS

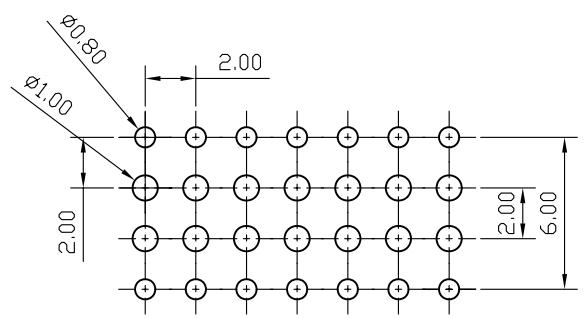

RECOMMEND PCB LAYOUT
(TOLERANCE=±0.05)

GENERAL TOLERANCE		ANGLE TOLERANCE	
X.	±0.60	X.	±5'
.X	±0.38	.X	±3'
.XX	±0.25	.XX	±2'

PROJECTION		TITLE	BOTTOM ENTRY TYPE DUAL ROW
UNITS	mm	SHEET SIZE	A4
SHEET SIZE	A4	SERIES	DS1026-11 SERIES

2	CONTACT		COPPER ALLOY	GOLD PLATED	DRAWING TYPE	CUSTOMER		
1	HOUSING		THERMOPLASTIC	UL 94 V-0	SCALE	1:1	SHEET	1 OF 1
ITEM	PART NAME	PART NO.	MATERILAS	FINISHED	DRAWING NO.	C-DS1026-11-XXXXX		

晨翔电子有限公司
CONNFLY CONNFLY ELECTRONIC CO. LTD

REV.	DESCRIPTION	DRAWN	CHECKED	APPROVED
A	NEW RELEASE	LJH 06/22/05'		

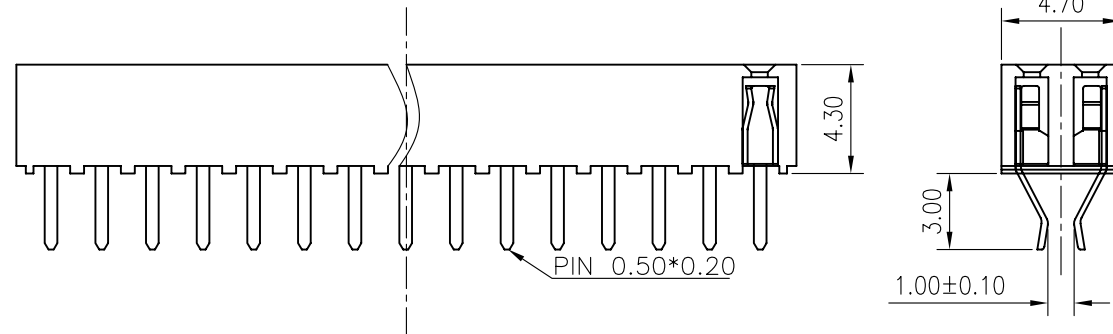
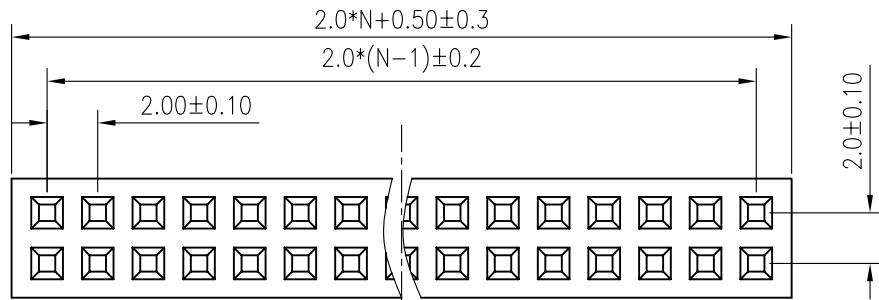

N: NUMBER OF CONTACTS/2

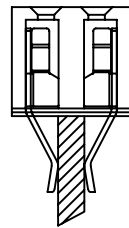

1.20mm PCB

NOTES:

- ELECTRICAL CHARACTERISTICS:
 - CONTACT RESISTANCE: 20mΩ Max. INITIAL.
 - DIELECTRIC WITHSTANDING VOLTAGE: 500V AC(rms) FOR 1 MINUTE.
 - INSULATION RESISTANCE: 1000MΩ Min.
- ENVIRONMENT CHARACTERISTICS:
 - OPERATING TEMPERATURE: -40°C~+105°C.
- PART NUMBER: DS1026-10
- PRODUCT NUMBER CODE:
DS1026-10 - X X X X X
 - CONTACTS TYPE
V:VERTICAL
 - HOUSING COLOR
B:BLACK
 - CONTACT PLATING
8: FULL GOLD FLASH
 - CONNECTOR TYPE
S:SOCKET
 - No.OF CONTACTS
2*1-2*X
 - SERIES No.
DS1026-10

GENERAL TOLERANCE		ANGLE TOLERANCE		PROJECTION		TITLE	STRADDLE TYPE DUAL ROW	
X.	±0.60	X.	±5'	UNITS	mm			
.X	±0.38	.X	±3'	SHEET SIZE	A4	SERIES	DS1026-10 SERIES	
.XX	±0.25	.XX	±2'	晨翔电子有限公司 CONNPLY CONNPLY ELECTRONIC CO. LTD				
DRAWING TYPE		CUSTOMER						
SCALE	1:1	SHEET	1 OF 1					
DRAWING NO.		C-DS1026-10-XXXXX						

REV.	DESCRIPTION	DRAWN	CHECKED	APPROVED
A	NEW RELEASE	YCH 06/04/07'		

NOTES:

- ELECTRICAL CHARACTERISTICS:
 - CONTACT RESISTANCE: 20mΩ Max. INITIAL.
 - DIELECTRIC WITHSTANDING VOLTAGE: 500V AC(rms) FOR 1 MINUTE.
 - INSULATION RESISTANCE: 1000MΩ Min.
- ENVIRONMENT CHARACTERISTICS:
 - TEMPERATURE: -40°C~+105°C.

3. PRODUCT NUMBER CODE:

DS1026-02 - X X X X X

- CONTACTS TYPE
R:RIGHT ANGLE
- HOUSING COLOR
B:BLACK
- CONTACT PLATING
8: FULL GOLD FLASH
- CONNECTOR TYPE
S:SOCKET
- No.OF CONTACTS
1*1-1*40
- SERIES No.
DS1026-02

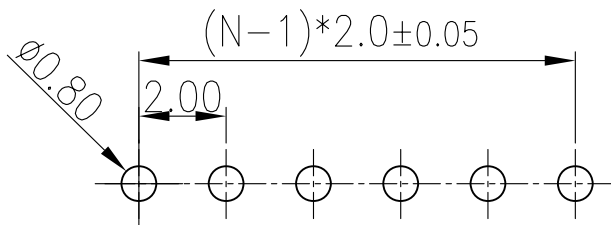
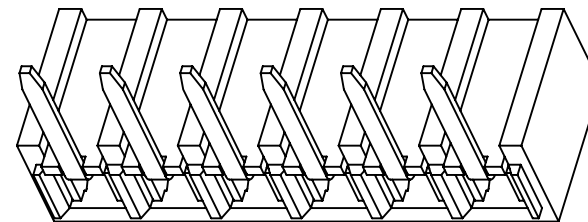
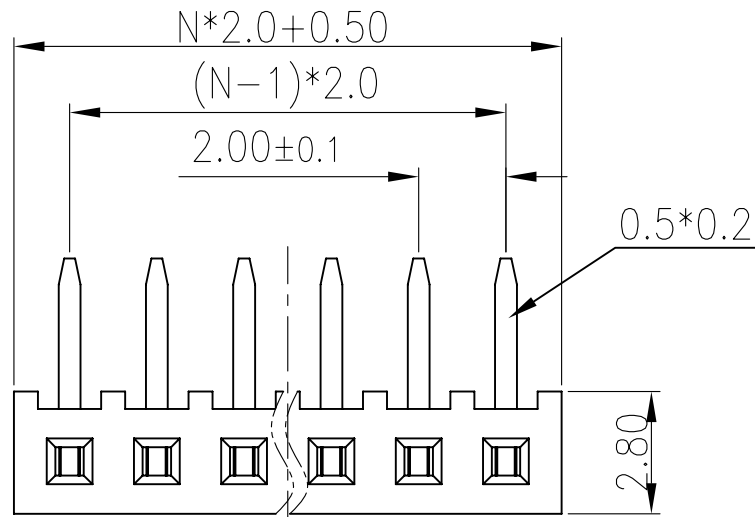
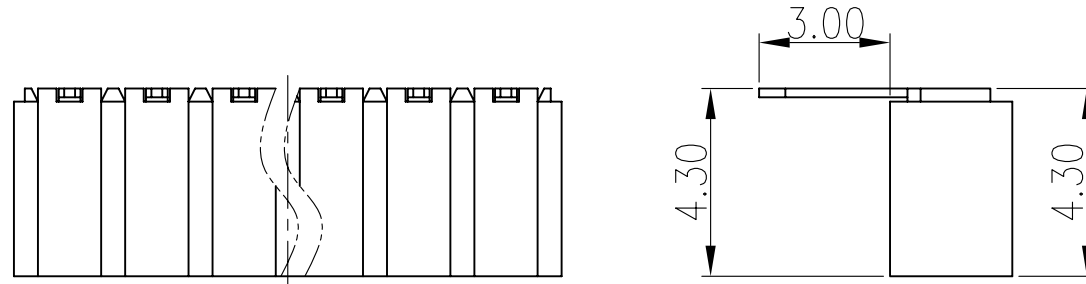

Recommend PCB layout

GENERAL TOLERANCE		ANGLE TOLERANCE	
X.	±0.60	X.	±5°
.X	±0.38	.X	±3°
.XX	±0.25	.XX	±2°

PROJECTION	TITLE
	FEMALE HEADER PITCH 2.00mmTYPE
UNITS	mm
SHEET SIZE	A4
SERIES	DS1026-02 SERIES

DRAWING TYPE	CUSTOMER		
SCALE	1:1	SHEET	1 OF 1
DRAWING NO.	C-DS1026-02-XXXXX-A		

晨翔电子有限公司
CONNFly CONNFly ELECTRONIC CO. LTD

REV.	DESCRIPTION	DRAWN	CHECKED	APPROVED
A	NEW RELEASE	LJH 06/22/05'		

N: NUMBER OF CONTACTS/2
 B: CUSTOMER LENGTH AVAILABLE

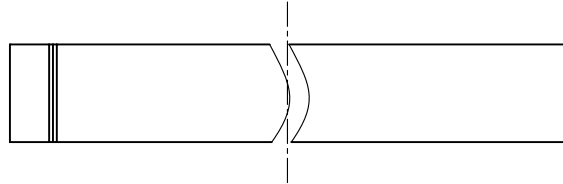

NOTES:

- ELECTRICAL CHARACTERISTICS:
 - CONTACT RESISTANCE: 20mΩ Max. INITIAL.
 - DIELECTRIC WITHSTANDING VOLTAGE: 500V AC(rms) FOR 1 MINUTE.
 - INSULATION RESISTANCE: 1000MΩ Min.
- ENVIRONMENT CHARACTERISTICS:
 - TEMPERATURE: -40°C~+105°C.
- PART NUMBER: DS1026-12
- PRODUCT NUMBER CODE:

DS1026-12 - X X X X X

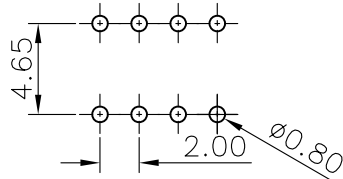
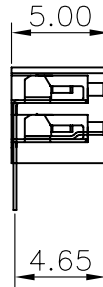
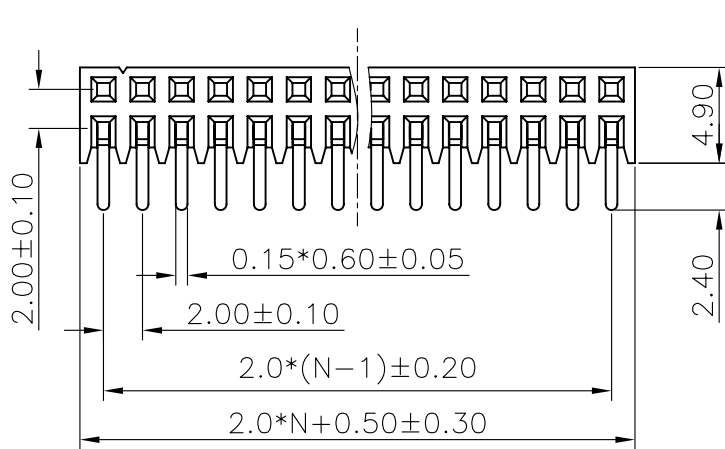
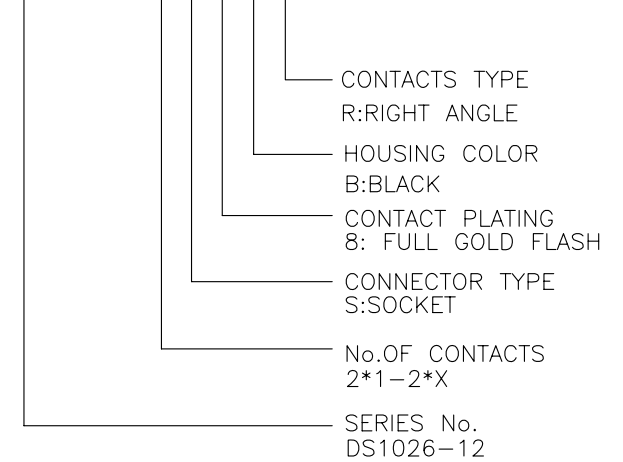

RECOMMEND PCB LAYOUT
 (TOLERANCE=±0.05)

GENERAL TOLERANCE		ANGLE TOLERANCE		PROJECTION		TITLE	SIDE ENTRY RIGHT ANGLE	
X.	±0.60	X.	±5°	UNITS	mm			
.X	±0.38	.X	±3°	SHEET SIZE	A4	SERIES	DS1026-12 SERIES	
.XX	±0.25	.XX	±2°	晨翔电子有限公司 CONNFLY CONNFLY ELECTRONIC CO. LTD				
DRAWING TYPE		CUSTOMER						
SCALE	1:1	SHEET	1 OF 1					
DRAWING NO.		C-DS1026-12-XXXXX						

REV.	DESCRIPTION	DRAWN	CHECKED	APPROVED
A	NEW RELEASE	LJC 09/06/08'	~	LJC 09/06/08'
B	整理图面	YCH 10/08/08'	~	LJC 10/08/08'
C	整理图面	YCH 11/01/08'	~	

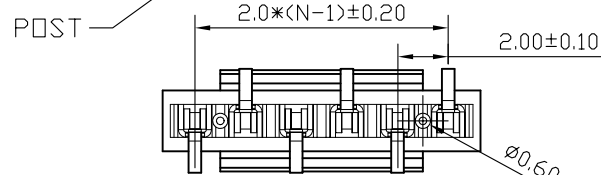
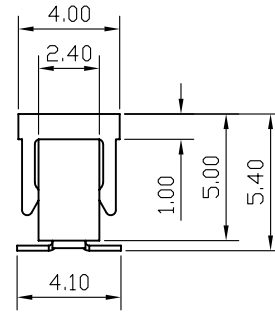
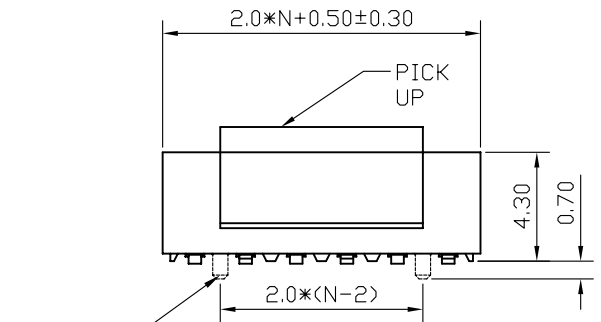
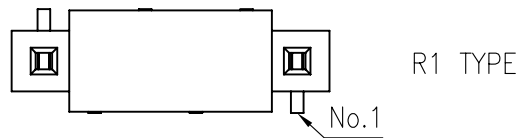
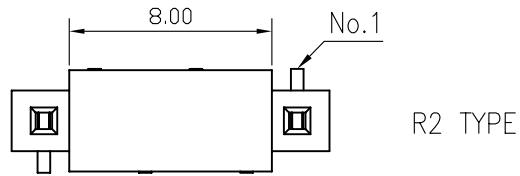

N:NUMBER OF CONTACTS

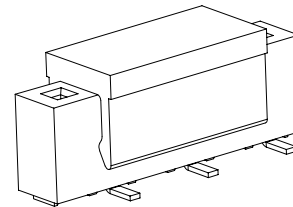

NOTES:

- ELECTRICAL CHARACTERISTICS:
 - CONTACT RESISTANCE: 20mΩ Max. INITIAL.
 - DIELECTRIC WITHSTANDING VOLTAGE: 500V AC(rms) FOR 1 MINUTE.
 - INSULATION RESISTANCE: 1000MΩ Min.
- ENVIRONMENT CHARACTERISTICS:
 - OPERATING TEMPERATURE: -40°C~+105°C.
- PART NUMBER: DS1026-03
- PRODUCT NUMBER CODE:

DS1026-03 - X X X X X X X

- POST SUPPORT
S:W/ POST
X:W/O POST
- PACKING TYPE
T:TRAY
R:TAPE ON REEL
B:TUBE
- PICK UP SUPPORT
S:W/ PICK UP
X:W/O PICK UP
- BEND TYPE
1: R1 TYPE
2: R2 TYPE
- HOUSING COLOR
B:BLACK
- CONTACT PLATING
8: FULL GOLD FLASH
- No.OF CONTACTS
1*1-1*40

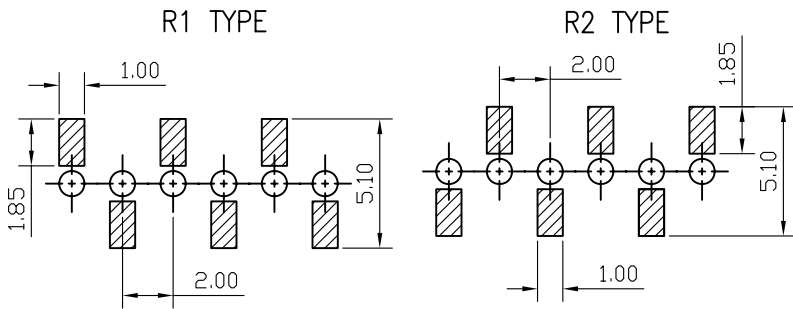

RECOMMEND PCB LAYOUT(TOLERANCE=±0.05)

GENERAL TOLERANCE		ANGLE TOLERANCE		PROJECTION		TITLE	2.0 Pitch Female Header Single Row SMT Type	
X.	±0.60	X.	±5'	UNITS	mm			
.X	±0.38	.X	±3'	SHEET SIZE	A4	SERIES	DS1026-03 SERIES	
.XX	±0.25	.XX	±2'	晨翔电子有限公司 CONNFLY CONNFLY ELECTRONIC CO. LTD				
DRAWING TYPE		CUSTOMER						
SCALE		1:1 SHEET 1 OF 1						
DRAWING NO.		C-DS1026-03-XXXXXX						

REV.	DESCRIPTION	DRAWN	CHECKED	APPROVED
A	NEW RELEASE	YCH 06/04/07'		

N=NUMBER OF CONTACTS

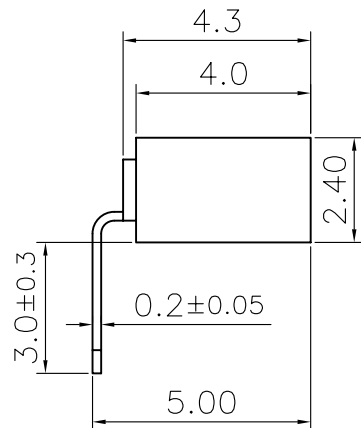
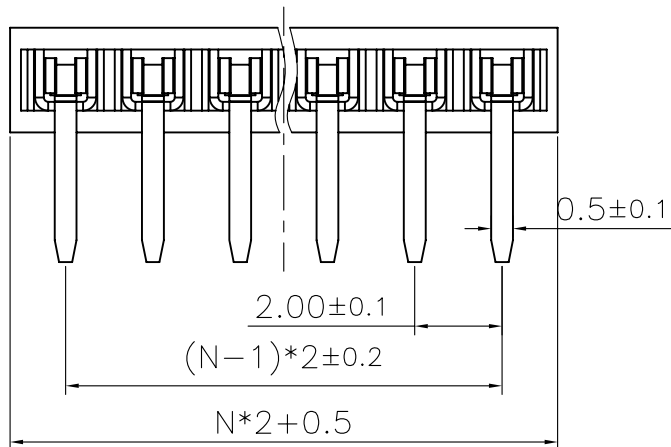

NOTES:

- ELECTRICAL CHARACTERISTICS:
 - CONTACT RESISTANCE: 20mΩ Max. INITIAL.
 - DIELECTRIC WITHSTANDING VOLTAGE: 500V AC(rms) FOR 1 MINUTE.
 - INSULATION RESISTANCE: 1000MΩ Min.
- ENVIRONMENT CHARACTERISTICS:
 - TEMPERATURE: -40°C~+105°C.
- PART NUMBER: DS1026-15
- PRODUCT NUMBER CODE:

DS1026-15 - X X X X X

- CONTACTS TYPE
R:RIGHT ANGLE
- HOUSING COLOR
B:BLACK
- CONTACT PLATING
8: FULL GOLD FLASH
- CONNECTOR TYPE
S:SOCKET
- No.OF CONTACTS
1*1-1*40
- SERIES No.
DS1026-15

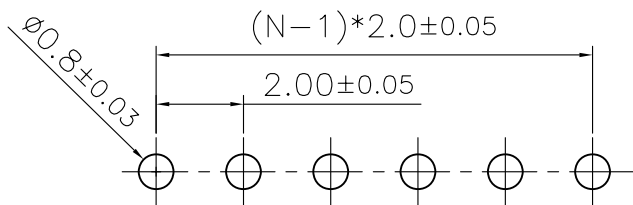
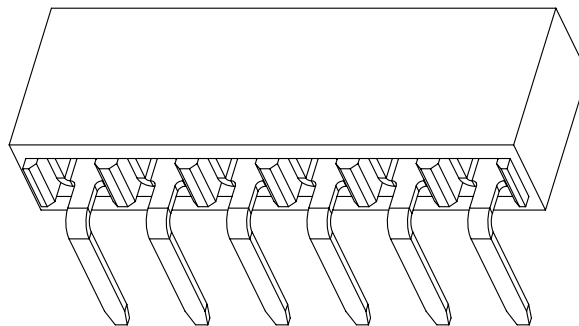
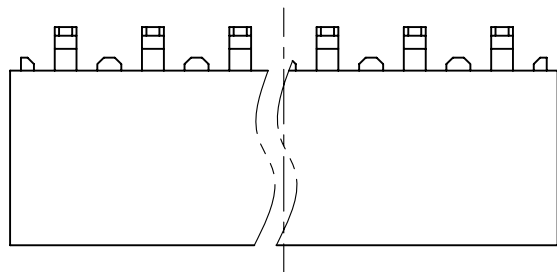

Recommend PCB layout

GENERAL TOLERANCE	ANGLE TOLERANCE
X. ±0.60	X. ±5°
.X ±0.38	.X ±3°
.XX ±0.25	.XX ±2°

PROJECTION	TITLE
UNITS mm	FEMALE HEADER PITCH 2.00mmTYPE
SHEET SIZE A4	SERIES DS1026-15 SERIES

DRAWING TYPE	CUSTOMRE
SCALE 1:1	SHEET 1 OF 1
DRAWING NO.	DS1026-15-XXXXX-A

晨翔电子有限公司
CONNFLY CONNFLY ELECTRONIC CO. LTD

REV.	DESCRIPTION	DRAWN	CHECKED	APPROVED
A	NEW RELEASE	LJH 06/22/05'		

N=NUMBER OF CONTACTS/2

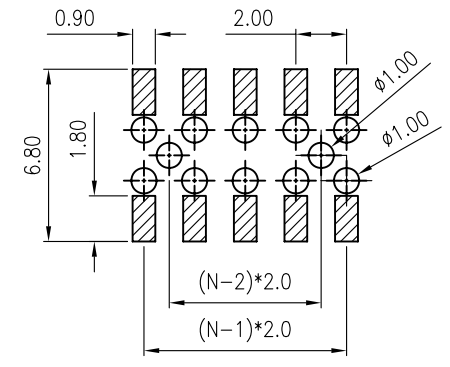
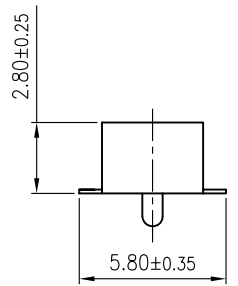
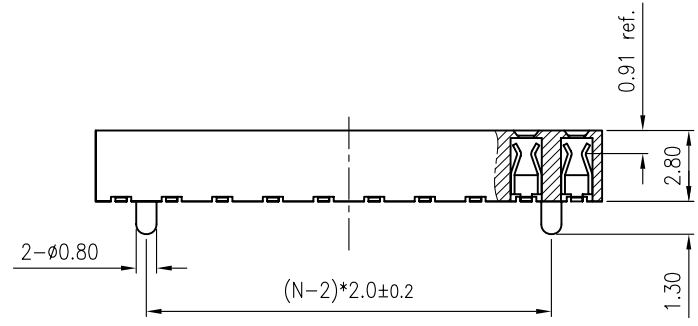
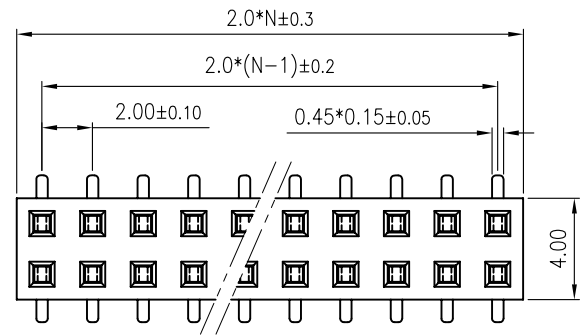

RECOMMEND PCB LAYOUT
(TOLERANCE=±0.05)

NOTES:

- ELECTRICAL CHARACTERISTICS:
 - CONTACT RESISTANCE: 20mΩ Max. INITIAL.
 - DIELECTRIC WITHSTANDING VOLTAGE: 500V AC(rms) FOR 1 MINUTE.
 - INSULATION RESISTANCE: 1000MΩ Min.
- ENVIRONMENT CHARACTERISTICS:
 - OPERATING TEMPERATURE: -40°C~+105°C.

3. PART NUMBER: DS1026-08

4. PRODUCT NUMBER CODE:

DS1026-08 - X X X X X

- CONTACTS TYPE
S:SMT
- HOUSING COLOR
B:BLACK
- CONTACT PLATING
8: FULL GOLD FLASH
- CONNECTOR TYPE
S:SOCKET
- No.OF CONTACTS
2*1-2*X
- SERIES No.
DS1026-08

GENERAL TOLERANCE		ANGLE TOLERANCE		PROJECTION		TITLE	DUAL ROW W/N LOCATE PEG S.M.T	
X.	±0.60	X.	±5°	UNITS	mm			
.X	±0.38	.X	±3°	SHEET SIZE	A4	SERIES	DS1026-08 SERIES	
.XX	±0.25	.XX	±2°	晨翔电子有限公司 CONNFLY CONNFLY ELECTRONIC CO. LTD				
DRAWING TYPE		CUSTOMER						
SCALE	1:1	SHEET	1 OF 1					
DRAWING NO.		C-DS1026-08-XXXXX						

REV.	DESCRIPTION	DRAWN	CHECKED	APPROVED
A	NEW RELEASE	YCH 07/27/10'	~	

N=HALF OF PIN POSITIONS

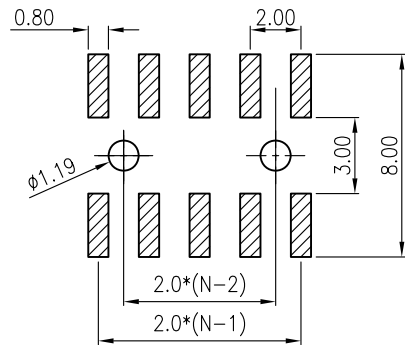
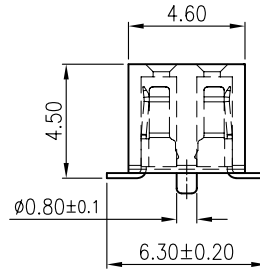
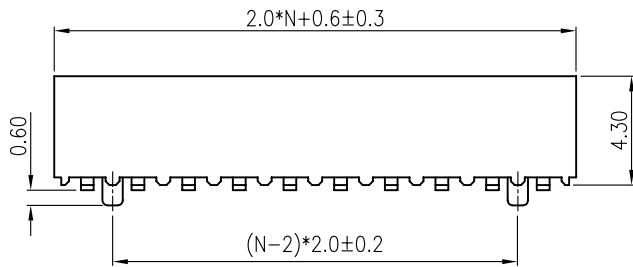
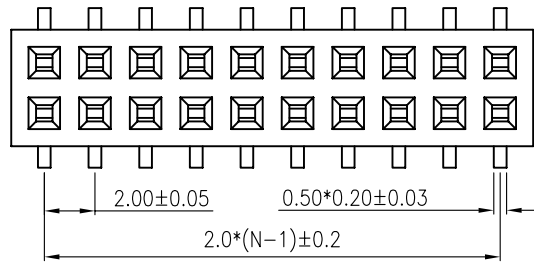

NOTES:

- ELECTRICAL CHARACTERISTICS:
 - CONTACT RESISTANCE: 20m Ω Max. INITIAL.
 - DIELECTRIC WITHSTANDING VOLTAGE: 500V AC(rms) FOR 1 MINUTE.
 - INSULATION RESISTANCE: 1000M Ω Min.
- ENVIRONMENT CHARACTERISTICS:
 - TEMPERATURE: $-40^{\circ}\text{C} \sim +105^{\circ}\text{C}$.
- PART NUMBER: DS1026-07
- PRODUCT NUMBER CODE:

DS1026-07 - X X X X X X

- POST SUPPORT
S:W/ POST
X:W/O POST
- CONTACTS TYPE
S:SMT
- HOUSING COLOR
B:BLACK
- CONTACT PLATING
8: FULL GOLD FLASH
- CONNECTOR TYPE
S:SOCKET
- No.OF CONTACTS
2*1-2*X
- SERIES No.
DS1026-07

GENERAL TOLERANCE		ANGLE TOLERANCE		PROJECTION		TITLE	DUAL ROW W/N LOCATE PEG S.M.T	
X.	± 0.60	X.	$\pm 5^{\circ}$	UNITS	mm			
.X	± 0.38	.X	$\pm 3^{\circ}$	SHEET SIZE	A4	SERIES	DS1026-07 SERIES	
.XX	± 0.25	.XX	$\pm 2^{\circ}$	晨翔电子有限公司 CONNFLY CONNFLY ELECTRONIC CO. LTD				
DRAWING TYPE		CUSTOMER						
SCALE	1:1	SHEET	1 OF 1					
DRAWING NO.		C-DS1026-07-2*XXXXX						

REV.	DESCRIPTION	DRAWN	CHECKED	APPROVED
A	NEW RELEASE	LJH 06/22/05'		

N: NUMBER OF CONTACTS/2
H/B: CUSTOMER LENGTH AVAILABLE

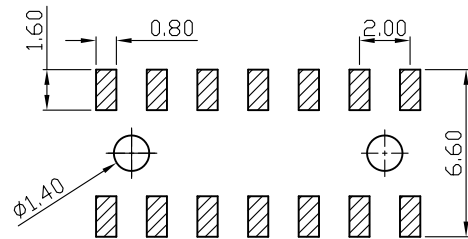
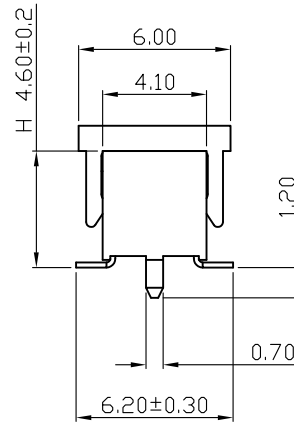
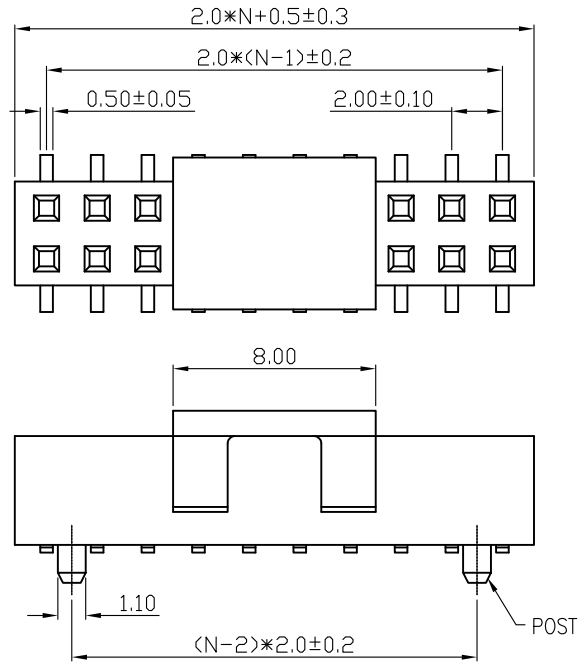

RECOMMEND PCB LAYOUT
(TOLERANCE=±0.05)

NOTES:

- ELECTRICAL CHARACTERISTICS:
 - CONTACT RESISTANCE: 20mΩ Max. INITIAL.
 - DIELECTRIC WITHSTANDING VOLTAGE: 500V AC(rms) FOR 1 MINUTE.
 - INSULATION RESISTANCE: 1000MΩ Min.
- ENVIRONMENT CHARACTERISTICS:
 - TEMPERATURE: -40°C~+105°C.
- PART NUMBER: DS1026-09
- PRODUCT NUMBER CODE:
DS1026-09 - X X X X X X X X

- POST SUPPORT
S:W/ POST
X:W/O POST
- PACKING TYPE
T:TRAY
R:TAPE ON REEL
B:TUBE
- PICK UP SUPPORT
S:W/ PICK UP
X:W/O PICK UP
- CONTACTS TYPE
S:SMT
- HOUSING COLOR
B:BLACK
- CONTACT PLATING
8:FULL GOLD FLASH
- CONNECTOR TYPE
S:SOCKET
- No.OF CONTACTS
2*1-2*X

GENERAL TOLERANCE		ANGLE TOLERANCE		PROJECTION		TITLE	DUAL ROW W/N LOCATE PEG S.M.T	
X.	±0.60	X.	±5'	UNITS	mm			
.X	±0.38	.X	±3'	SHEET SIZE	A4	SERIES	DS1026-09 SERIES	
.XX	±0.25	.XX	±2'	晨翔电子有限公司 CONNFLY CONNFLY ELECTRONIC CO. LTD				
DRAWING TYPE		CUSTOMER						
SCALE	1:1	SHEET	1 OF 1					
DRAWING NO.		C-DS1026-09-XXXXXXX						

REV.	DESCRIPTION	DRAWN	CHECKED	APPROVED
A	NEW RELEASE	LJC 12/15/09'		

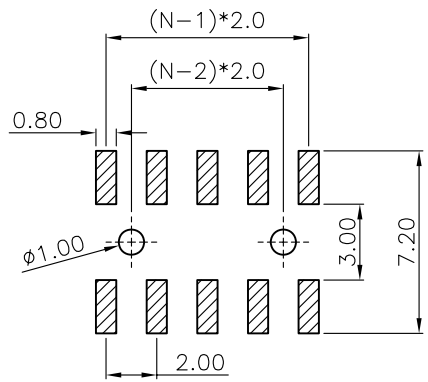
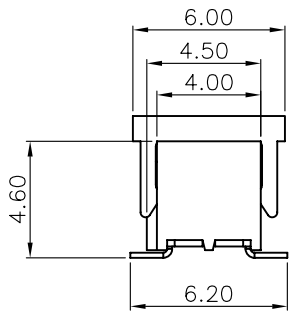
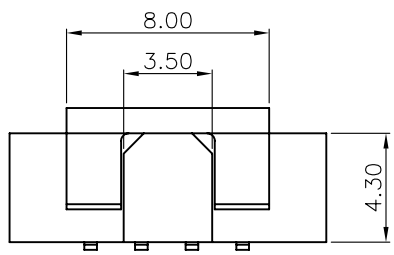
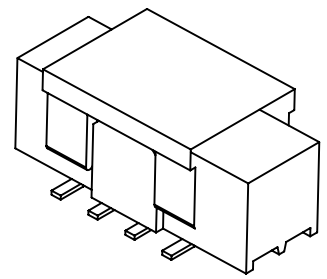
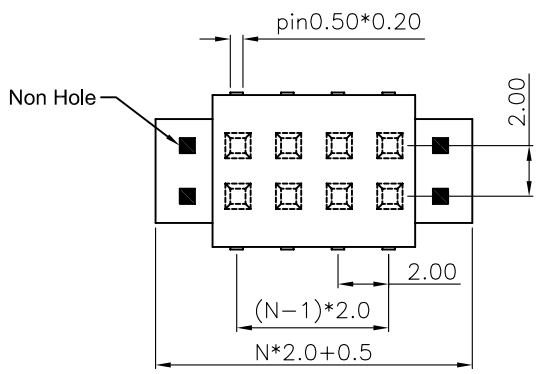

RECOMMEND PCB LAYOUT(TOLERANCE=±0.05)

NOTES:

- MATERIALS:
 - INSULATOR: HIGH TEMPERATURE PA-46 W/ GLASS FIBER DSM MODLE TYPE TE250F6
 - CONTACT: PHOSPHOR BRONZE.PLATING FULL GOLD.
- ELECTRICAL CHARACTERISTICS:
 - CONTACT RESISTANCE: 20mΩ Max. INITIAL.
 - DIELECTRIC WITHSTANDING VOLTAGE: 500V AC(rms) FOR 1 MINUTE.
 - INSULATION RESISTANCE: 1000MΩ Min.
- ENVIRONMENT CHARACTERISTICS:
 - TEMPERATURE: -40°C~+105°C.
 - RESISTANCE TO SOLDERING HEAT: 260±5°C,5-10s.
- PRODUCT NUMBER CODE:

DS1026-16 - X X X X X X

 - POST SUPPORT
S:W/ POST
X:W/O POST
 - PACKING TYPE
T:TRAY
R:TAPE ON REEL
B:TUBE
 - PICK UP SUPPORT
S:W/ PICK UP
X:W/O PICK UP
 - POLOARIZATION SUPPORT
S: W/ POLOARIZATION
X: W/O POLOARIZATION
 - CONTACT PLATING
8: FULL GOLD FLASH
 - HOUSING COLOR
B:BLACK
 - No.OF CONTACTS(W/ contacts)
2*4-2*32

GENERAL TOLERANCE		ANGLE TOLERANCE		PROJECTION		TITLE	2.0mm Female Header W/ Polarization Match To 2.0 Box Header SMT type
X.	±0.60	X.	±5°	UNITS	mm	SHEET SIZE	A4
.X	±0.38	.X	±3°				
.XX	±0.25	.XX	±2°				
DRAWING TYPE		CUSTOMER		晨翔电子有限公司 CONNFLY CONNFLY ELECTRONIC CO. LTD			
SCALE	1:1	SHEET	1 OF 1				
DRAWING NO.	C-DS1026-16-XXXXXXX						

REV.	DESCRIPTION	DRAWN	CHECKED	APPROVED
A	NEW RELEASE	LJH 06/22/05'		

N: NUMBER OF CONTACTS/2

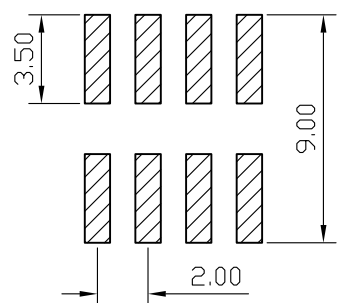
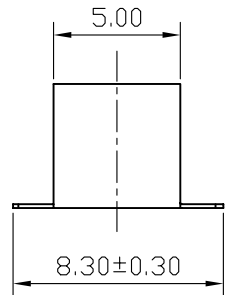
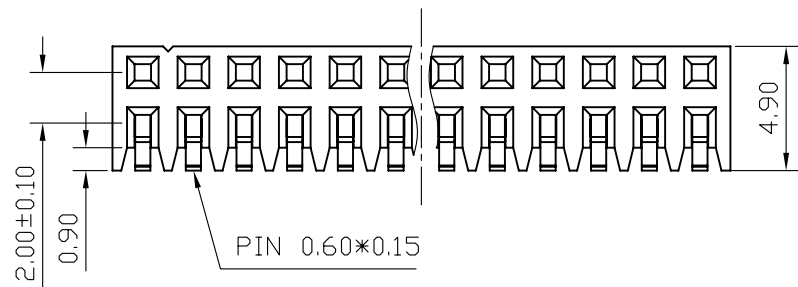
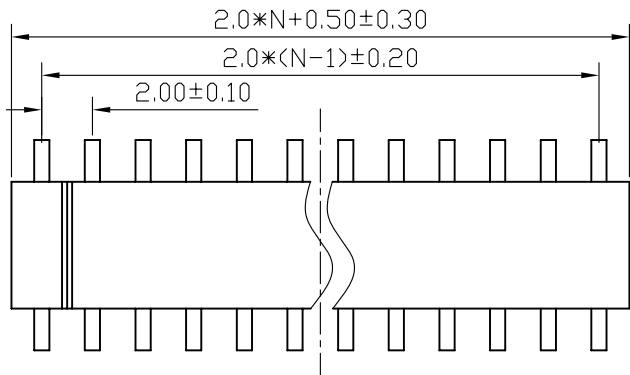

RECOMMAND PCB LAYOUT
(TOLERANCE=±0.05)

NOTES:

- ELECTRICAL CHARACTERISTICS:
 - CONTACT RESISTANCE: 20mΩ Max. INITIAL.
 - DIELECTRIC WITHSTANDING VOLTAGE: 500V AC(rms) FOR 1 MINUTE.
 - INSULATION RESISTANCE: 1000MΩ Min.
- ENVIRONMENT CHARACTERISTICS:
 - TEMPERATURE: -40°C~+105°C.
- PART NUMBER: DS1026-14
- PRODUCT NUMBER CODE:

DS1026-14 - X X X X X

- CONTACTS TYPE
S:SMT
- HOUSING COLOR
B:BLACK
- CONTACT PLATING
8: FULL GOLD FLASH
- CONNECTOR TYPE
S:SOCKET
- No.OF CONTACTS
2*1-2*X
- SERIES No.
DS1026-14

GENERAL TOLERANCE		ANGLE TOLERANCE		PROJECTION		TITLE	SIDE ENTRY S.M.T	
X.	±0.60	X.	±5°	UNITS	mm			
.X	±0.38	.X	±3°	SHEET SIZE	A4	SERIES	DS1026-14 SERIES	
.XX	±0.25	.XX	±2°	晨翔电子有限公司 CONNFLY CONNFLY ELECTRONIC CO. LTD				
DRAWING TYPE		CUSTOMER						
SCALE	1:1	SHEET	1 OF 1					
DRAWING NO.		C-DS1026-14-XXXXX						

REV.	DESCRIPTION	DRAWN	CHECKED	APPROVED
A	NEW RELEASE	LJH 06/22/05'		

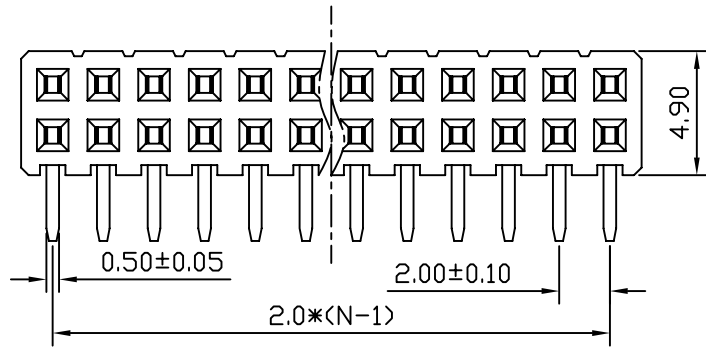
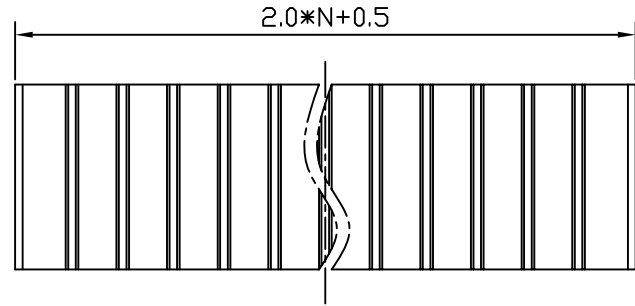

N: HALF OF PIN POSITIONS

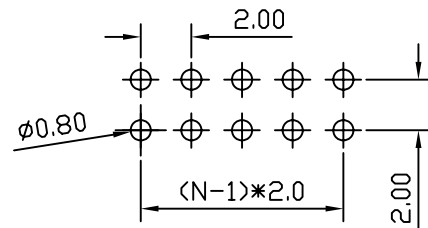
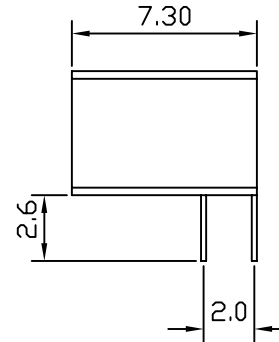

RECOMMEND PCB LAYOUT
(TOLERANCE=±0.05)

NOTES:

- ELECTRICAL CHARACTERISTICS:
 - CONTACT RESISTANCE: 20mΩ Max. INITIAL.
 - DIELECTRIC WITHSTANDING VOLTAGE: 500V AC(rms) FOR 1 MINUTE.
 - INSULATION RESISTANCE: 1000MΩ Min.
- ENVIRONMENT CHARACTERISTICS:
 - EMPERATURE: -40°C~+105°C.
- PART NUMBER: DS1026-13
- PRODUCT NUMBER CODE:
DS1026-13 - X X X X X

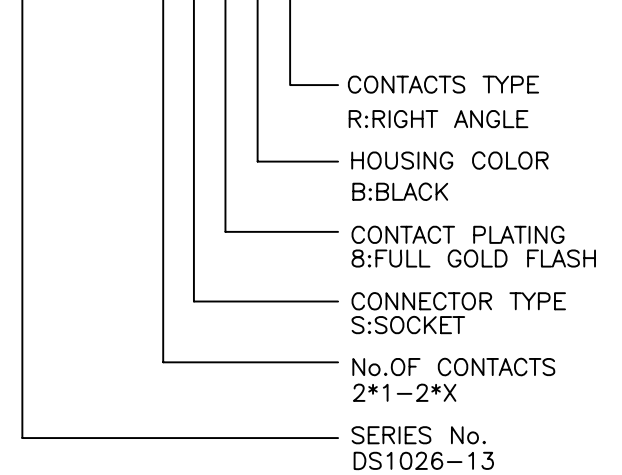

GENERAL TOLERANCE		ANGLE TOLERANCE		PROJECTION		TITLE	SIDE ENTRY RIGHT ANGLE	
X.	±0.60	X.	±5'	UNITS	mm			
.X	±0.38	.X	±3'	SHEET SIZE	A4	SERIES	DS1026-13 SERIES	
.XX	±0.25	.XX	±2'	晨翔电子有限公司 CONNFLY CONNFLY ELECTRONIC CO. LTD				
DRAWING TYPE		CUSTOMER						
SCALE	1:1	SHEET	1 OF 1					
DRAWING NO.		C-DS1026-13-XXXXX						