

REV.	DESCRIPTION	DRAWN	CHECKED	APPROVED
A	NEW RELEASE	YCH 05/10/12'	~	

NOTES:

- MATERIAL
  - INSULATOR:THERMOPLASTIC(UL 94V-0).
  - CONTACT MATERIAL:COPPER ALLOY.
- SPECIFICATION
  - CURRENT RATING:1.0 Amp.
  - INSULATION RESISTANCE:500MΩ Min.
  - DIELECTRIC WITHSTANDING:600VAC.
  - CONTACT RESISTANCE:20mΩ Max.
  - OPERATING TEMPERATURE:-45°C TO+110°C.

3. PART NUMBER: DS1031-33

4. PRODUCT NUMBER CODE:

DS1031-33 - X X X X X X X X

- PACKING TYPE
- T: TRAY
- R: TAPE ON REEL
- B: TUBE
- PICK UP SUPPORT
- S: W/ PICK UP
- X: W/O PICK UP
- BEND TYPE
- A: R1 TYPE
- B: R2 TYPE
- DIM.A B TYPE
- 1: TYPE 1
- MOUNTING TYPE
- S: SMT TYPE
- HOUSING COLOR
- B:BLACK
- CONTACT PLATING
- 8: FULL GOLD FLASH
- CONNECTOR TYPE
- P:PLUG
- No.OF CONTACTS
- 1\*3-1\*50

TYPE	DIM A	DIM B	DIM C
1	3.20	2.80	6.50
2			
3			
4			
5			
6			
7			
8			

R2 TYPE

R1 TYPE

GENERAL TOLERANCE		ANGLE TOLERANCE	
X.	±0.60	X.	±5°
.X	±0.38	.X	±3°
.XX	±0.25	.XX	±2°

PROJECTION	TITLE	SINGLE ROW PIN HEADER	
mm		PITCH 1.0mm SMT TYPE	
SHEET SIZE	A4	SERIES	DS1031-33 SERIES

DRAWING TYPE	CUSTOMER		
SCALE	1:1	SHEET	1 OF 1
DRAWING NO.	C-DS1031-33-XXXXXXXX		

 晨翔电子有限公司  
CONNFLY CONNFLY ELECTRONIC CO. LTD

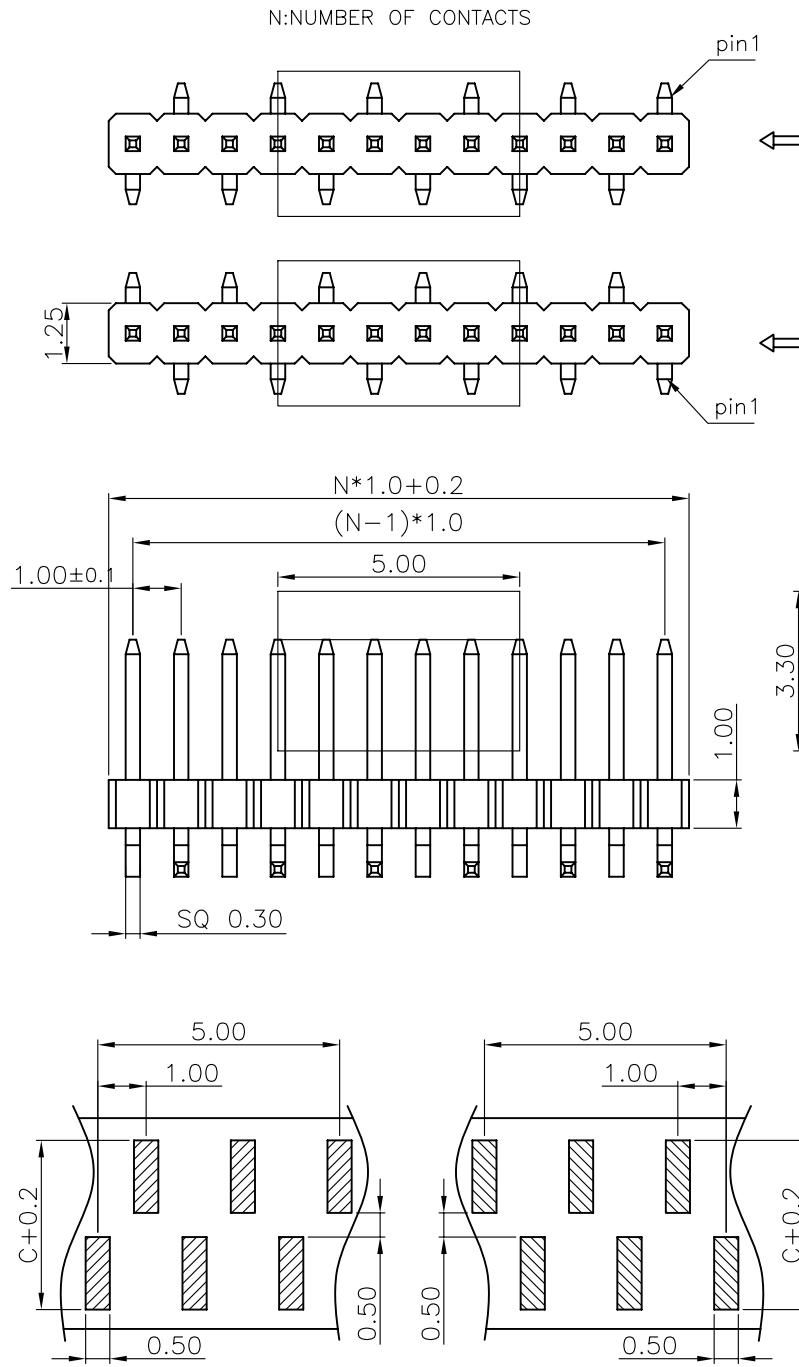

RECOMMEND PCB LAYOUT(R2 TYPE) (TOLERANCE=±0.05)      RECOMMEND PCB LAYOUT(R1 TYPE) (TOLERANCE=±0.05)

REV.	DESCRIPTION	DRAWN	CHECKED	APPROVED
A	NEW RELEASE	YCH 05/10/12'	~	

NOTES:

- MATERIAL
  - INSULATOR:THERMOPLASTIC(UL 94V-0).
  - CONTACT MATERIAL:COPPER ALLOY.
- SPECIFICATION
  - CURRENT RATING:1.0 Amp.
  - INSULATION RESISTANCE:500MΩ Min.
  - DIELECTRIC WITHSTANDING:600VAC.
  - CONTACT RESISTANCE:20mΩ Max.
  - OPERATING TEMPERATURE:-45°C TO+110°C.
- PART NUMBER: DS1031-34
- PRODUCT NUMBER CODE:

DS1031-34 - X X X X X X X X

- PACKING TYPE  
T: TRAY  
R: TAPE ON REEL  
B: TUBE
- PICK UP SUPPORT  
S: W/ PICK UP  
X: W/O PICK UP
- BEND TYPE  
A: R1 TYPE  
B: R2 TYPE
- DIM.A B TYPE  
1: TYPE 1
- MOUNTING TYPE  
S: SMT TYPE
- HOUSING COLOR  
B:BLACK
- CONTACT PLATING  
8: FULL GOLD FLASH
- CONNECTOR TYPE  
P:PLUG
- No.OF CONTACTS  
1\*3-1\*50

TYPE	DIM A	DIM B	DIM C
1	7.00	6.50	7.80
2			
3			
4			
5			
6			
7			
8			

GENERAL TOLERANCE		ANGLE TOLERANCE	
X.	±0.60	X.	±5°
.X	±0.38	.X	±3°
.XX	±0.25	.XX	±2°

PROJECTION	TITLE	SINGLE ROW DULE HOUSING	
mm		PIN HEADER PITCH 1.0mm SMT TYPE	
A4	SERIES	DS1031-34 SERIES	

DRAWING TYPE	CUSTOMER		
SCALE	1:1	SHEET	1 OF 1
DRAWING NO.	C-DS1031-34-XXXXXXXX		

 晨翔电子有限公司  
**CONNFLY CONNFLY ELECTRONIC CO. LTD**

N:NUMBER OF CONTACTS

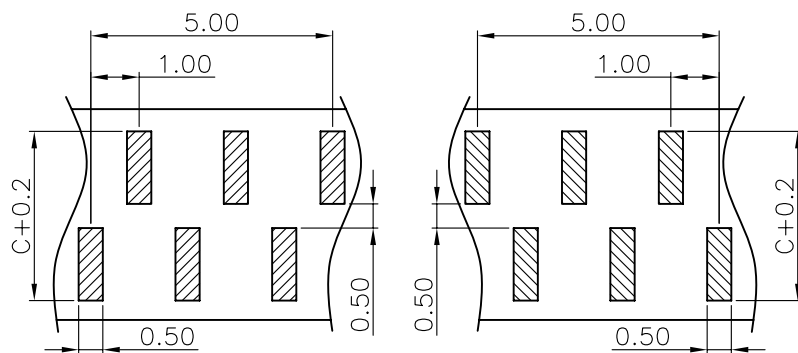
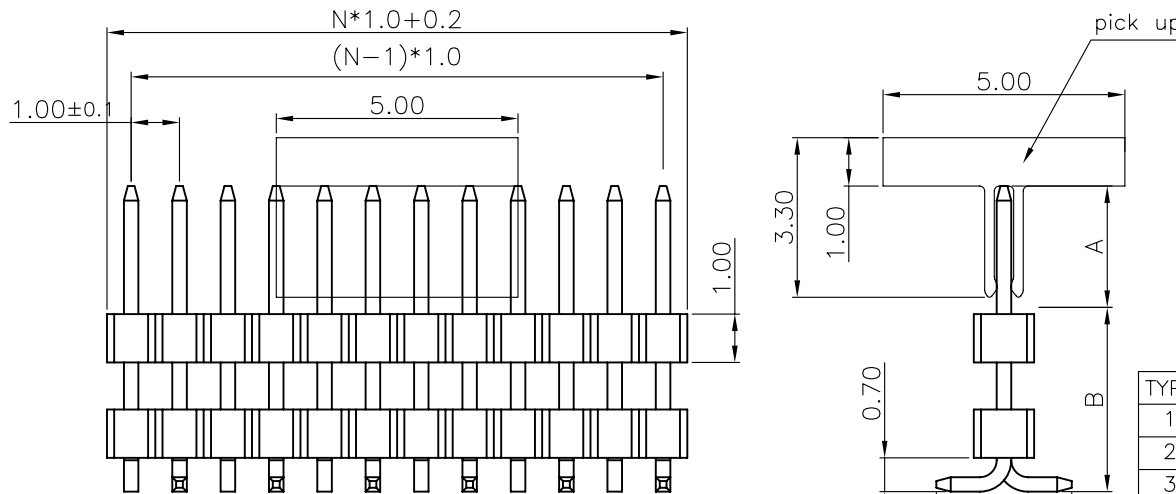
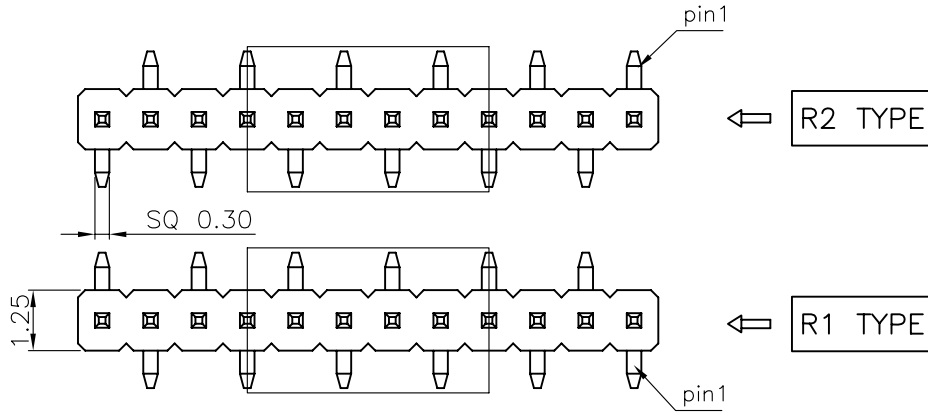

RECOMMEND PCB LAYOUT(R2 TYPE)  
(TOLERANCE=±0.05)

RECOMMEND PCB LAYOUT(R1 TYPE)  
(TOLERANCE=±0.05)